

# *TECHNICAL INFORMATION*

## **CITIZEN QUARTZ**

**Cal. No. 6800✳**

**Cal. No. 6850✳**

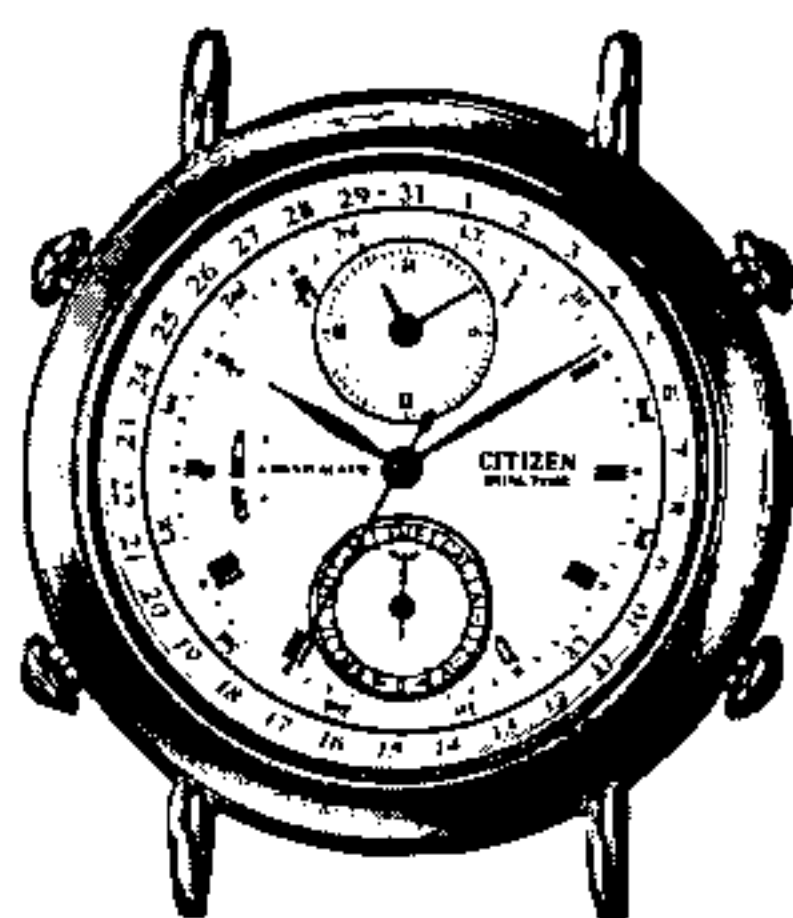

[Cal. No. 6800]



[Cal. No. 6850]

 **CITIZEN**  
CITIZEN IS A REGISTERED TRADEMARK OF CITIZEN WATCH CO., JAPAN.

---

## 1 OUTLINE

- **CAL 6800**

This analog multi-function quartz watch has eight modes each of which can be with the push button.

**Main functions**

- Calendar: Recognition of leap year, month, date
- Quick set alarm: Can be easily set from current time to a desired time. Alarm setting is automatically reset after sounding is completed.
- Daily alarm: Alarm sounds at a fixed time every day.
- Timer: 24 hours maximum. With fly-back function.
- Local time: Dual time function for setting another time, which is useful when traveling abroad on business.
- Local time alarm: Alarm sounds at a fixed local time every day.

- **CAL 6850**

This analog multi-function quartz watch has eight modes each of which can be with the push button.

**Main functions**

- Calendar: Month, date
- Quick set alarm: Can be easily set from current time to a desired time. Alarm setting is automatically reset after sounding is completed.
- Daily alarm: Alarm sounds at a fixed time every day.
- Stopwatch: Can be measured up to 60 minutes.
- Timer: 60 minutes maximum. With fly-back function.
- Local time: Dual time function for setting another time, which is useful when traveling abroad on business.

## 2 SPECIFICATIONS

Caliber No.	Cal. 6800
Type	Analog quartz multi-hand
Oscillation	32,768 Hz (Hz: Frequency in 1 sec)
Accuracy	±20 sec at normal temperature (5°C – 35°C)
Effective temperature range	-10°C – +60°C (14°F – 140°F)
Converter	Bipolar step motor
Integrated circuit	C-MOS-LSI (1 unit)
Adjustment of time rate	D.F.C. (No adjustment terminals)
Additional functions	<ul style="list-style-type: none"> <li>● Hand-type calendar Year (Recognition of leap year), month, date, no need of adjustment at end of month in leap year.</li> <li>● Alarm 1 (Quick set alarm) Maximum setting range: Up to 23 hours 59 minutes by 1 minute after the next minute at current time.</li> <li>● Alarm 2 (Daily alarm)</li> <li>● Timer Maximum setting range: 24 hours by 1 minute.</li> <li>● Local time Hour and minute (Set by 30 minutes. Second cannot be adjusted.)</li> </ul> <p>Other functions</p> <ul style="list-style-type: none"> <li>● Calendar monitor</li> <li>● Daily alarm set time monitor</li> <li>● Local time alarm set time monitor</li> </ul>
Power cell	Small-sized silver battery 1 piece. Power cell No.: 280-44 (SR927W)
Lifetime of power cell	Approx. 2 years Condition: Total alarm using time: 40 sec/day (Alarm 1: 10 sec) (Alarm 2: 15 sec) (Local time alarm: 15 sec) Timer: 1 time/day

Caliber No.	Cal. 6850
Type	Analog quartz multi-hand
Oscillation	32,768 Hz (Hz: Frequency in 1 sec)
Accuracy	±20 sec at normal temperature (5°C – 35°C)
Effective temperature range	-10°C – +60°C (14°F – 140°F)
Converter	Bipolar step motor
Integrated circuit	C-MOS-LSI (1 unit)
Adjustment of time rate	D.F.C. (No adjustment terminals)
Additional functions	<ul style="list-style-type: none"> <li>● Hand-type calendar Month, date, no need of adjustment at end of month.</li> <li>● Alarm 1 (Quick set alarm) Maximum setting range: Up to 23 hours 59 minutes by 1 minute after the next minute at current time.</li> <li>● Alarm 2 (Daily alarm)</li> <li>● Stopwatch Minute, second, 1/20 second (Maximum measuring range: 60 minutes.) Measurement of split time.</li> <li>● Timer Maximum setting range: 60 minutes by 1 minute.</li> <li>● Local time Hour and minute (Set by 30 minutes. Second cannot be adjusted.)</li> </ul> <p>Other functions</p> <ul style="list-style-type: none"> <li>● Calendar monitor</li> <li>● Daily alarm set time monitor</li> <li>● Zero second return function</li> </ul>
Power cell	Small-sized silver battery 1 piece. Power cell No.: 280-44 (SR927W)
Lifetime of power cell	Approx.: 2 years Condition: Total alarm using time: 25 sec/day (Alarm 1: 10 sec) (Alarm 2: 15 sec) Timer: 1 time/day Chronograph: 60 minutes/day

### 3-1 OPERATING METHOD CAL 6800

#### §1 MAIN COMPONENTS

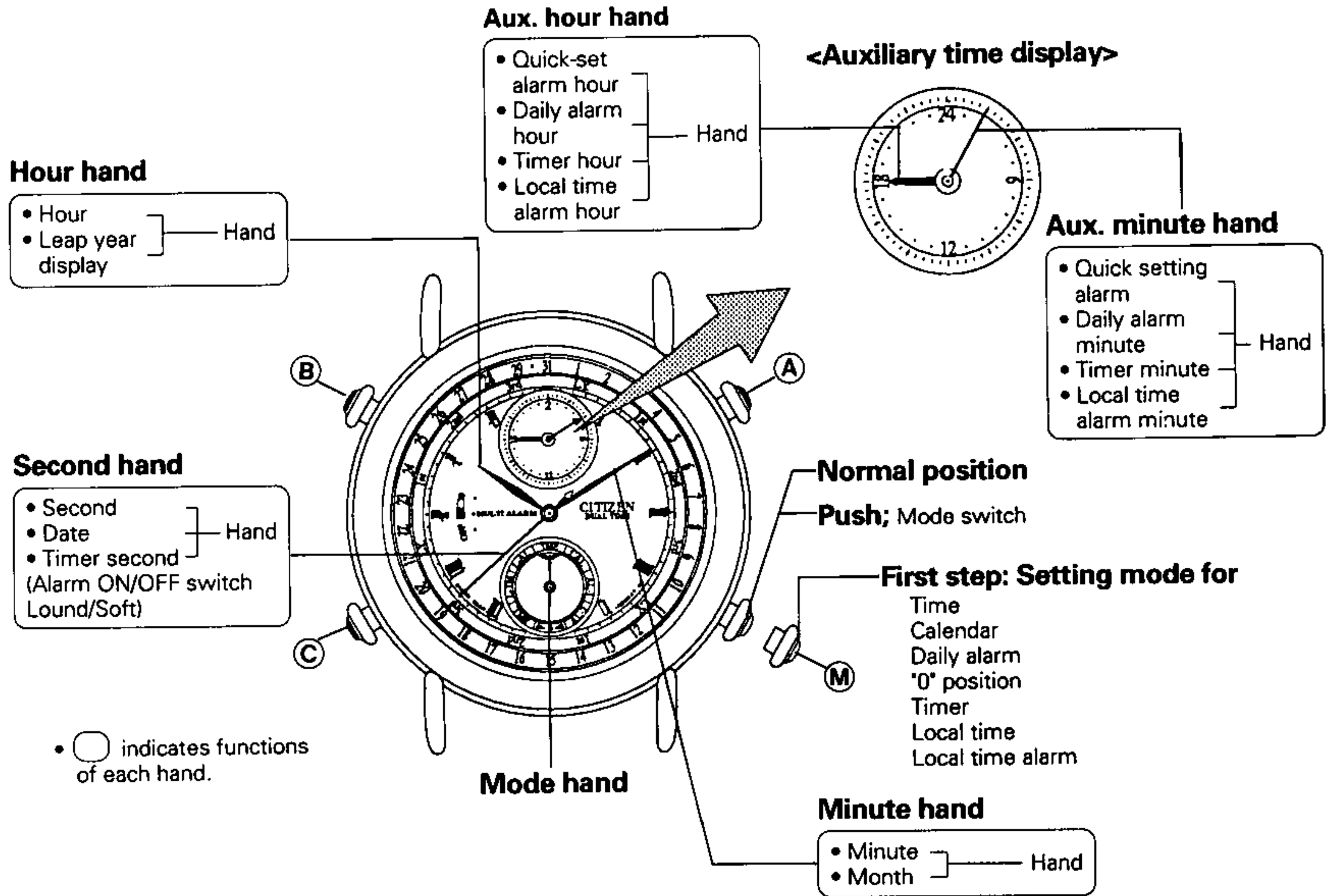

#### §2 MODE CHANGE-OVER

Push the (M) button in the normal position to switch between modes as shown below.

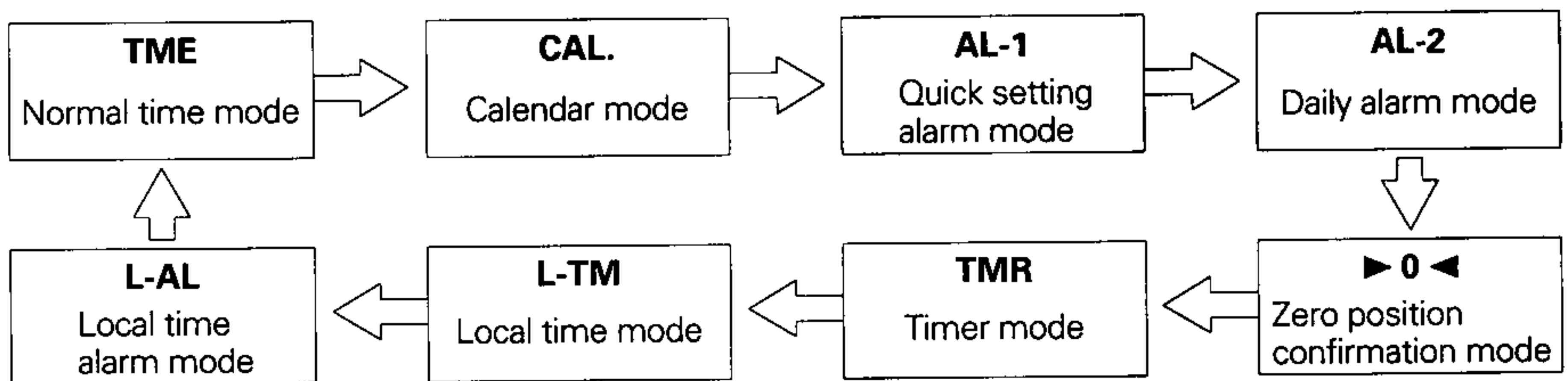

**Note:**

Check the mode hand to ensure the watch is set in the desired mode during use, since pressing the (M) button unconsciously during operation may occur.

### §3 BEFORE USE

Before use, follow the procedure below to ensure that all watch components are in proper working order: Confirm the Zero position setting.

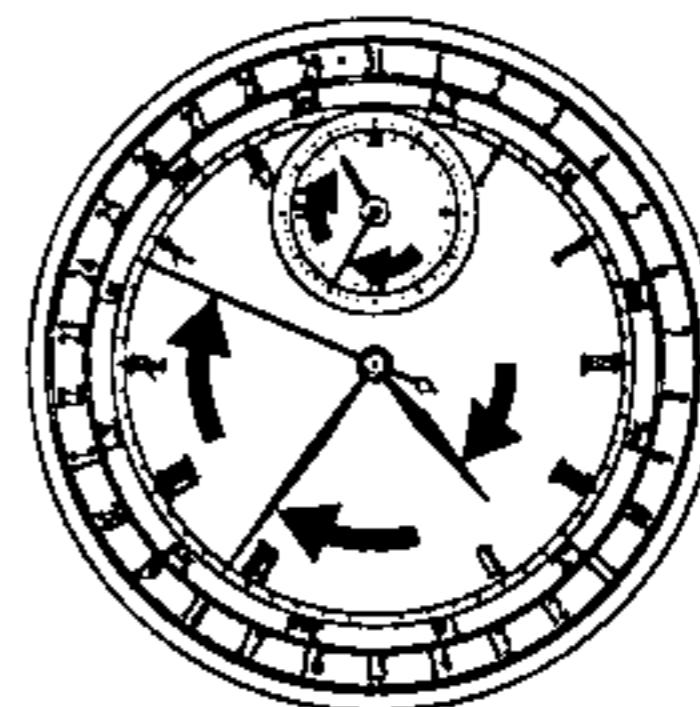
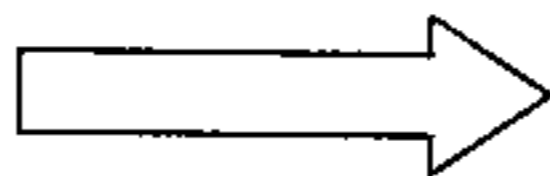
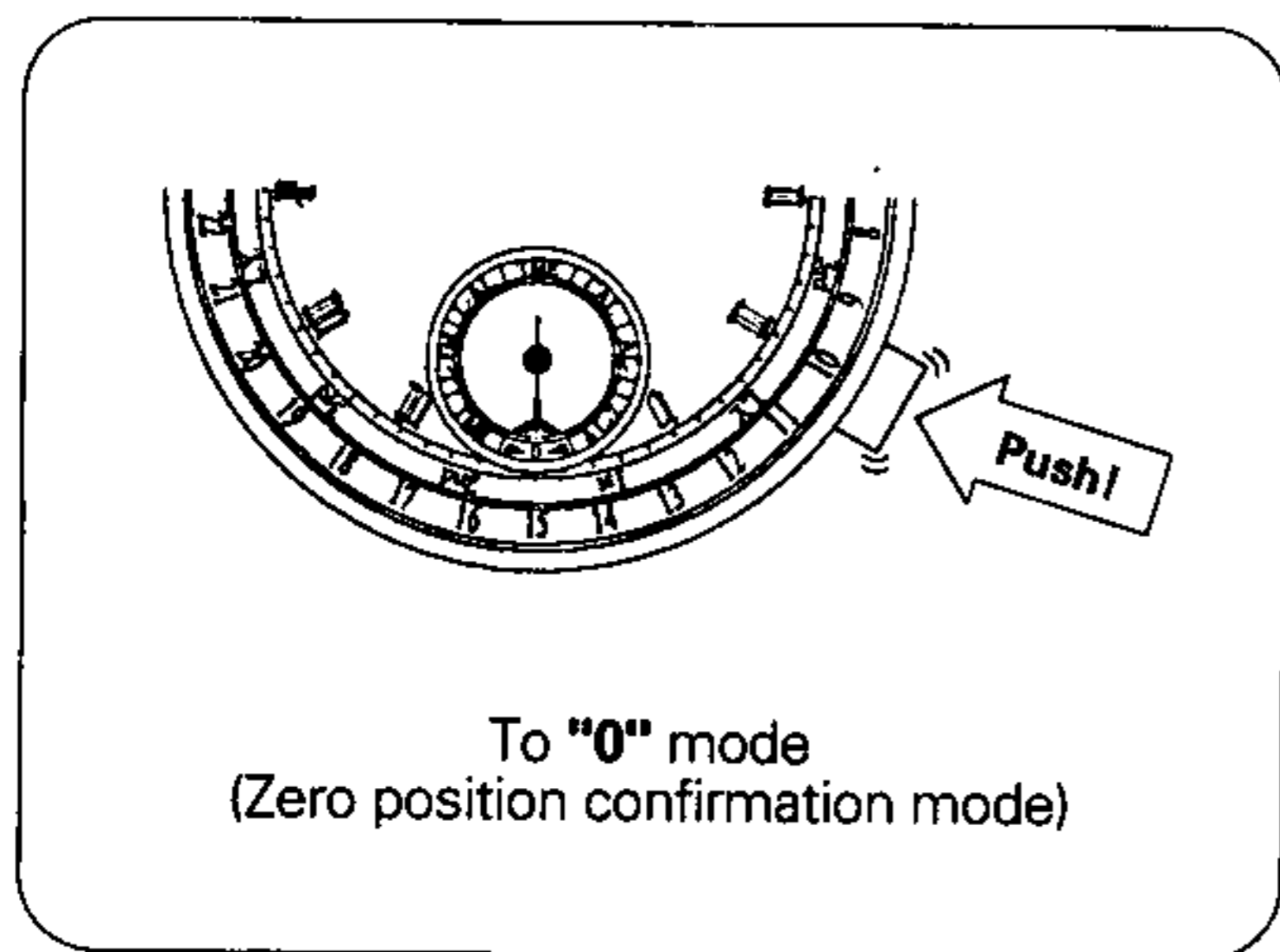

All hands, except the mode hand, move to the "0" position.

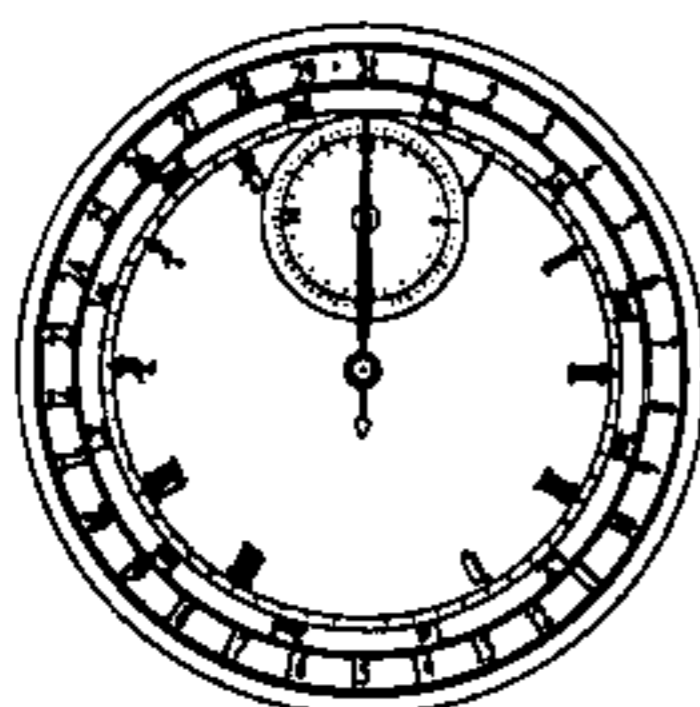
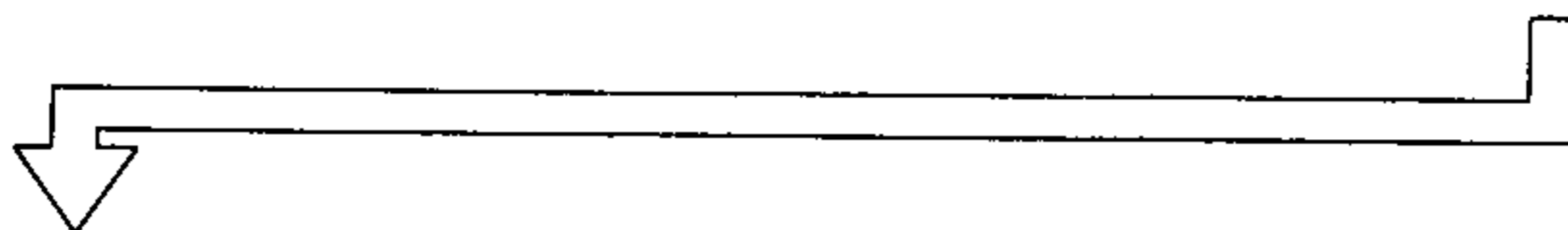

Each hand positioned as listed below confirms the Zero position setting correct.

<b>Hour hand</b> .....	0 hr.	} <b>position</b>
<b>Minute hand</b> .....	0 min.	
<b>Second hand</b> .....	00 sec.	
<b>Aux. hour hand</b> .....	0 hr.	
<b>Aux. minute hand</b> .....	0 min.	

If the watch hands are not positioned as above, follow the **Zero position setting** procedures to ensure proper use.

### ZERO POSITION SETTING

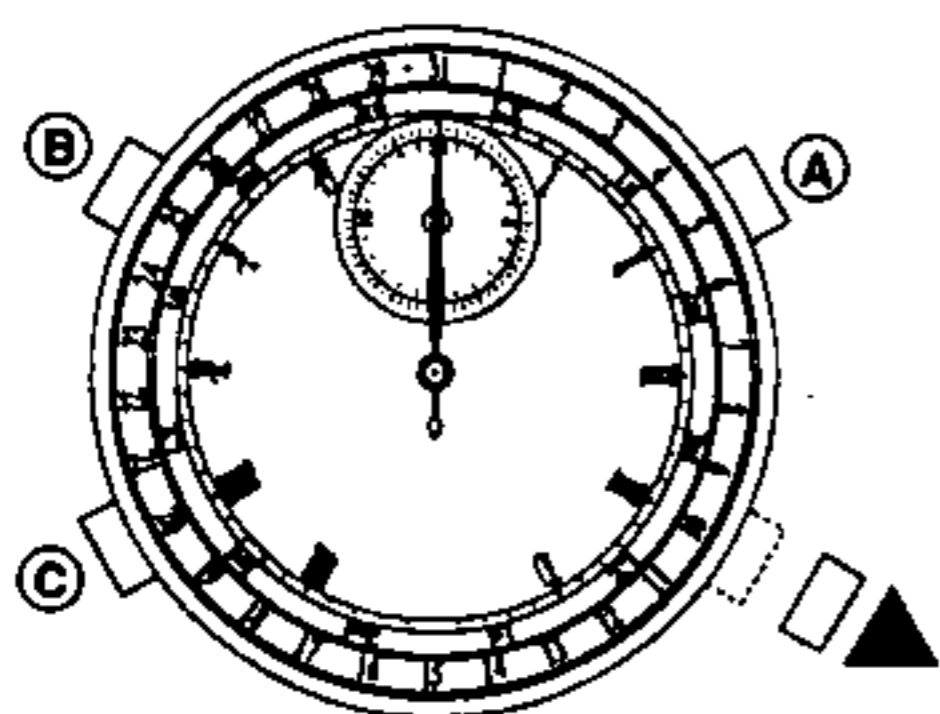

- 1) Pull the (M) button out to the first step  
 Push the (A) button to set the second hand to the 0 sec position.  
 Push the (B) button to set the Aux. hour/minute hands to the 0 hr./0 min. position.  
 Push the (C) button to set the hour/minute hands to the 0 hr./0 min. position.
  - 2) Push the (M) button in to the normal position to complete the setting procedure.
- ☆ Press and hold down either of the (A), (B), (C) button for the quick-advance feature.
  - ☆ A strong shock may cause the zero position to shift. In this case, reset to the correct zero position.



## §4 HOW TO SET AND OPERATE EACH MODE

### 1. HAND MOVEMENT DEMONSTRATION

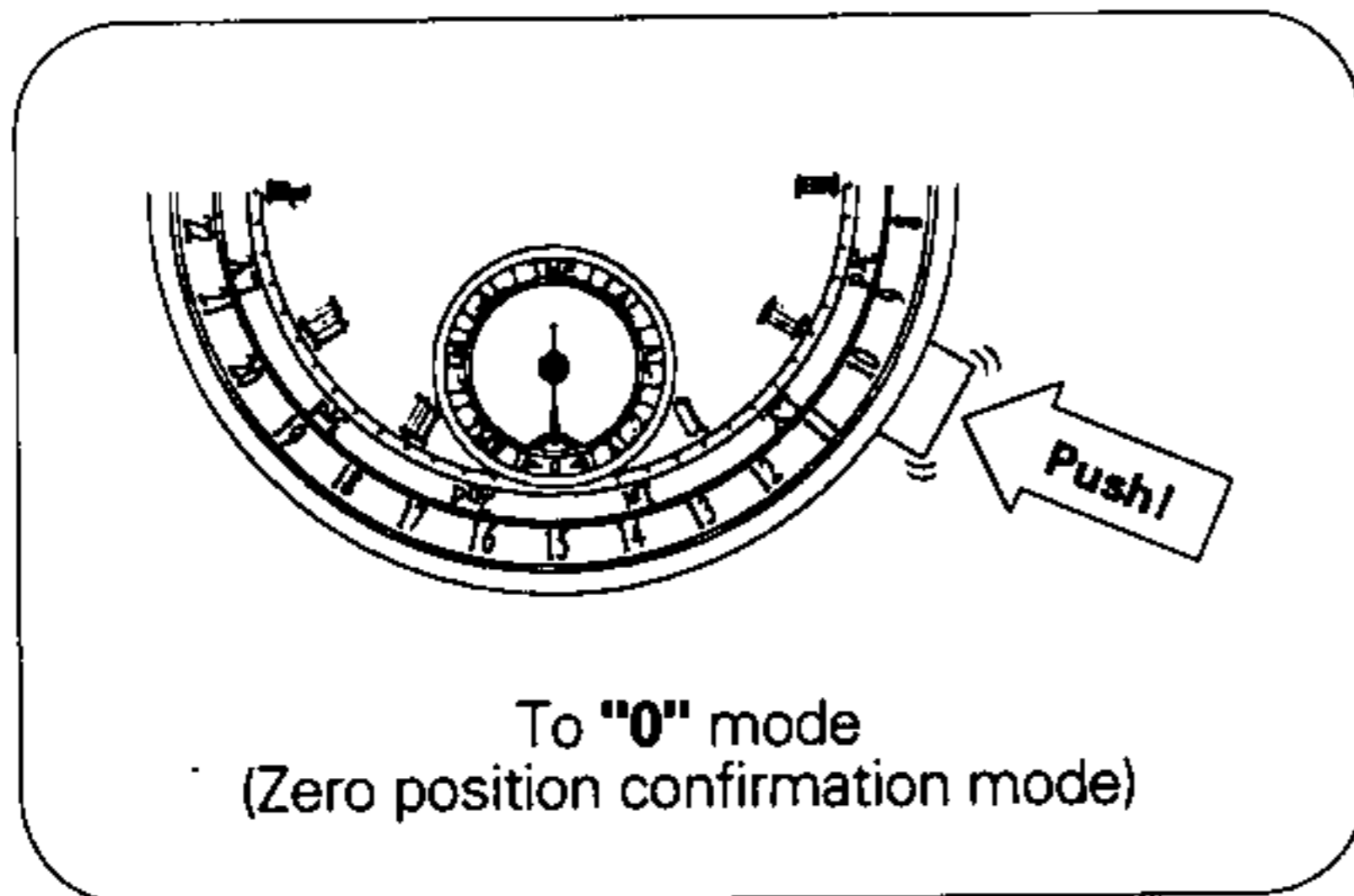

The (A), (B) and (C) buttons when each pushed once will cause the second, minute and auxiliary minute hands to stop in the "0" position after moving through the following stages.

- **Second hand:** ① +5 sec. → ② -10 sec. → ③ +5 sec.
- **Minute hand:** ① +5 min. → ② -10 min. → ③ +5 min.
- **Aux. minute hand:** ① +5 min. → ② -10 min. → ③ +5 min.

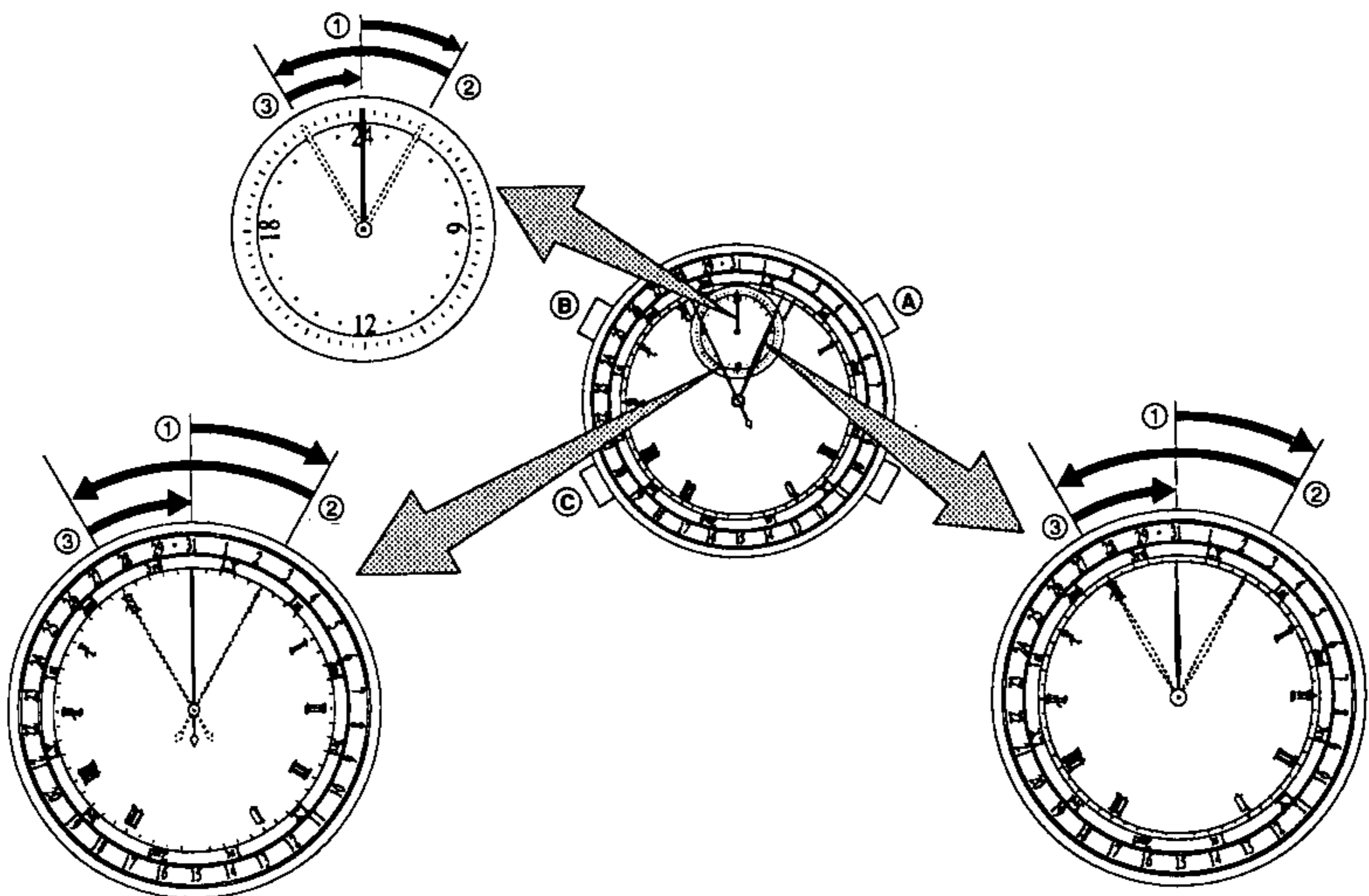

## 2. SETTING THE TIME

Setting the hands from 10:10'15" to 19:20'00".

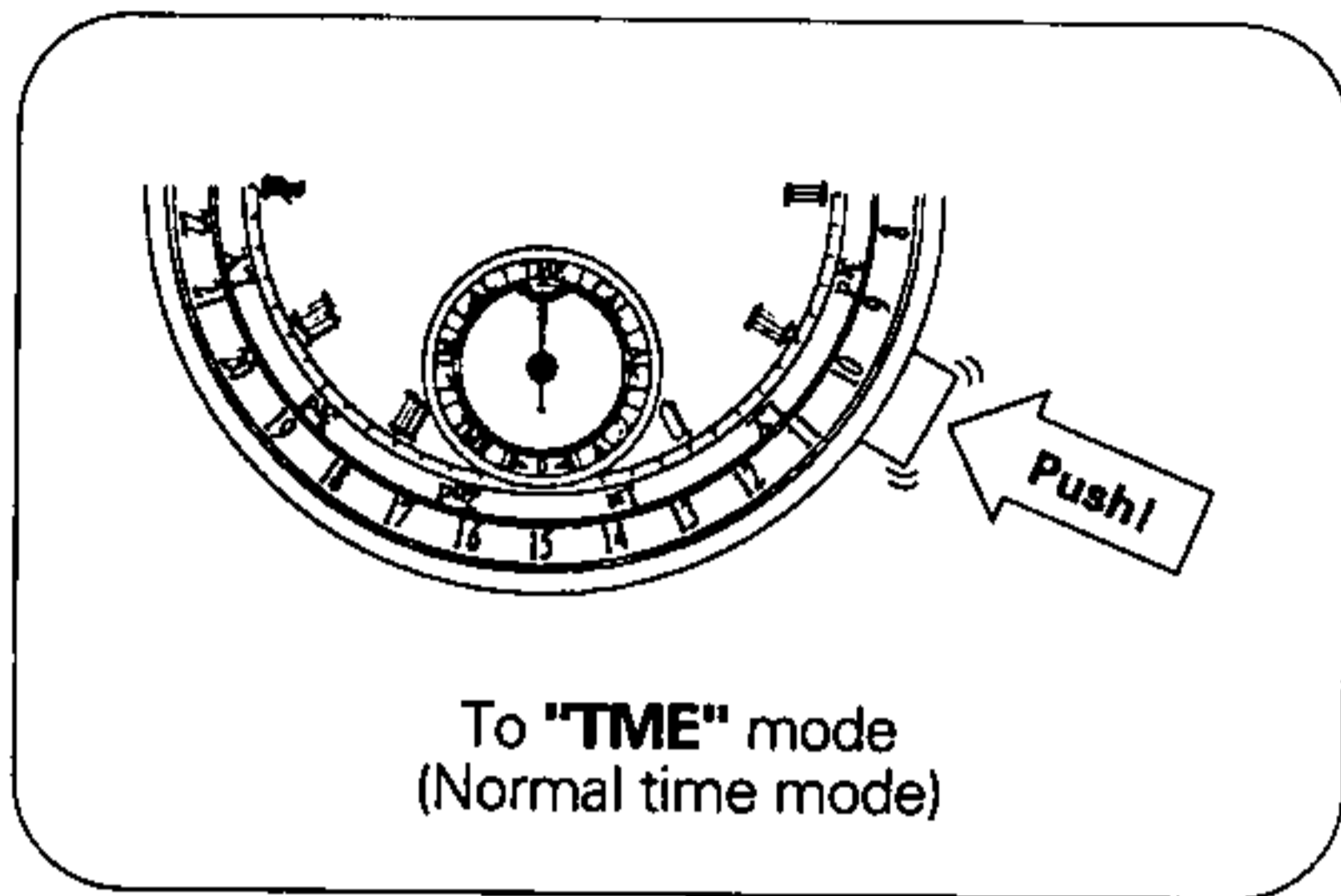

**M** button in the normal position.

Auxiliary time is displayed as Local time

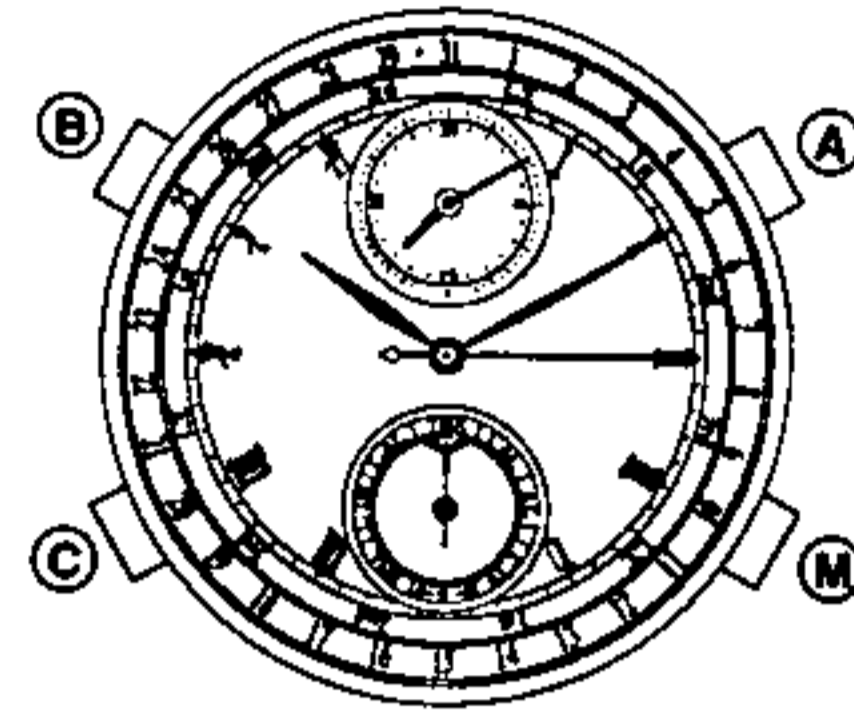

### Setting procedures

Pull the **M** button out to the first step

Aux. time displays Home time under 24-hour system

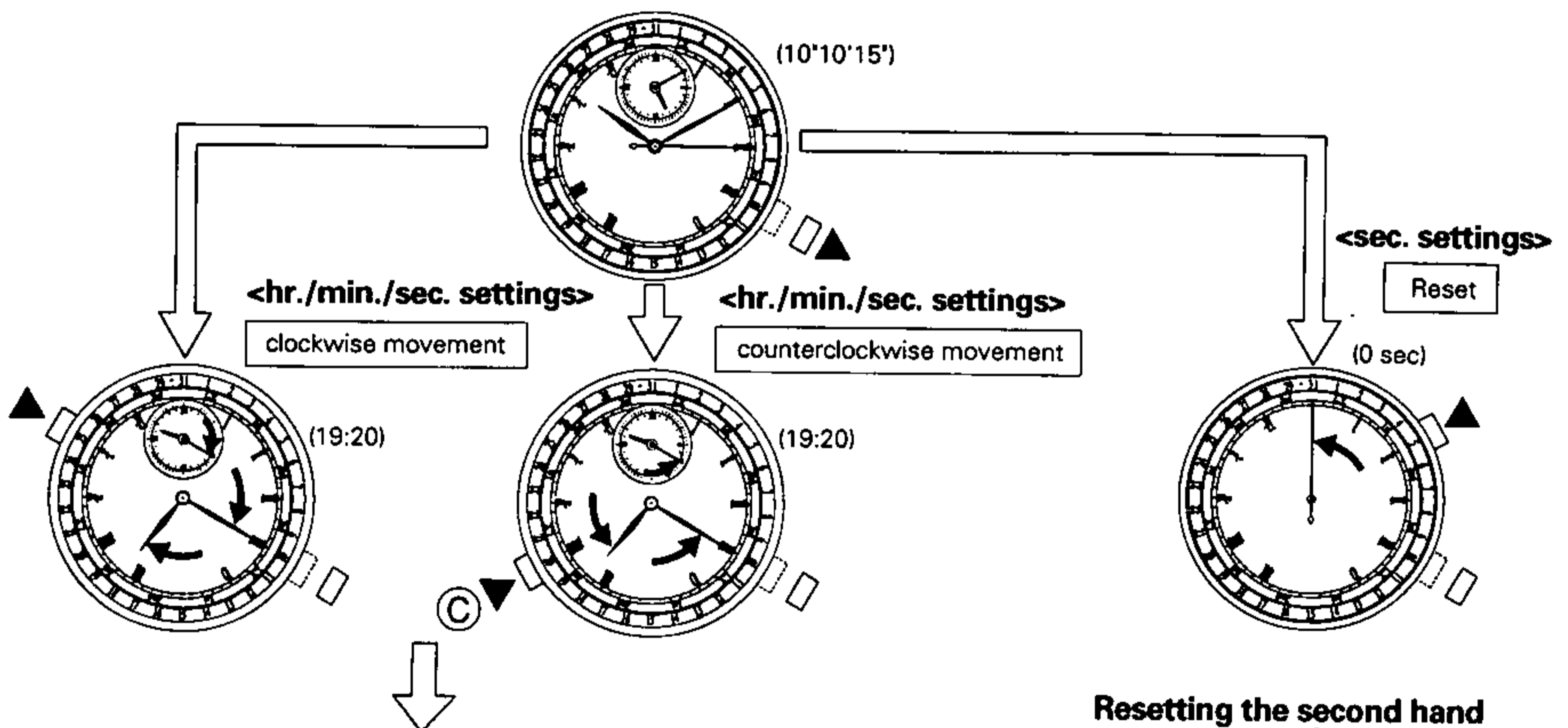

Push the **M** button in to the normal position

Aux. time displays Local time

(Time setting complete at 19:20'00')

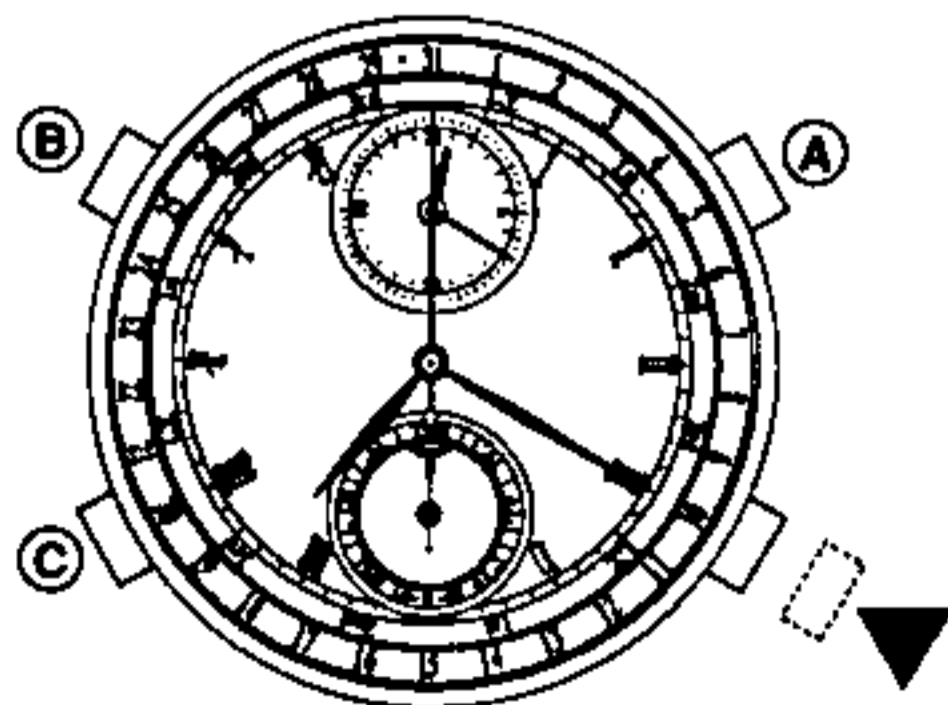

### Resetting the second hand

- Pressing the **A** button while the second hand is **between 0–29 seconds** will not alter the minute hand position.
- Pressing the **A** button while the second hand is **between 30–59 seconds** will advance the minute hand to the next full minute position.



- ☆ The hour/minute hands and auxiliary hour/minute hands are synchronized.
- ☆ Press and hold down either the (B) or (C) button to use the quick-advance feature.
- ☆ Hand movement is about twice as fast after the first revolution. (clockwise movement only).

### 3. SETTING THE CALENDAR (CAL)

Setting the calendar from May 5, 1990 to September 9, 1992.

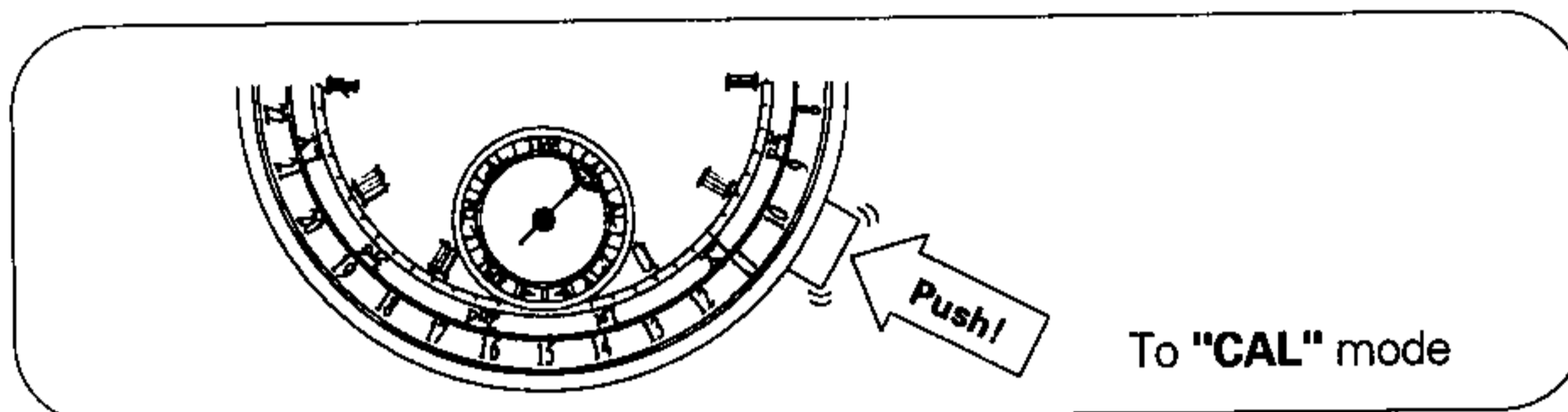

#### Leap Year Chart

L.Y.	1988	L.Y.	1992	L.Y.	1996	L.Y.	2000	L.Y.	2004	L.Y.	2008
1	1989	1	1993	1	1997	1	2001	1	2005	1	2009
2	1990	2	1994	2	1998	2	2002	2	2006	2	2010
3	1991	3	1995	3	1999	3	2003	3	2007	3	2011

#### < How to read the chart >

Leap years are indicated by L.Y.. The numbers 1, 2, 3 indicate the number of years that have passed since the last leap year.

**Example:** The year 1992 will be a leap year, and 1993 will be the first year after the leap year.

#### Leap year display

From the leap year quick reference chart:

- 1990 is the second year following the leap year.
  - 1992 is a leap year.
  - On this watch 1 hour = 1 year when figuring the number of years since a leap year. There are three groupings of L.Y., +1, +2, +3 on the watch dial indicating the leap year and following years.
- When setting the leap year, as in the example at 1992, the hour hand need only be positioned over the closest L.Y. marking to complete the setting.

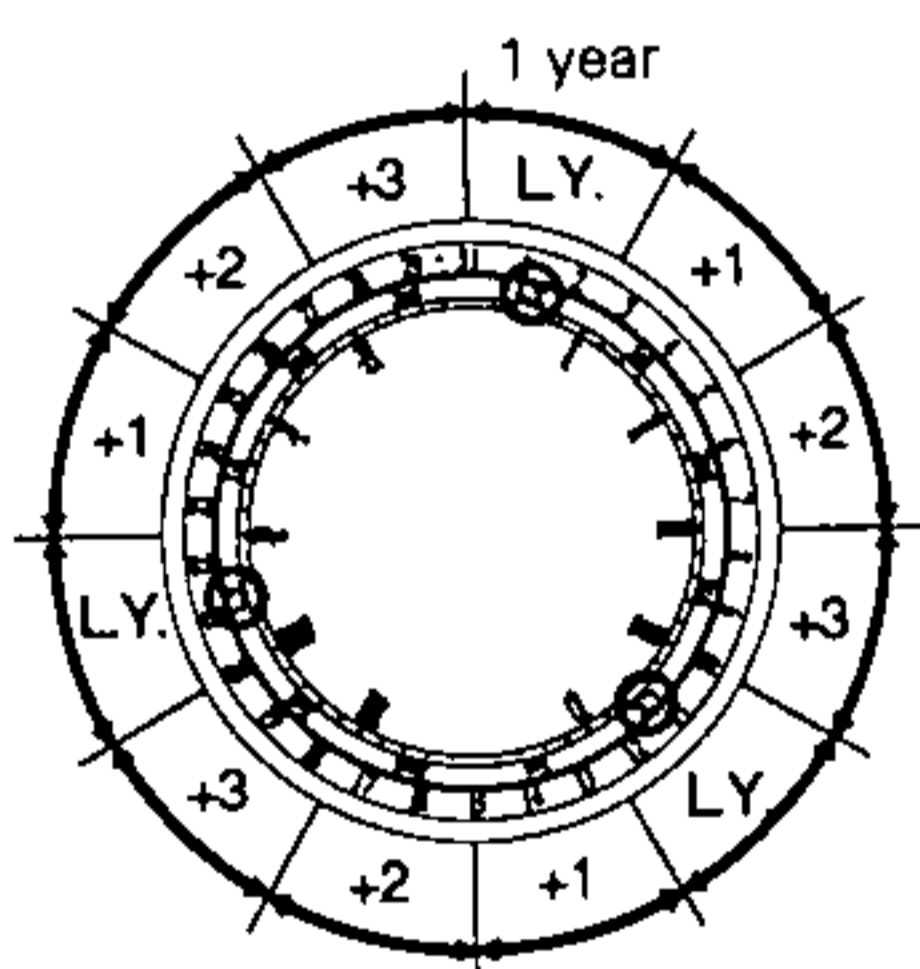

#### < (M) button normal position >

(May 5, 1990)

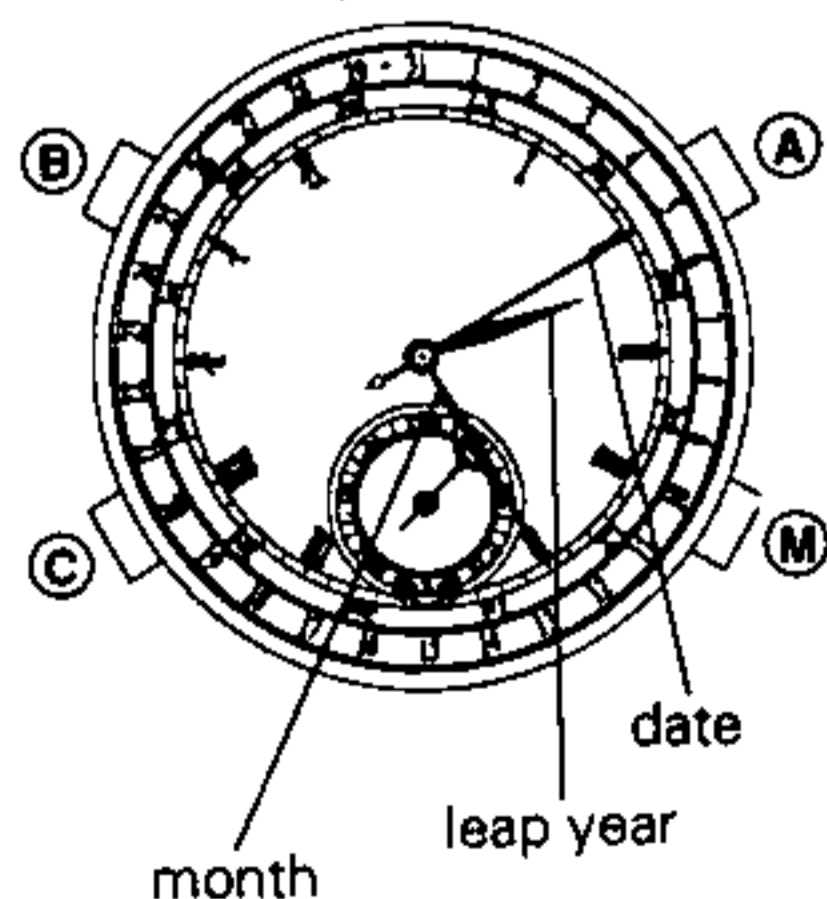

#### Adjustment-free calendar

The calendar feature on this watch requires no adjustment at the end of the month or for leap years. Under normal conditions, this feature provides the user with a complete adjustment-free calendar.

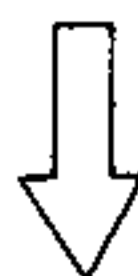

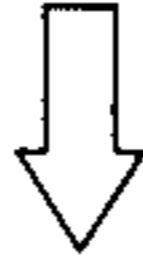

**Setting procedures**

- ☆ The year and month are synchronized; the date must be independently set.
- ☆ Press and hold down any of the (A), (B), (C) buttons for the quick-advance feature.

**<(M) button: 1st step>**

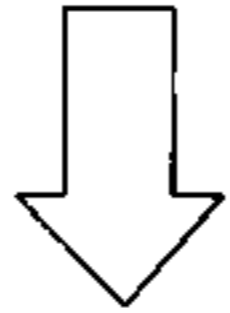
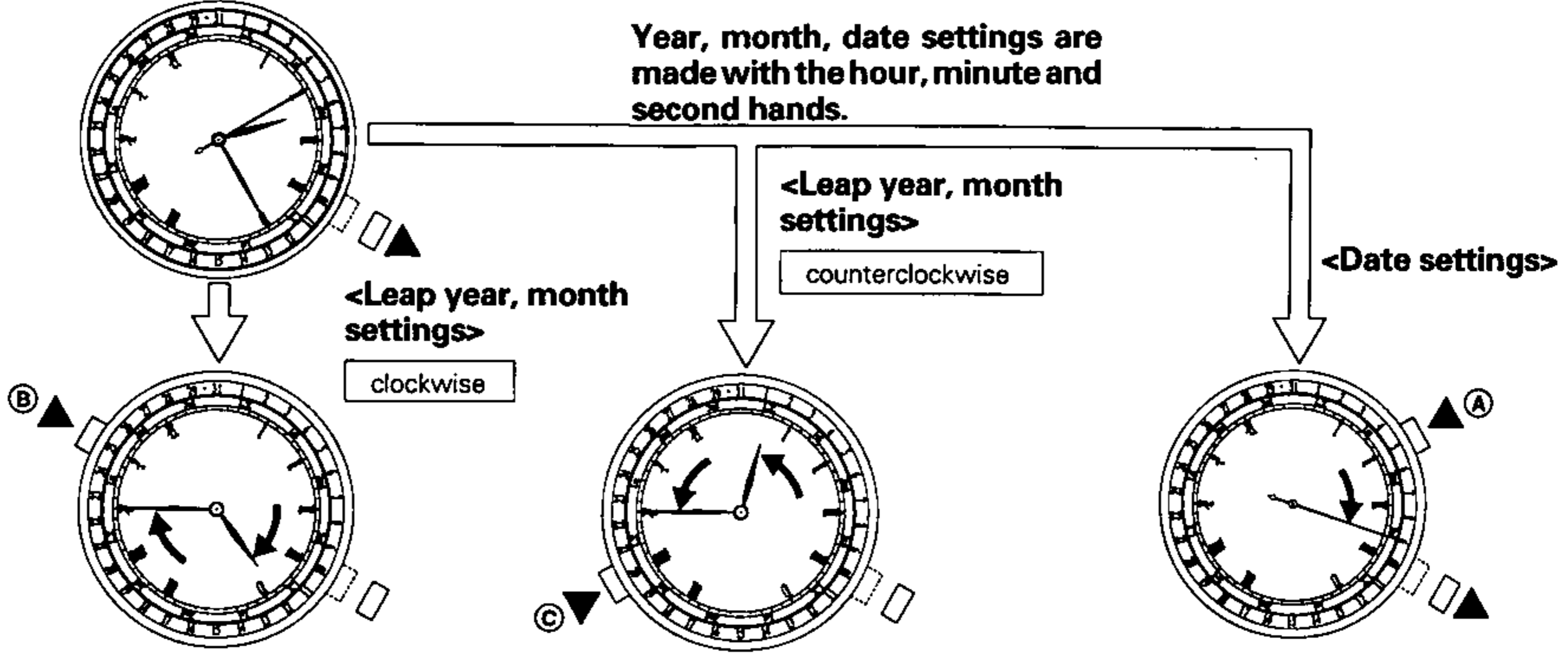

**<Push the (M) button in to the normal position>**

(Calendar setting complete at September 9, 1992, leap year)

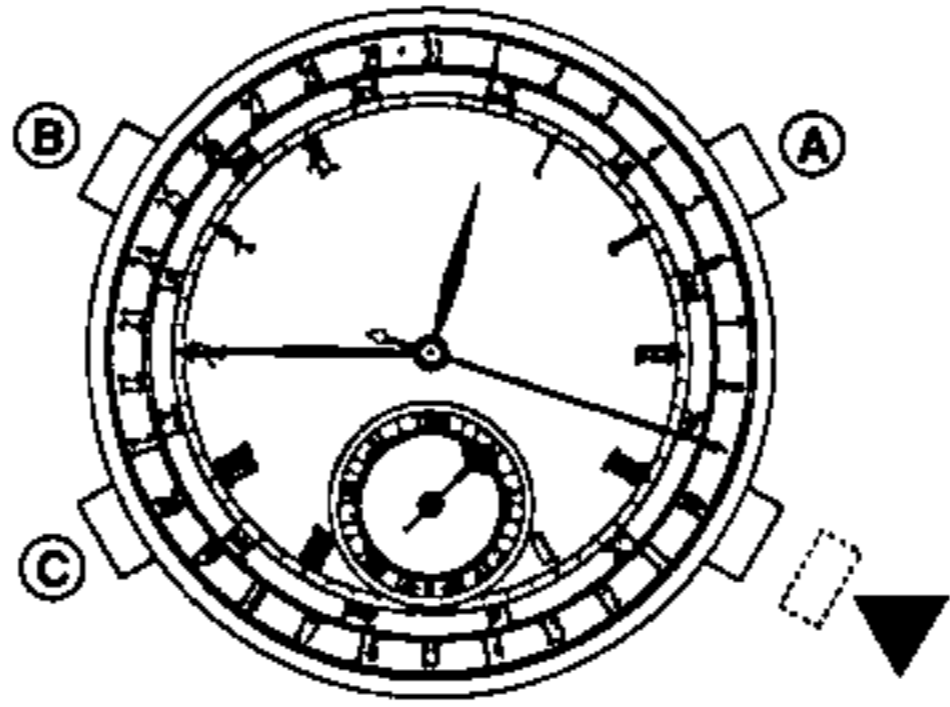

**Automatic date correction**  
When a nonexistent date is entered, the watch will automatically set the date to the 1st of the following month when the (M) button is pushed in to the normal position.  
**(For example: Feb 30 → March 1st)**

#### 4. SETTING THE QUICK-SETTING ALARM (AL-1)

Setting the alarm to ring after 50 minutes from the current time, (19:20'00") at 20:10'00".

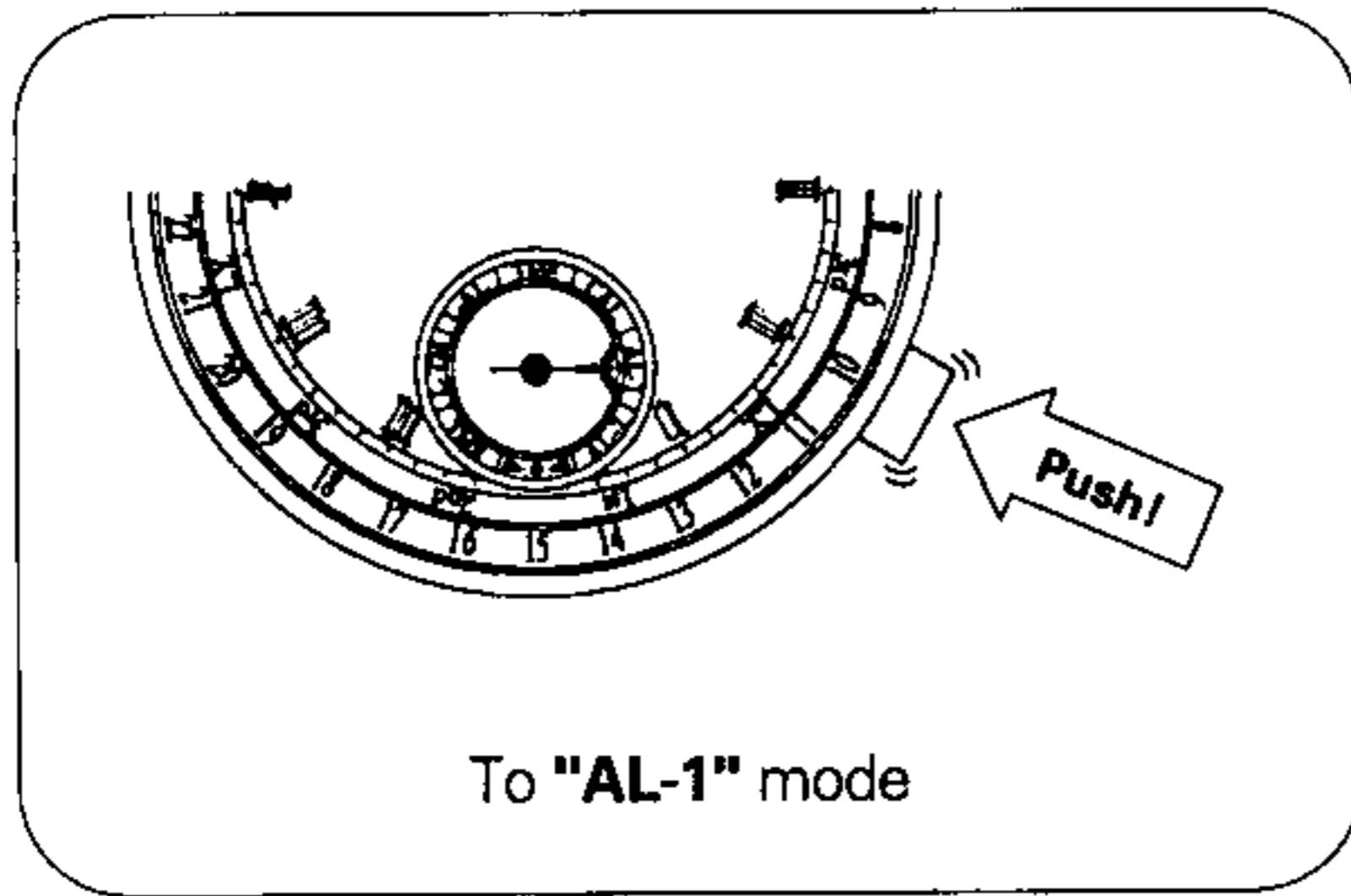

Alarm can be set in this position

Ⓜ button normal position

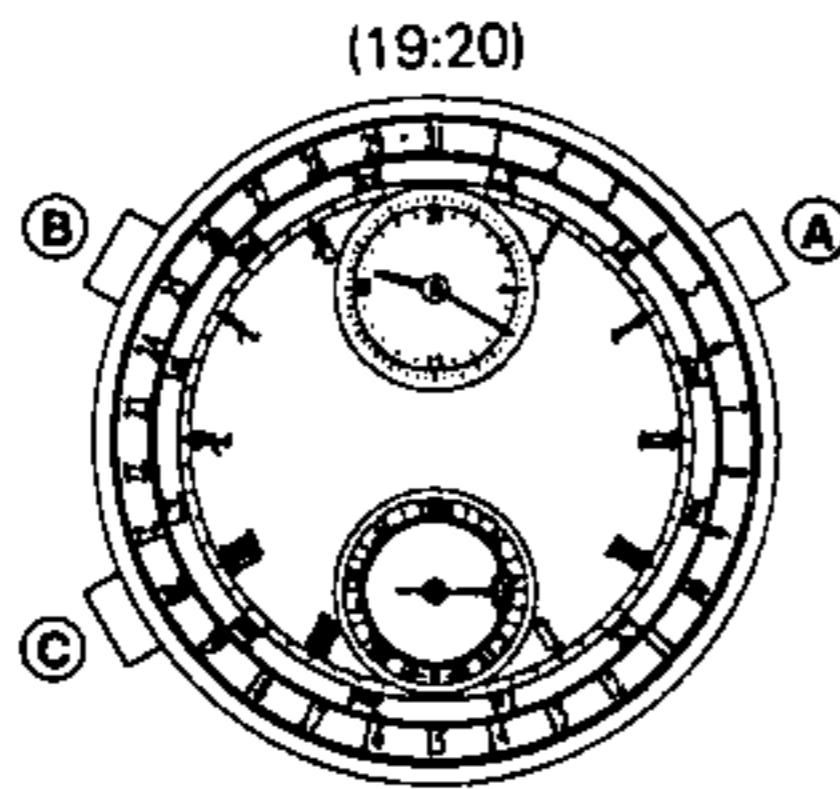

<Sound monitor>

(5 seconds)

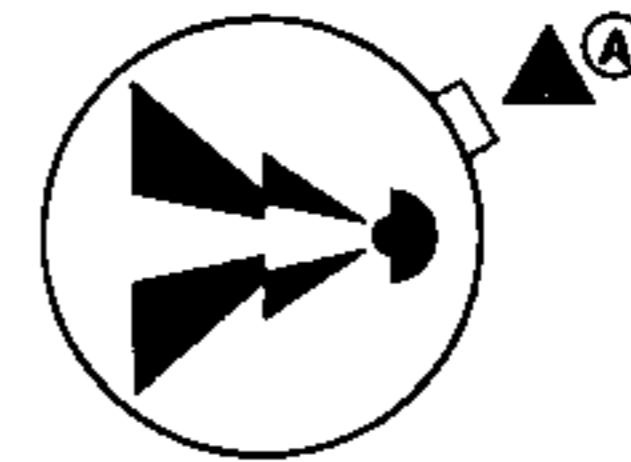

- Sound can be monitored by pressing the Ⓐ button when the alarm is OFF.

#### Setting procedures

<Aux. hour, minute settings>

clockwise

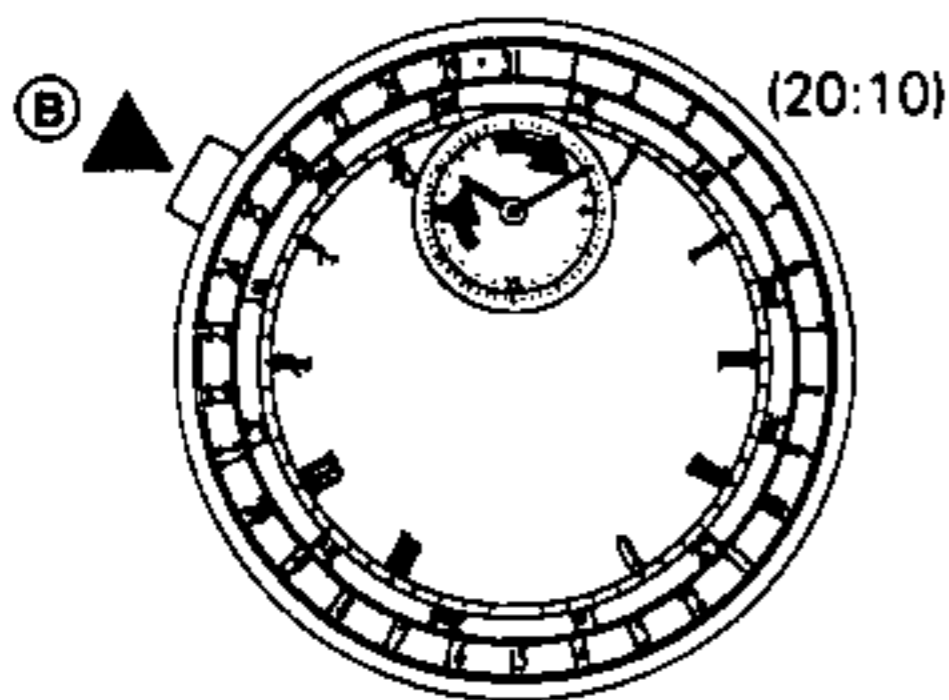

<Aux. hour, minute settings>

counterclockwise

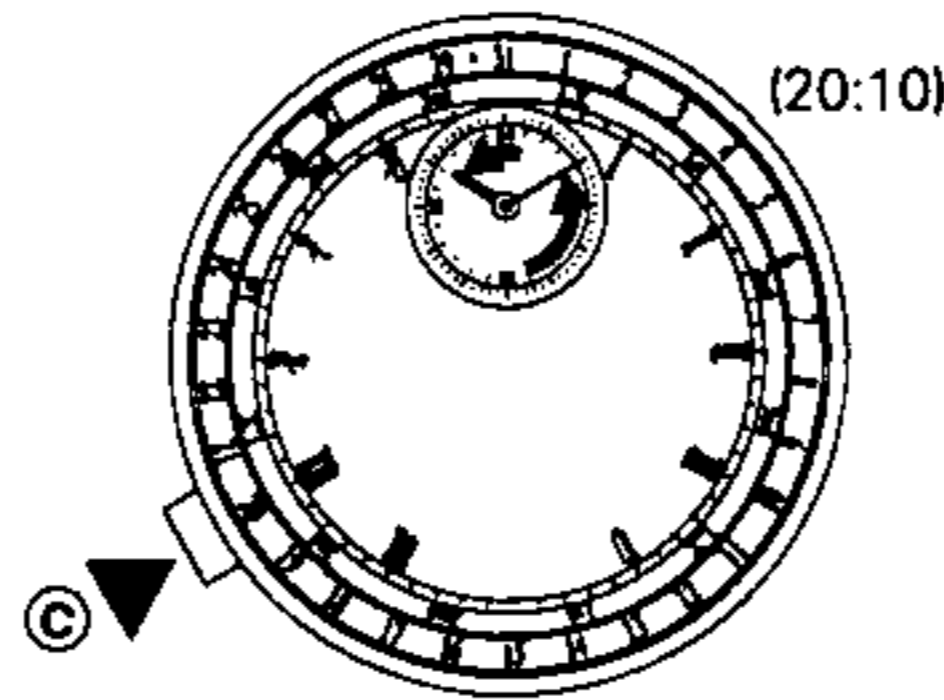

<Quick-setting alarm auto ON function>

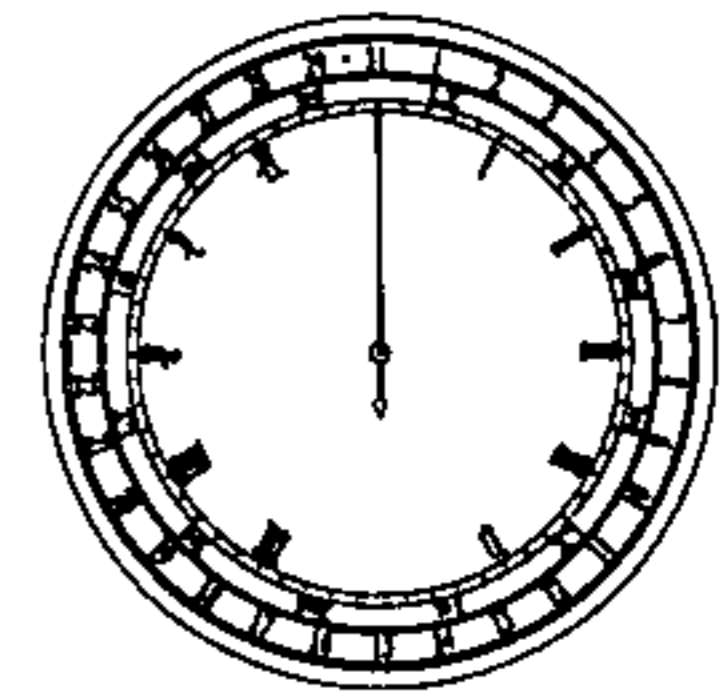

**Alarm ON:** second hand stops in the '0' position.

**Alarm OFF:** auxiliary time hands display the current time.

- ☆ Hour and minute hands display the current time (home time).
- ☆ Press and hold down either the Ⓑ or Ⓒ button for the quick-advance feature.
- ☆ Auxiliary hour and minute hand movement is about twice as fast after the first revolution (clockwise movement only).
- ☆ The auxiliary time display is a 24-hour system.

After adjusting the hour and minutes, the second hand returns to the '0' position and stops, regardless of whether the watch hands were turned clockwise or counterclockwise during setting procedures. **At this point, the alarm is now ON.**



<Setting of the quick-set alarm is complete>

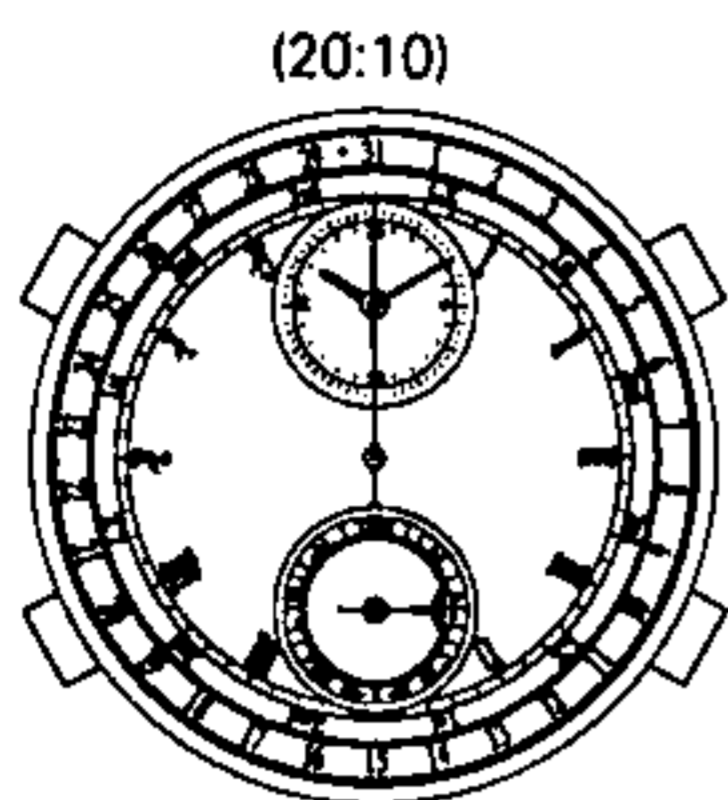

<Canceling the quick-set alarm setting>

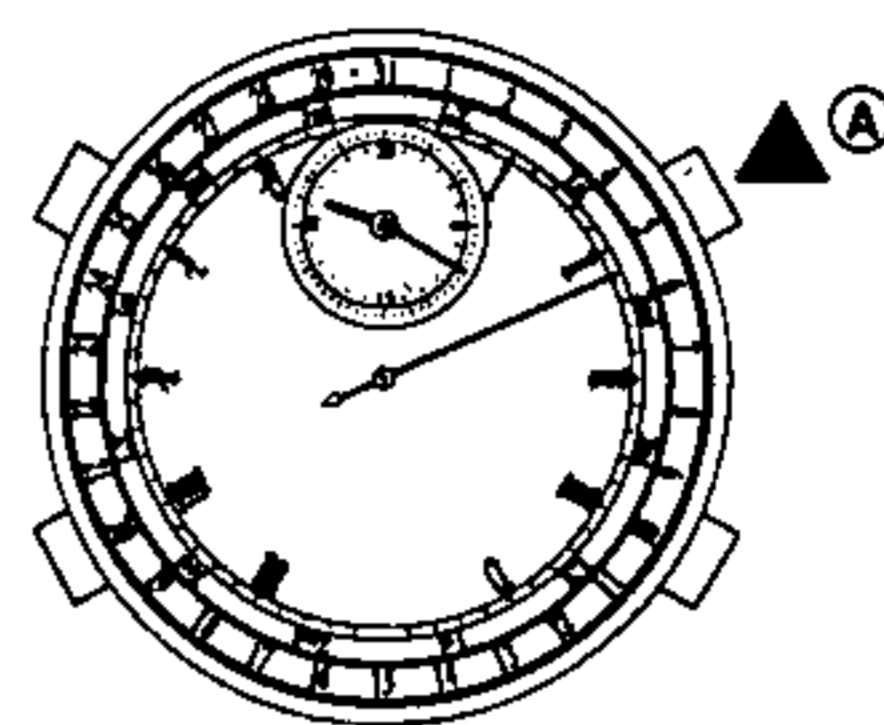

- Press the **A** button after setting the alarm and the auxiliary time hands will display the current time and **the quick-set alarm will be turned OFF.**

## 5. SETTING THE DAILY ALARM (AL-2)

Setting the daily alarm to ring everyday at 15:00.

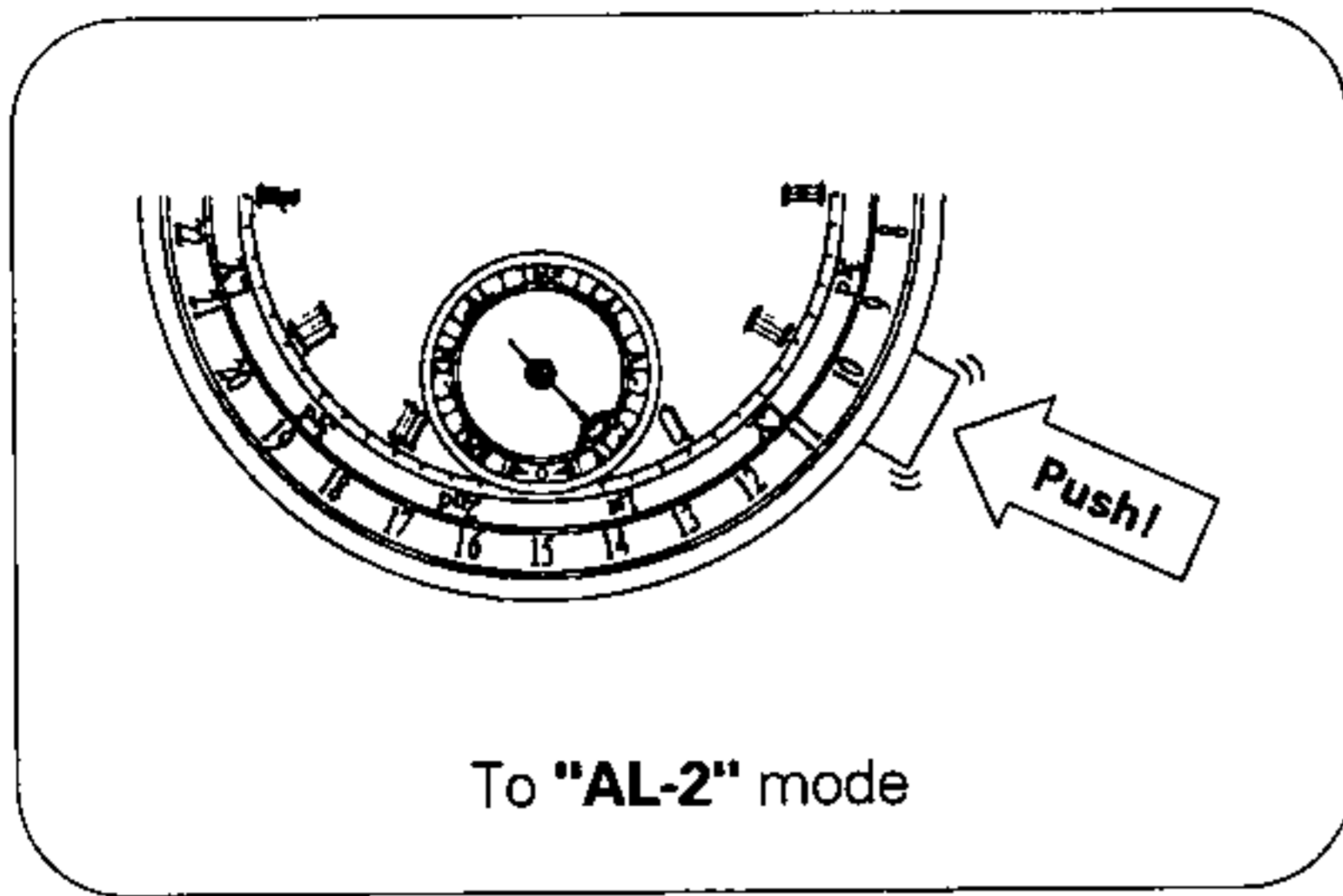

- **Use the auxiliary hour, minute, second hands to set the alarm**

After the alarm time has been set, the alarm will sound everyday at the same time for 15 second.

- **Alarm sound switch**

Use the second hand to set the alarm ON and OFF.

This switch lets you choose between 2 sounds (loud or soft) for the alarm.

<M button normal position>

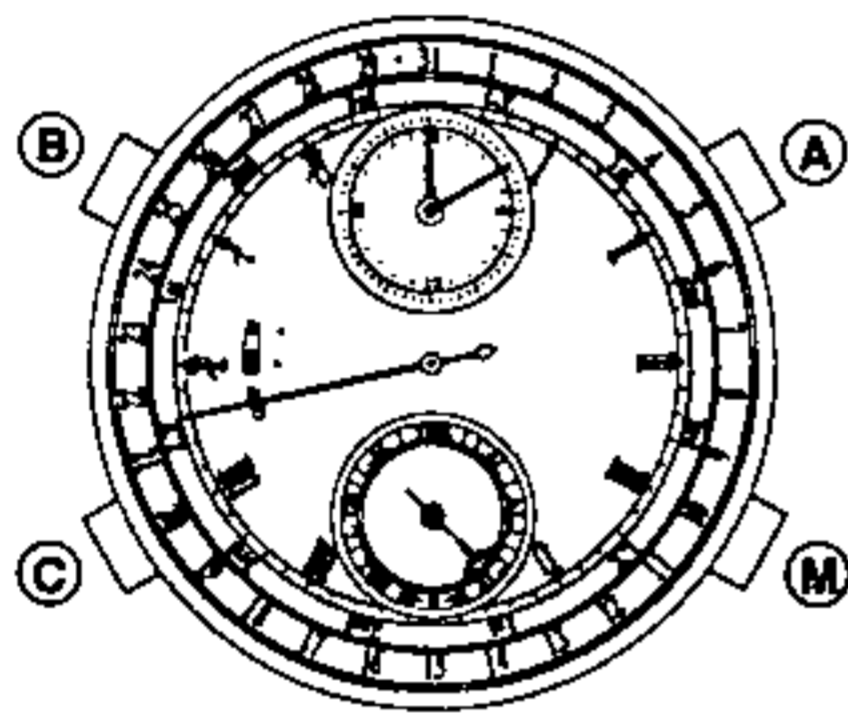

<Sound monitor>

(8 seconds)

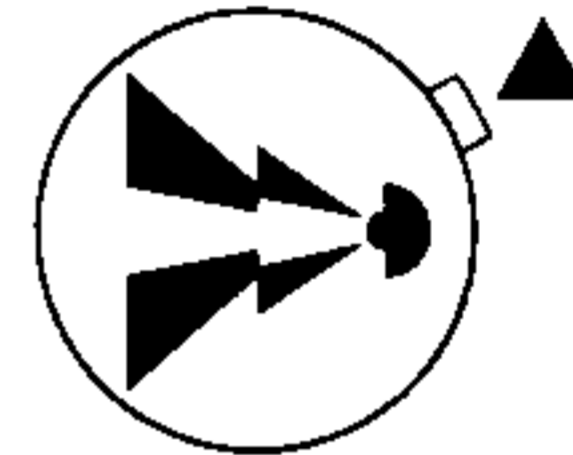

- Sound can be monitored by pressing the (A) button when the daily alarm is ON or OFF.

Setting procedures

<Pull the (M) button out to the 1st step>

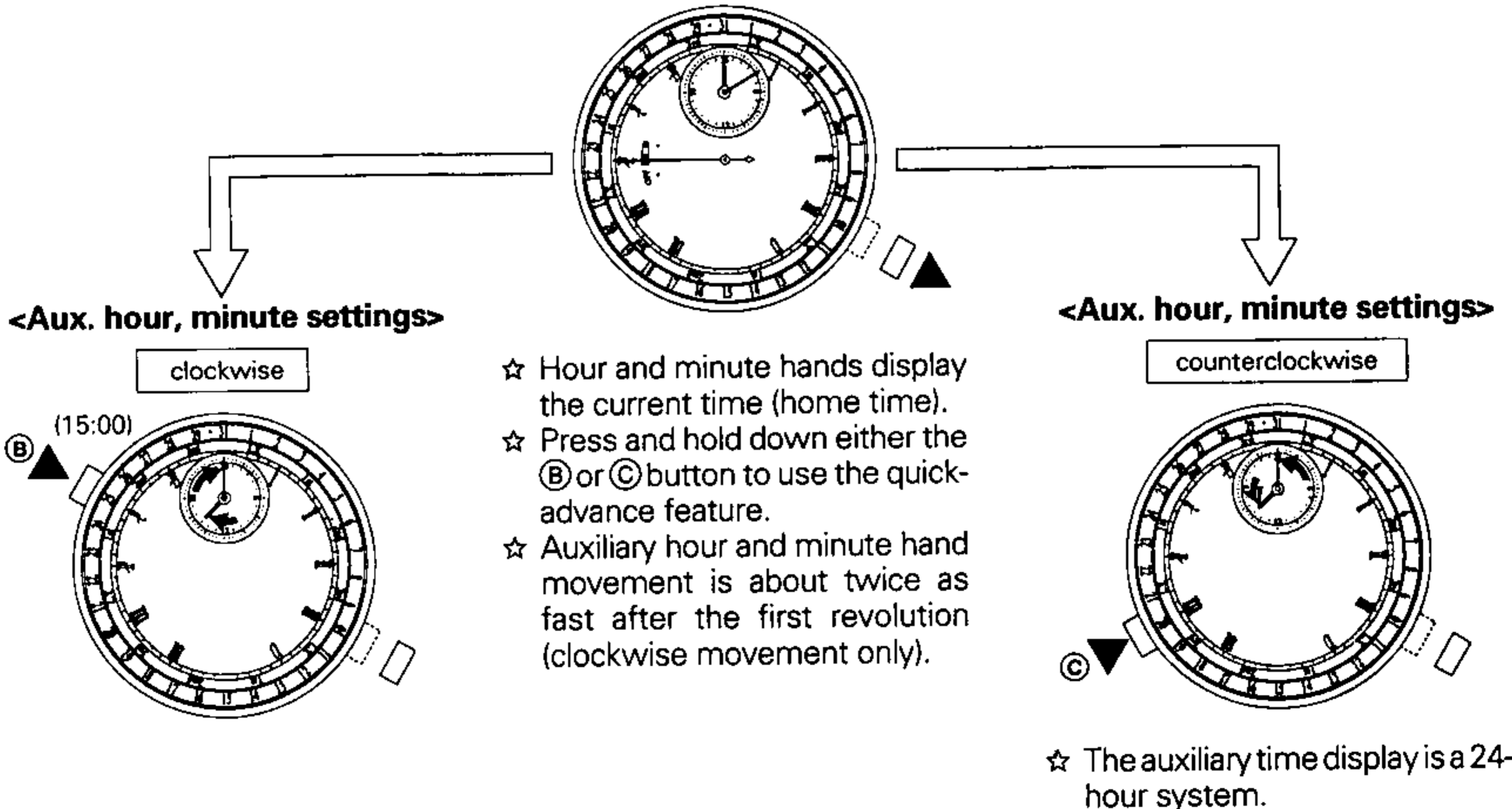



**Daily alarm auto ON**  
**Daily alarm sound selector**

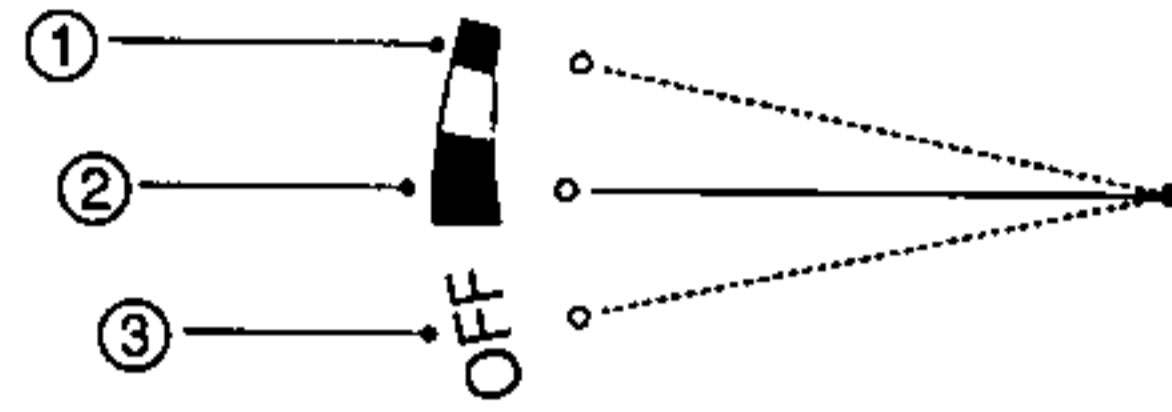
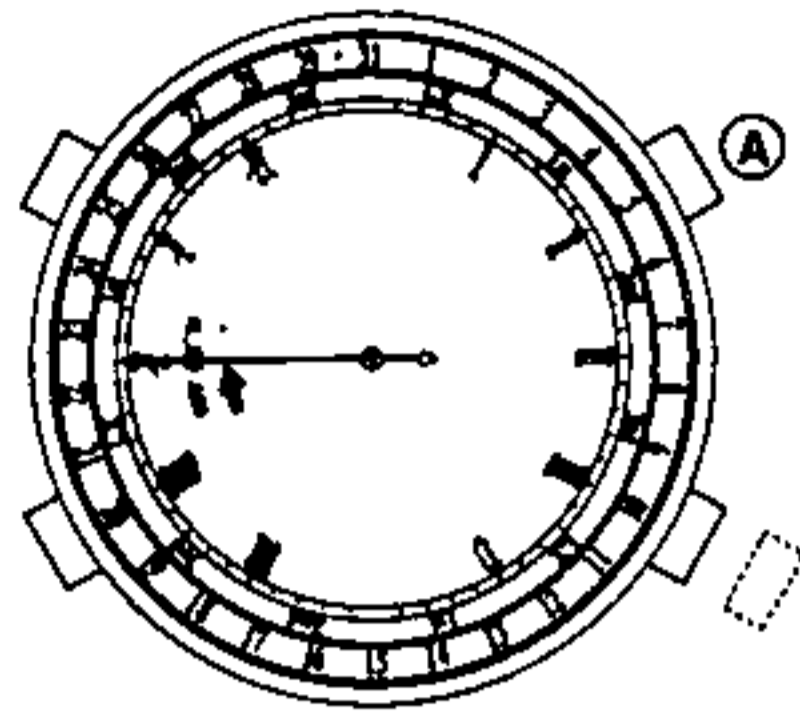

- Pull the (M) button out to the first step; the second hand moves to the (2)nd position and the alarm is turned ON.
- Press the (A) button to switch the sound ON and OFF. (The level of the alarm sound in position (1) is softer than position (2).)

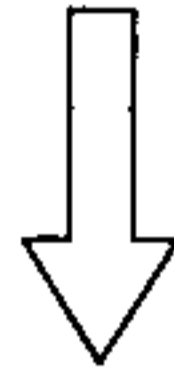

**[Push the (M) button into the normal position]**  
**Daily alarm setting is complete**

(15:00)

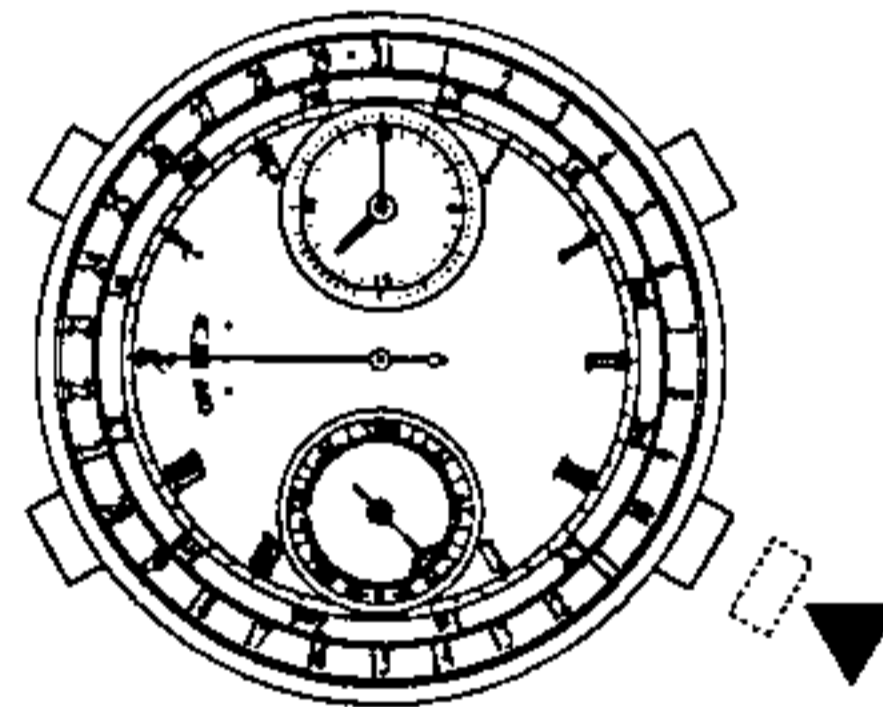



## 6. SETTING THE TIMER (TMR)

Setting the timer to 10 minutes.

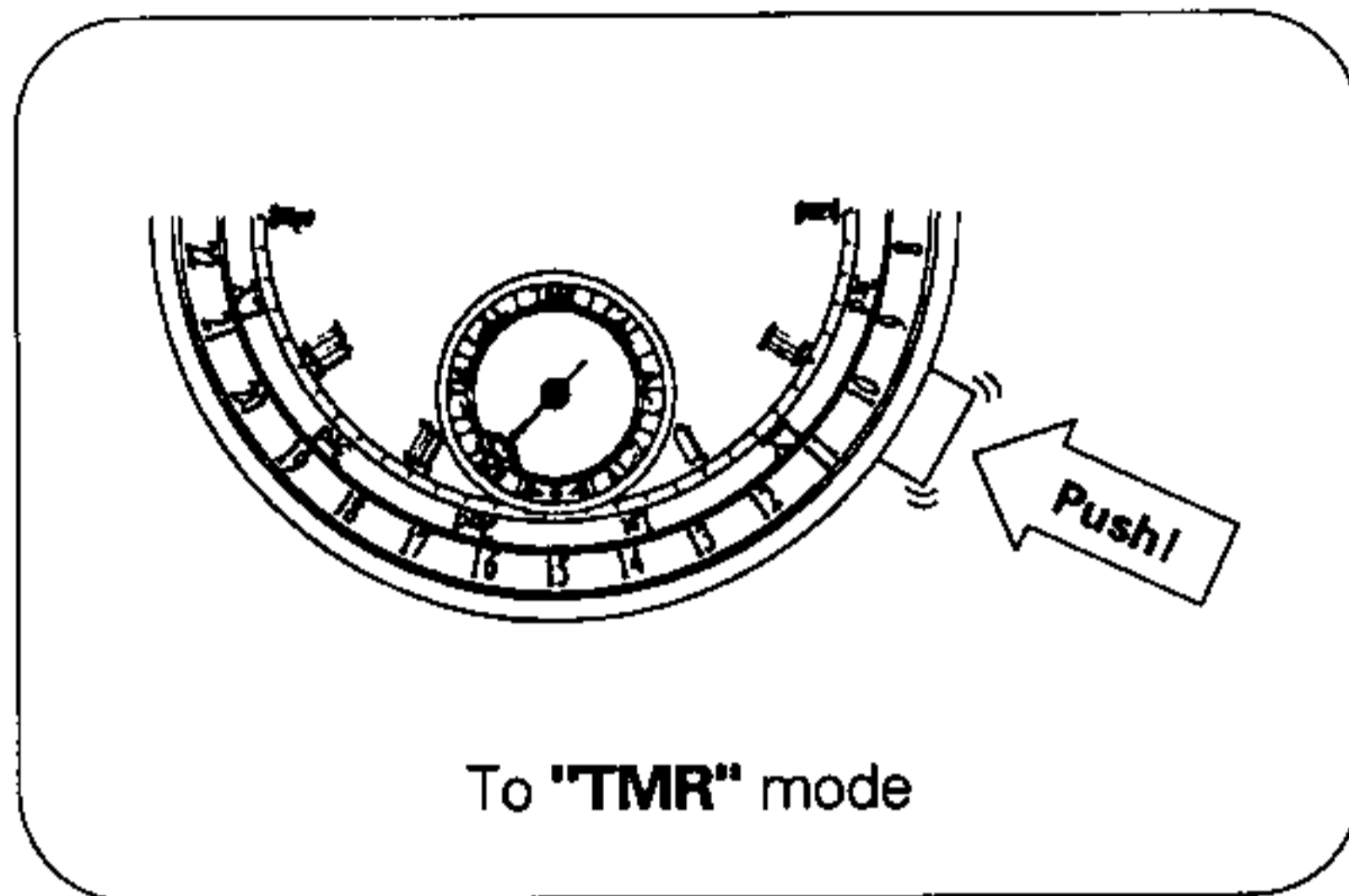

- **Timer range:** 24 hours in 1-minute intervals.
- **Flyback feature:** This feature allows you to press the © button after the timer countdown has started to return the watch to the initial timer setting and automatically start the countdown over again.

<M button normal position>

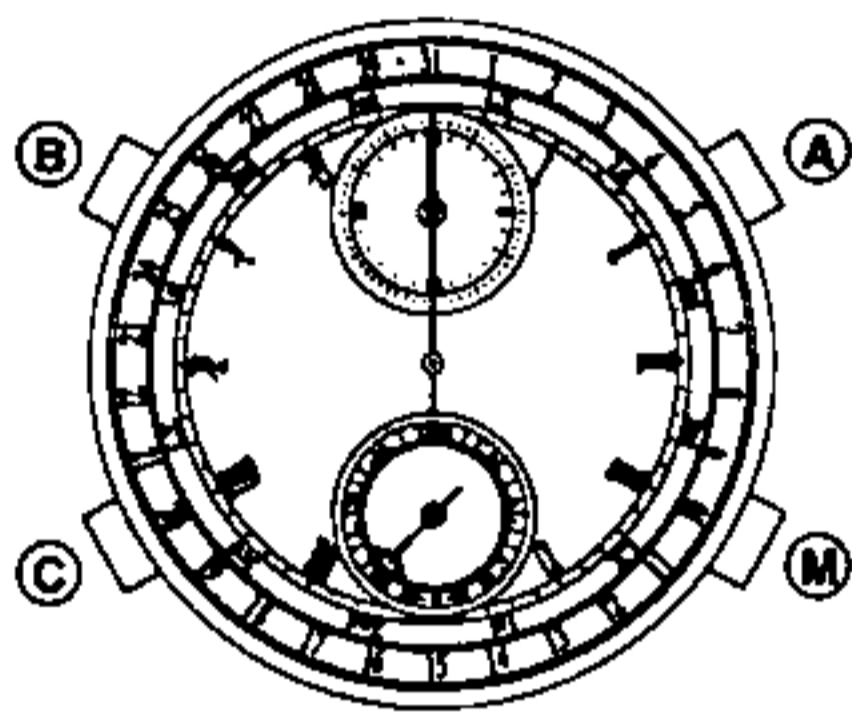

Setting procedures

<Pull the M button out to the 1st step>

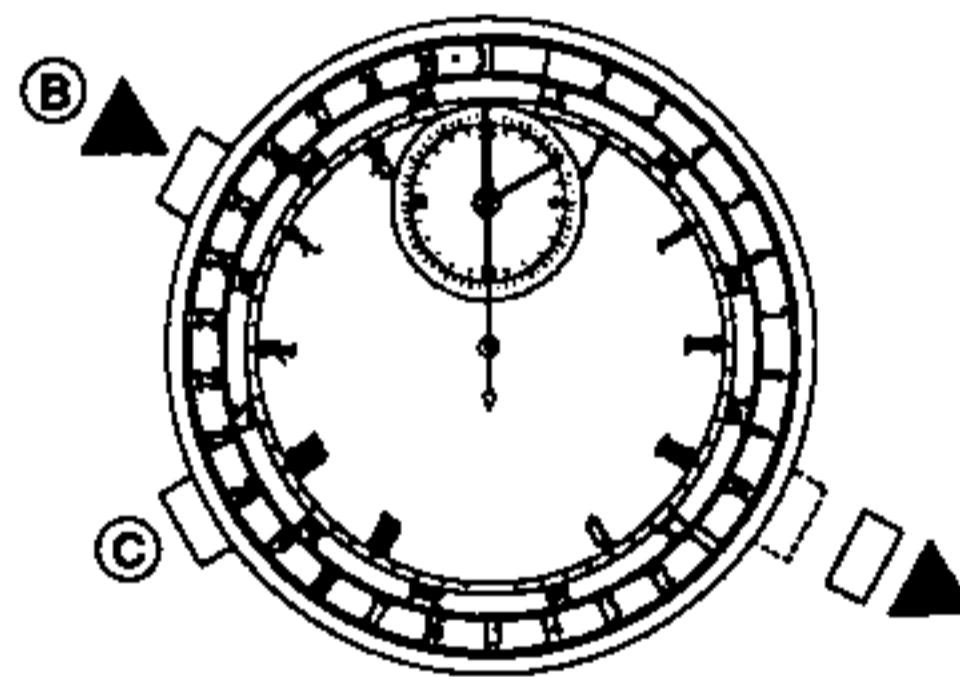

Timer settings are made with the auxiliary hour and minute hand.

- Press the © button for clockwise adjustments.
- Press the © button for counterclockwise adjustments.

<Push the (M) button in to the normal position>

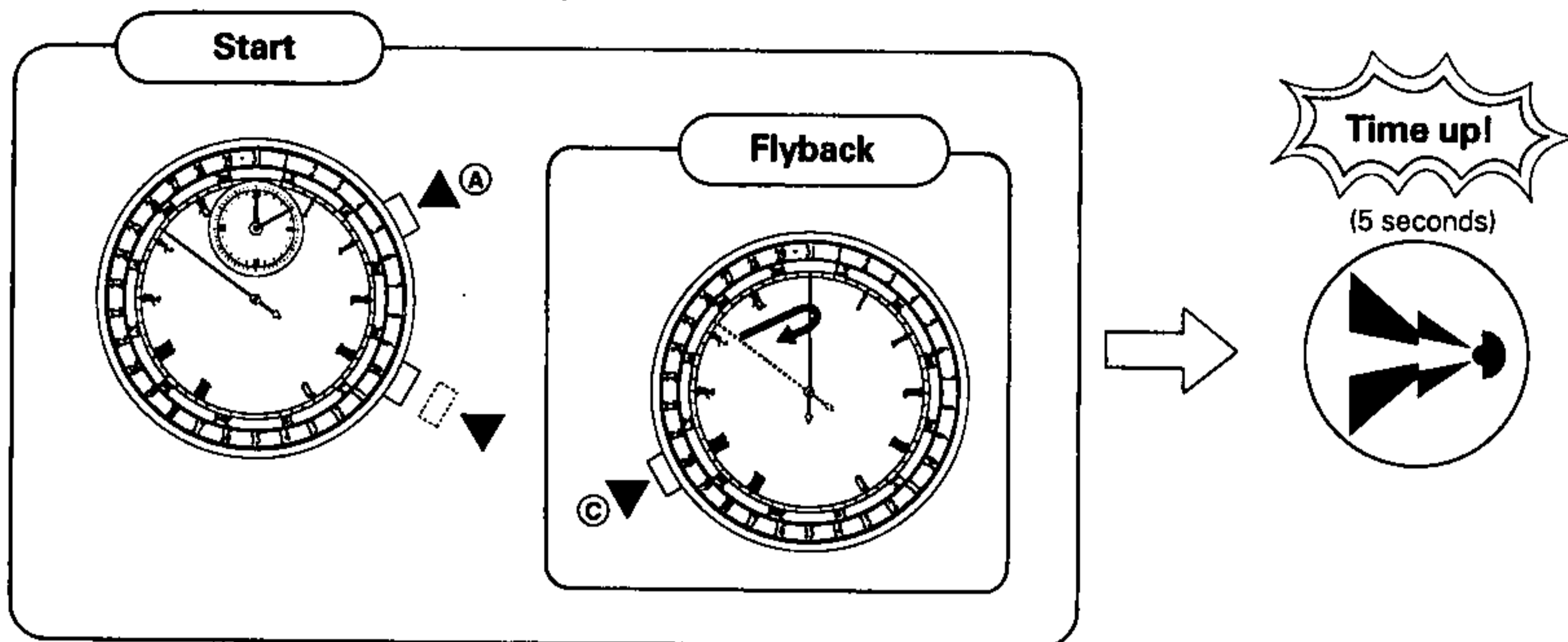

Stop

**Reset**  
(returns to the initial  
timer setting position)

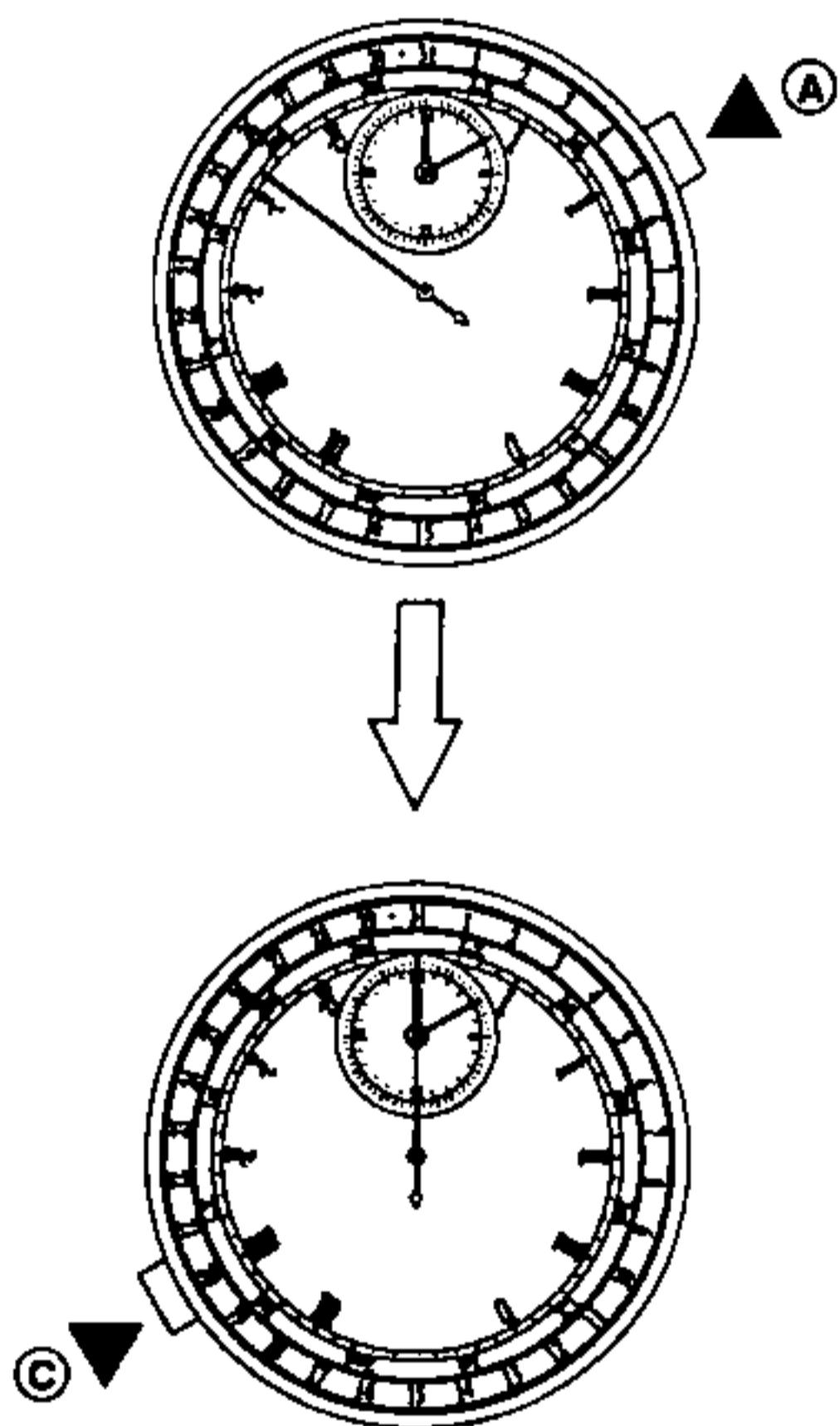

- ☆ A confirmation beep sounds with each start, stop, reset and flyback operation.
- ☆ Hour and minute hands display the current time (home time).
- ☆ Press and hold down either the (B) or (C) button to use the quick-advance feature.
- ☆ Auxiliary hour and minute hand movement is about twice as fast after the first revolution (clockwise movement only).

## 7. SETTING THE LOCAL TIME (L-TM)

Changing the local time from 00:20'00" to 15:20'20".

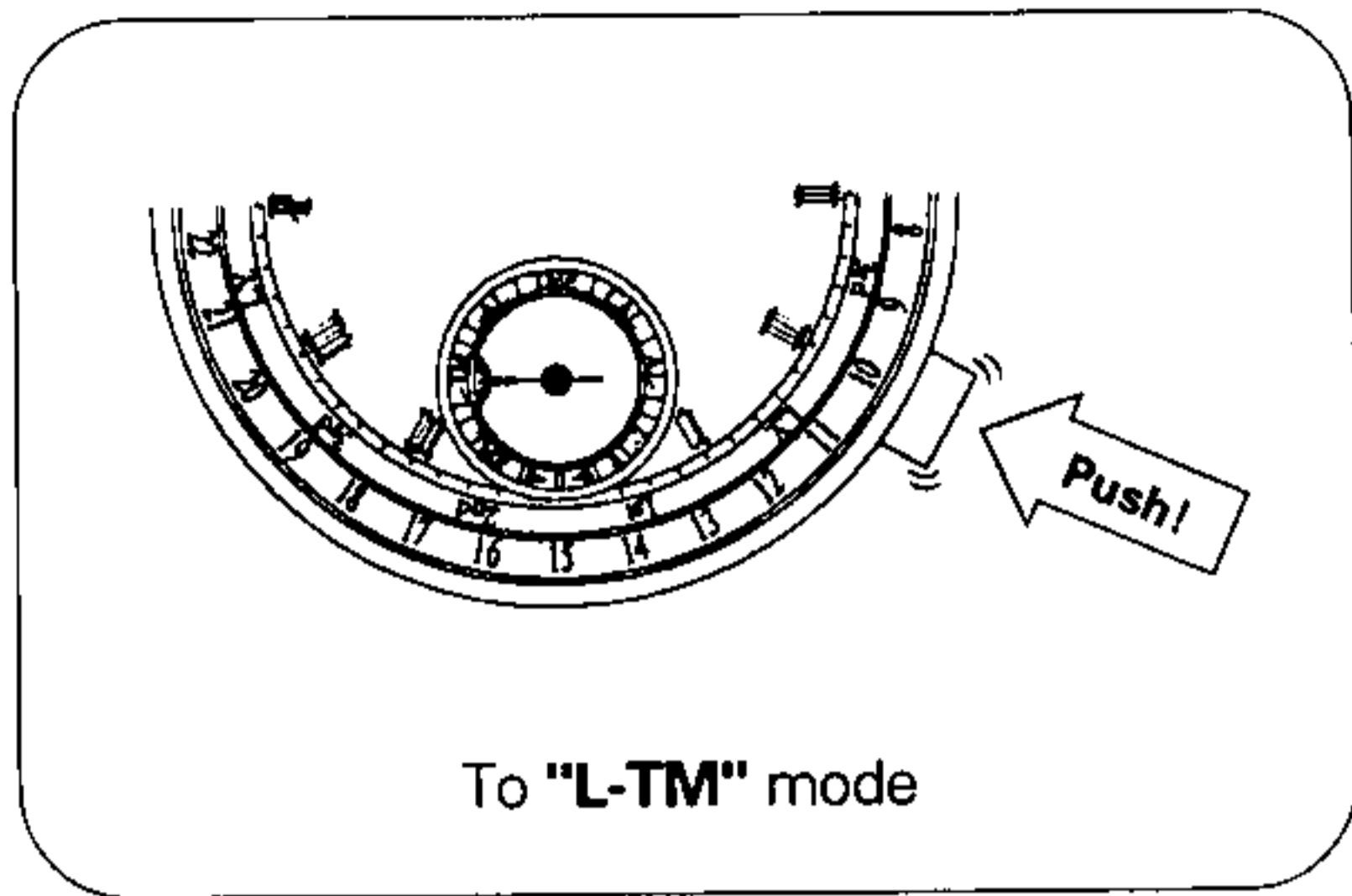

- During business trips or travel, the Dual time feature can be used by setting the watch to the local time.
- When the (M) button is in the normal position the auxiliary hour and minute hands display the home time.

### Setting procedures

To set the hour and minute hands to the local time.

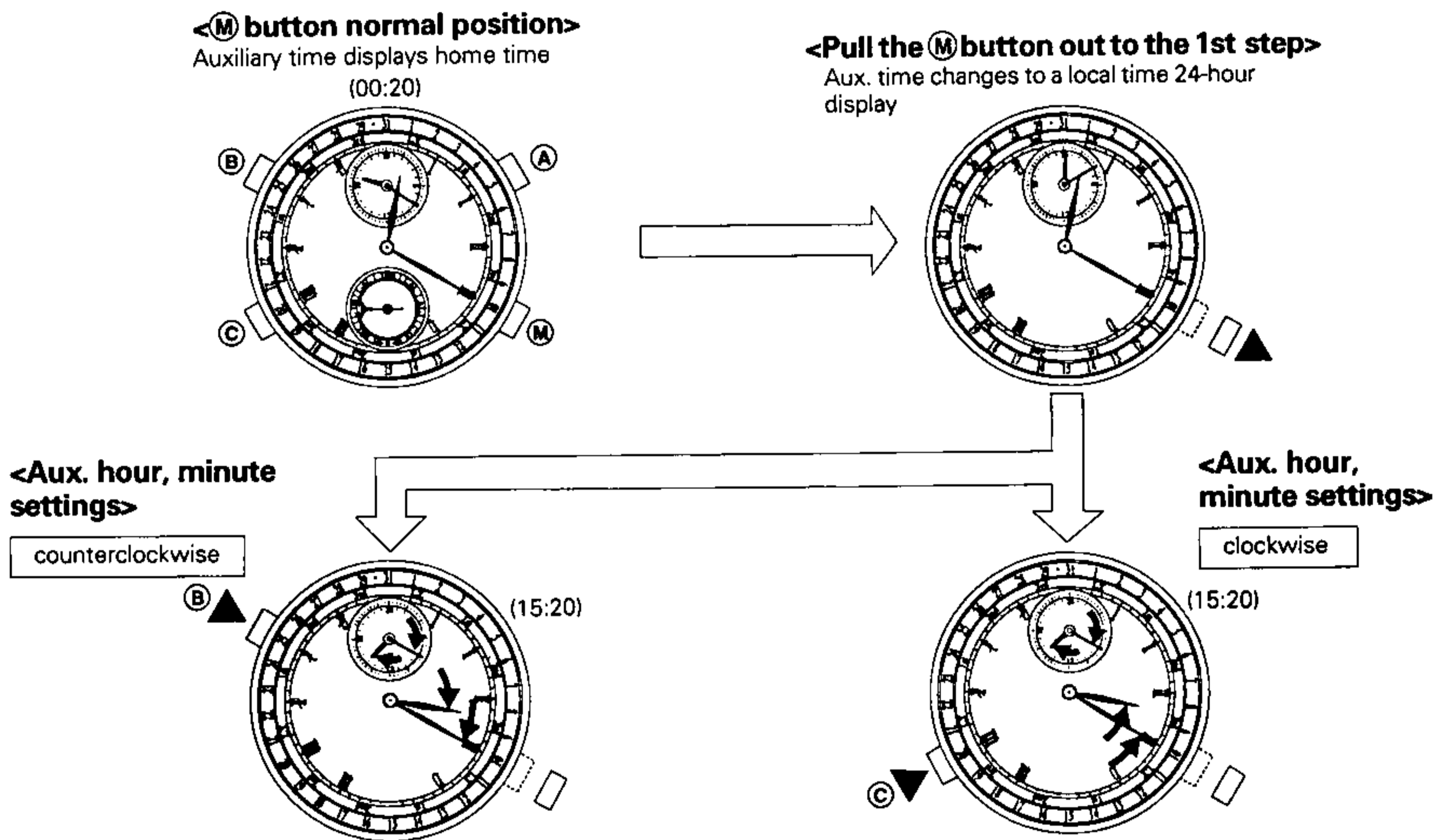

- ☆ Hour/minute/auxiliary hour/minute hands are synchronized.
- ☆ Minute hand is adjustable in 30-minute increments only. Second hand is not adjustable.
- ☆ The auxiliary time display is a 24-hour system. Use it to select correct AM or PM.
- ☆ Press and hold down either the (B) or (C) button to use the quick-advance feature.



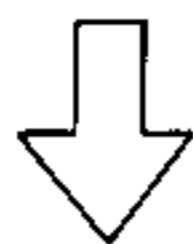

<Push the (M) button in to the normal position>

Auxiliary time returns to a home time display

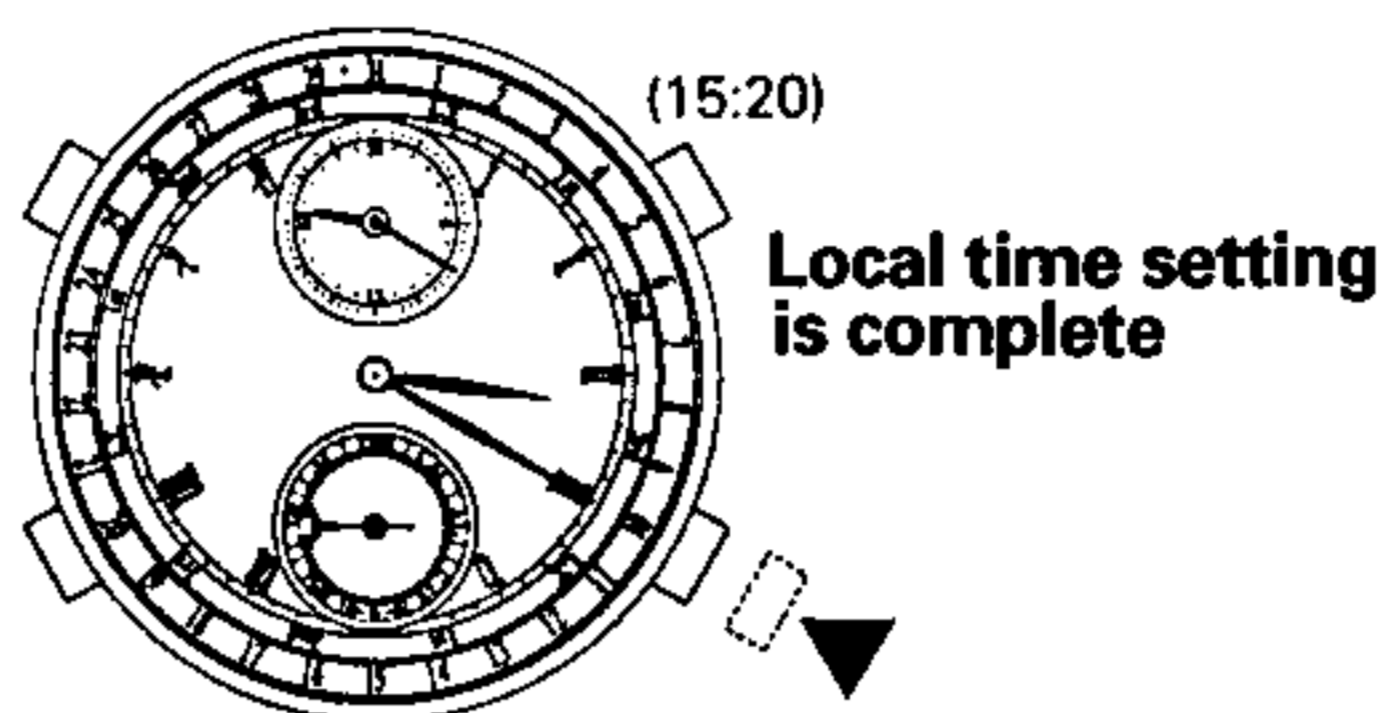

## 8. SETTING THE LOCAL TIME ALARM (L-AL)

Setting the local time alarm to ring everyday at 16:00.

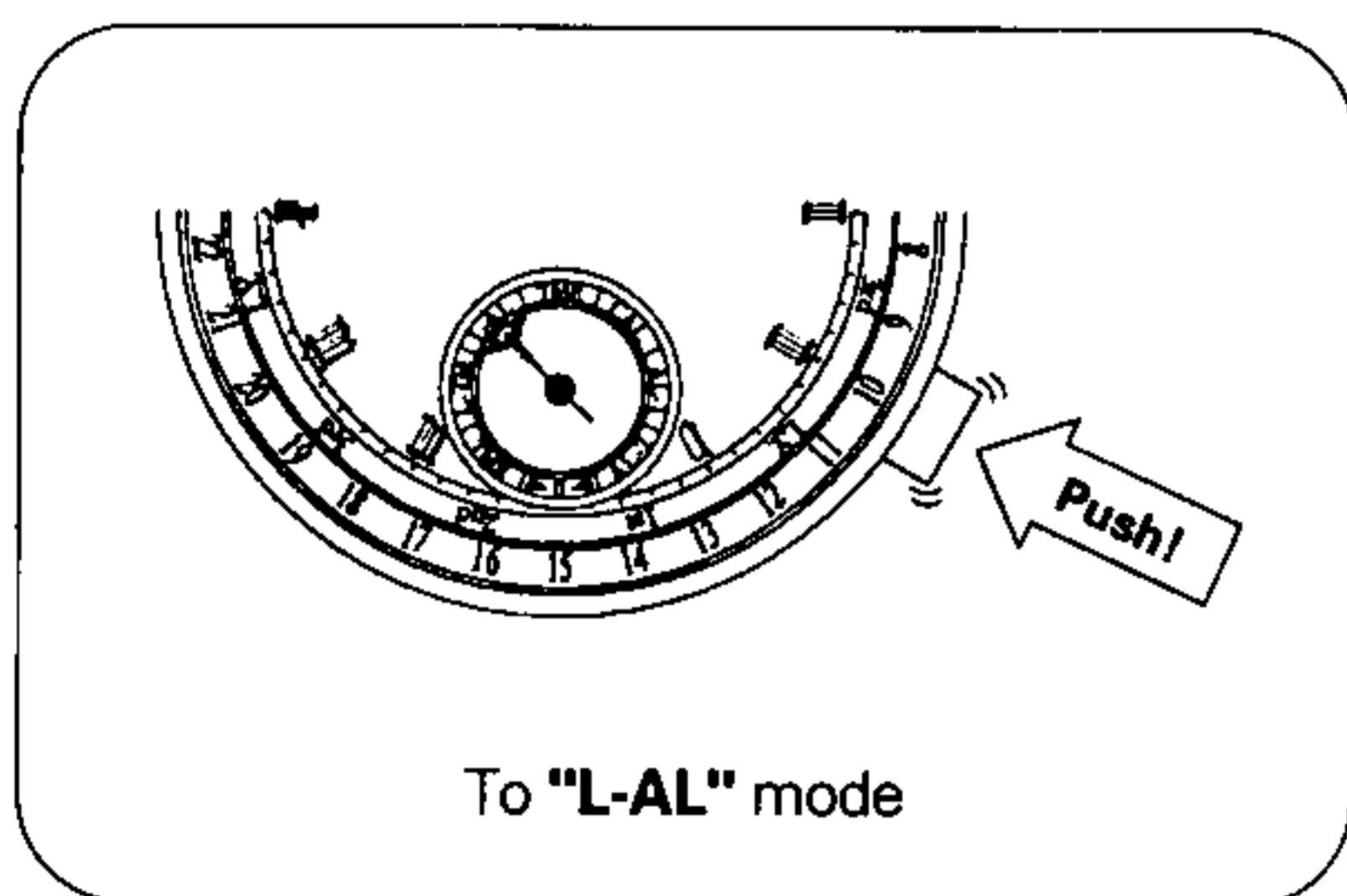

- **Use the auxiliary hour and minute hands to set the local time alarm.**

After the alarm time has been set once, the alarm will sound everyday at the same time according to the local time for 15 seconds.

- **Alarm sound switch**

This switch lets you choose between 2 sounds (soft or loud) for the alarm.

<(M) button normal position>

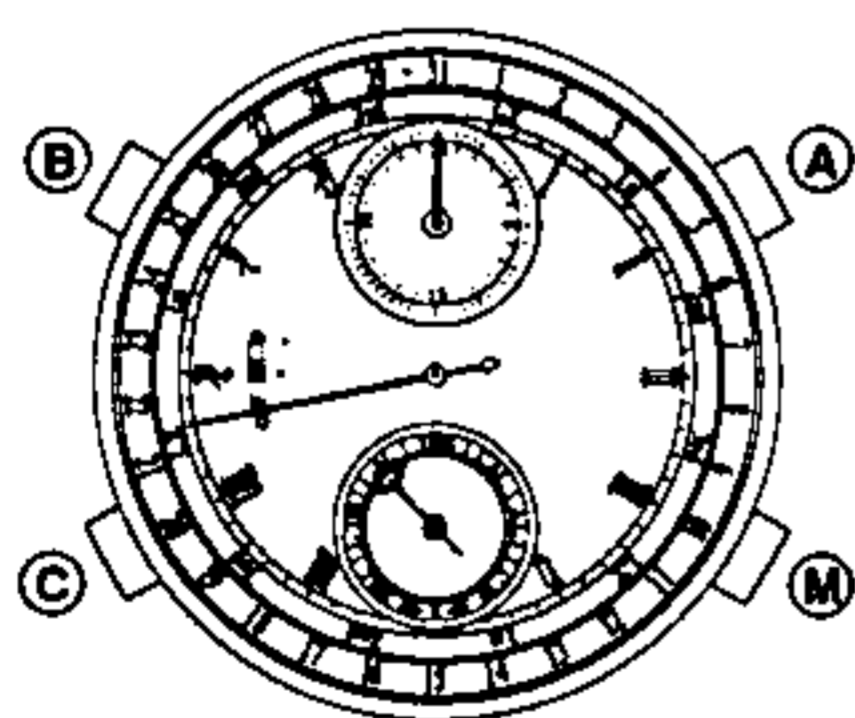

Sound monitor

(8 seconds)

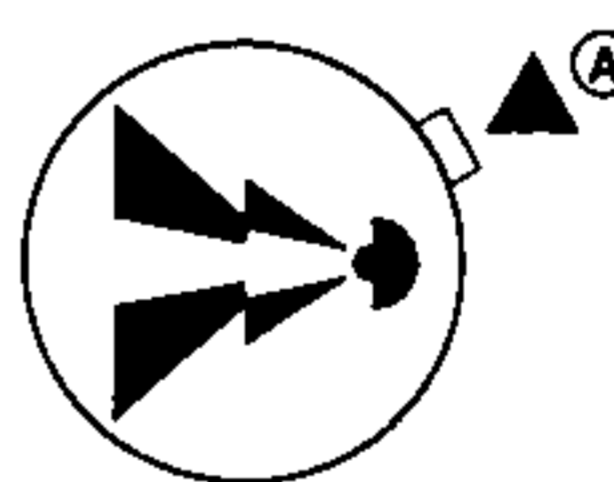

- Sound can be monitored by pressing (A) button when the local time alarm is ON or OFF.



## Setting procedures

Push the **(M)** button in to the normal position

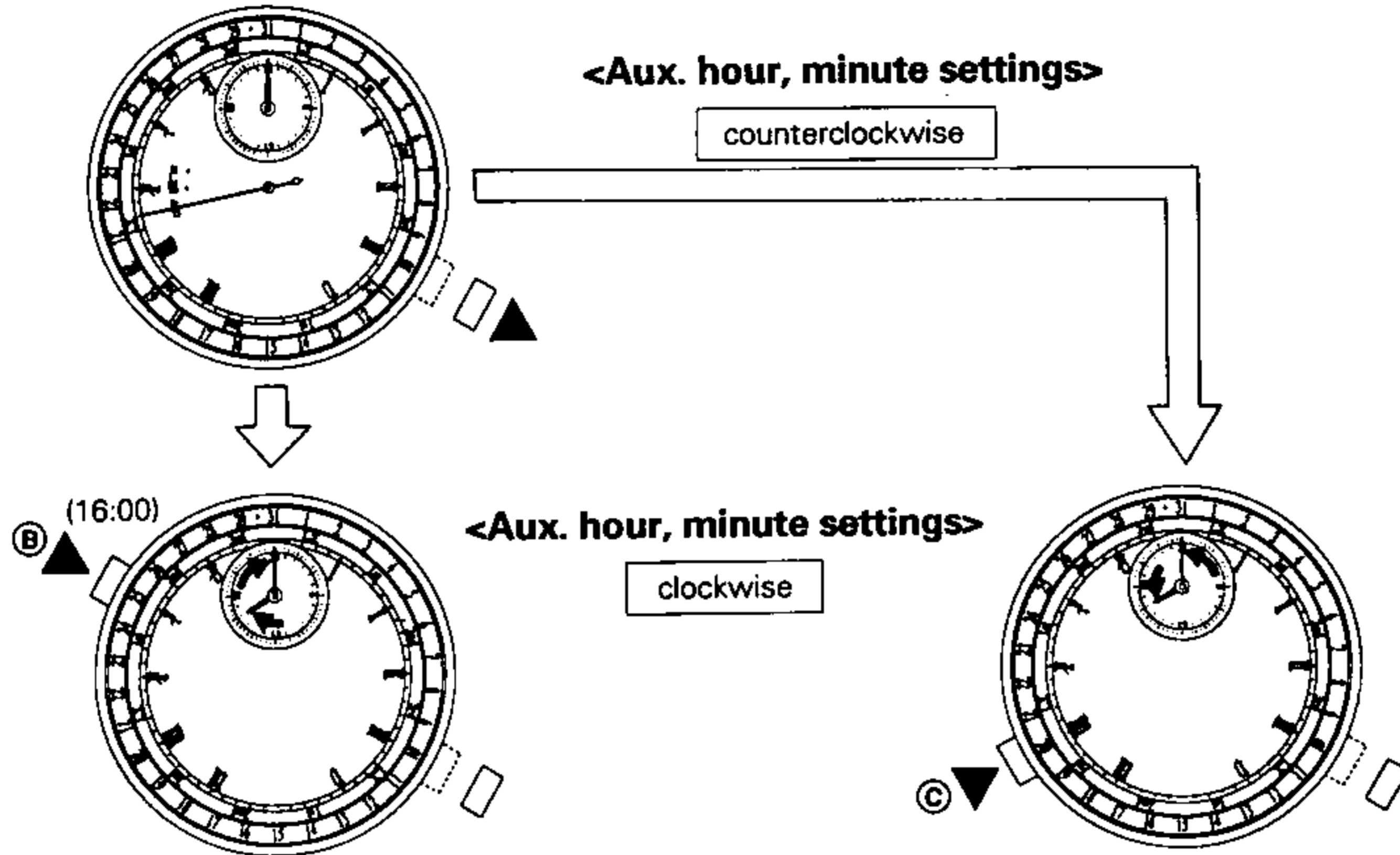

- Hour and minute hands display the local time.
- Press and hold down either the **(B)** or **(C)** button to use the quick-advance feature.
- Auxiliary hour and minute hand movement is about twice as fast after the first revolution (clockwise movement only.)

## Alarm auto ON function Alarm sound selector

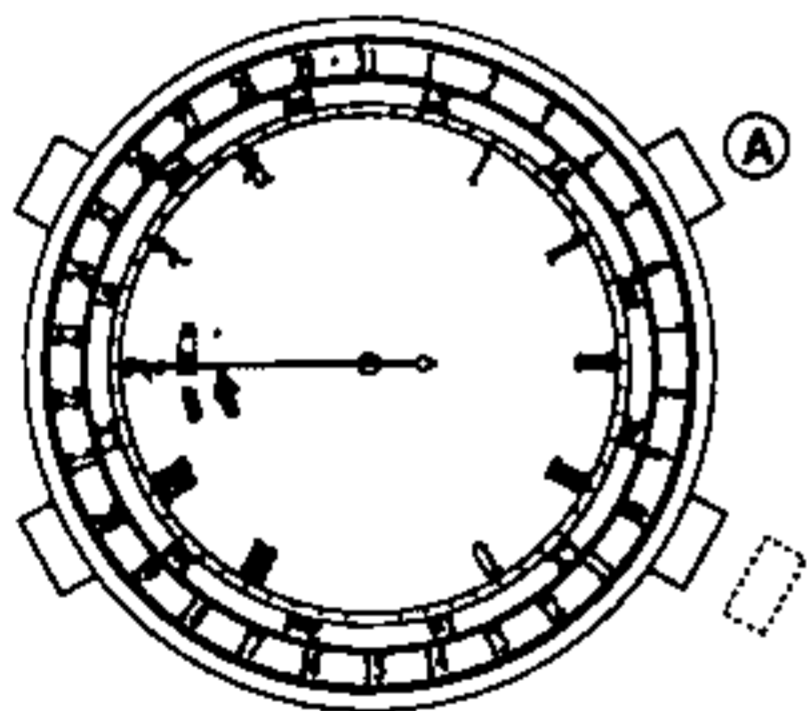

Push the **(M)** button in to the normal position  
Alarm setting is complete

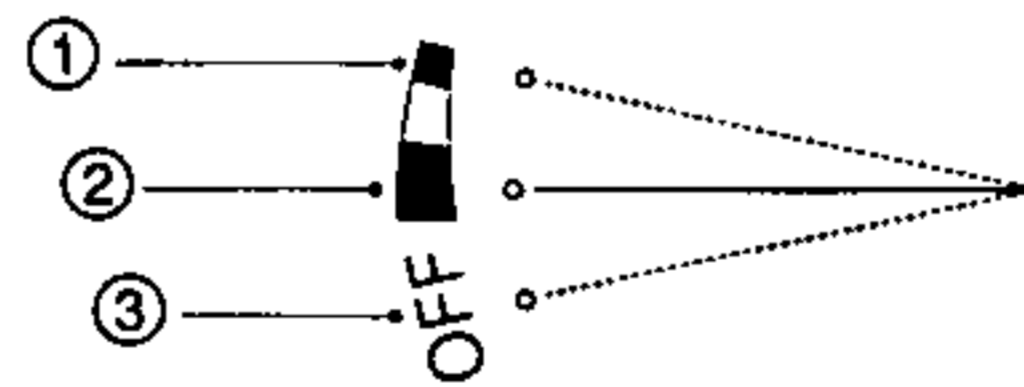
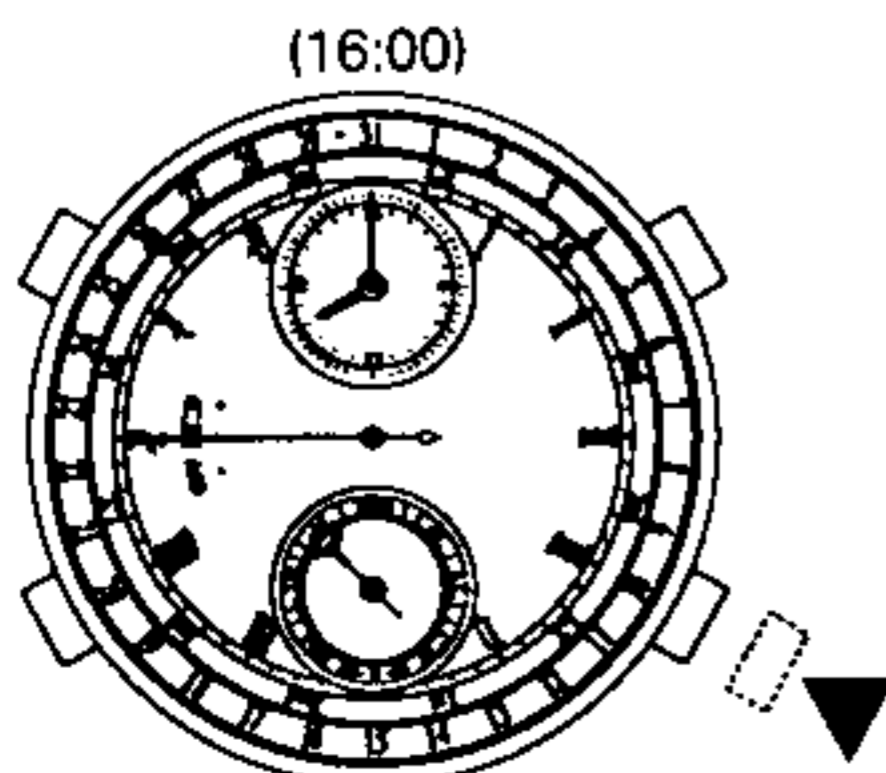

- Pull the **(M)** button out to the first step, the second hand moves to position 2 and the alarm is turned ON.
- Press the **(A)** button to adjust the sound between soft/loud. (The level of the alarm sound in position ① is softer than position ②.)



## 9. MONITORING IN THE NORMAL TIME MODE

### a. Calendar Monitor

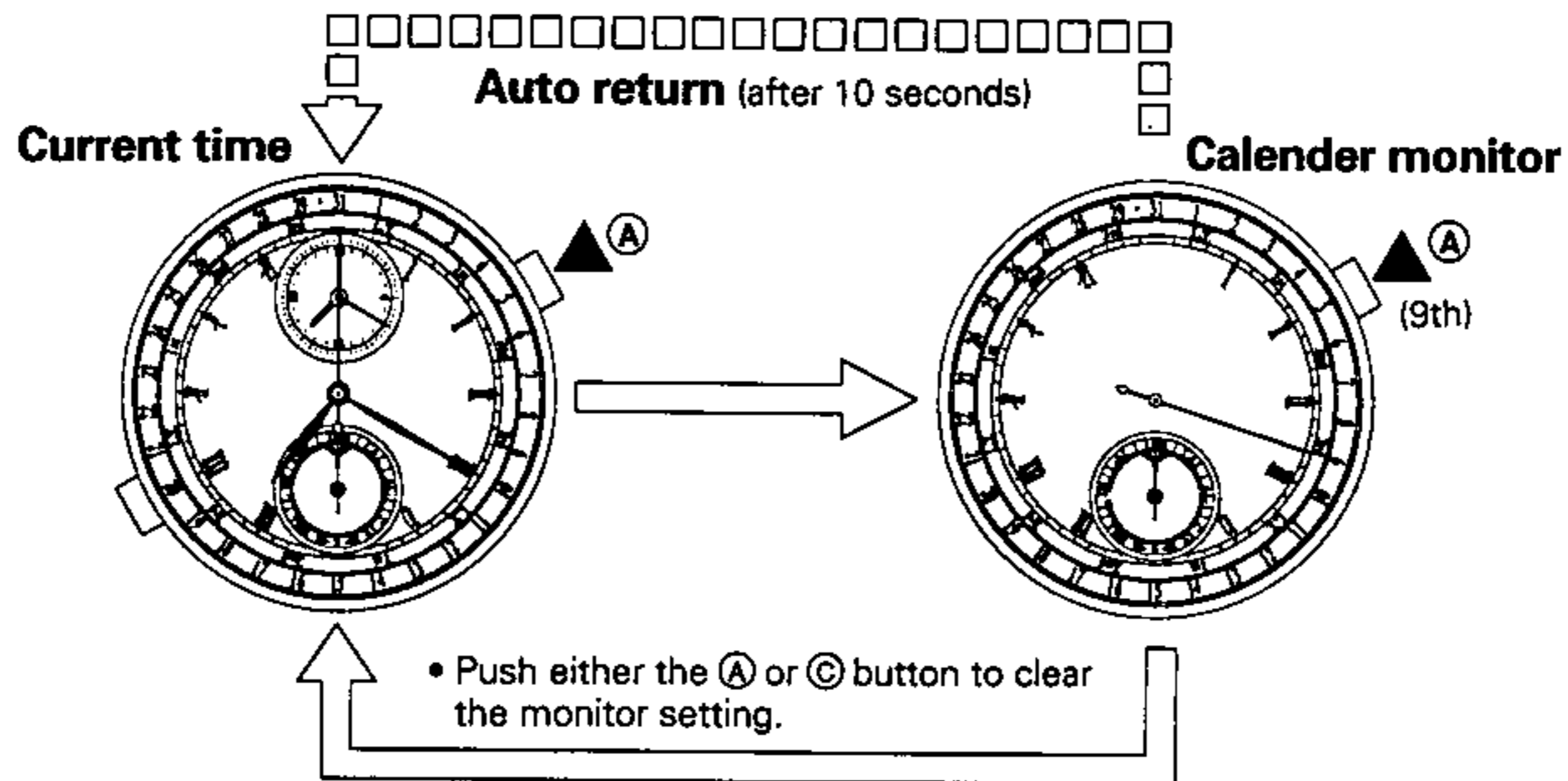

☆ Second hand displays the date. The leap years and months are not displayed.

### b. Daily alarm (AL-2) Set Monitor

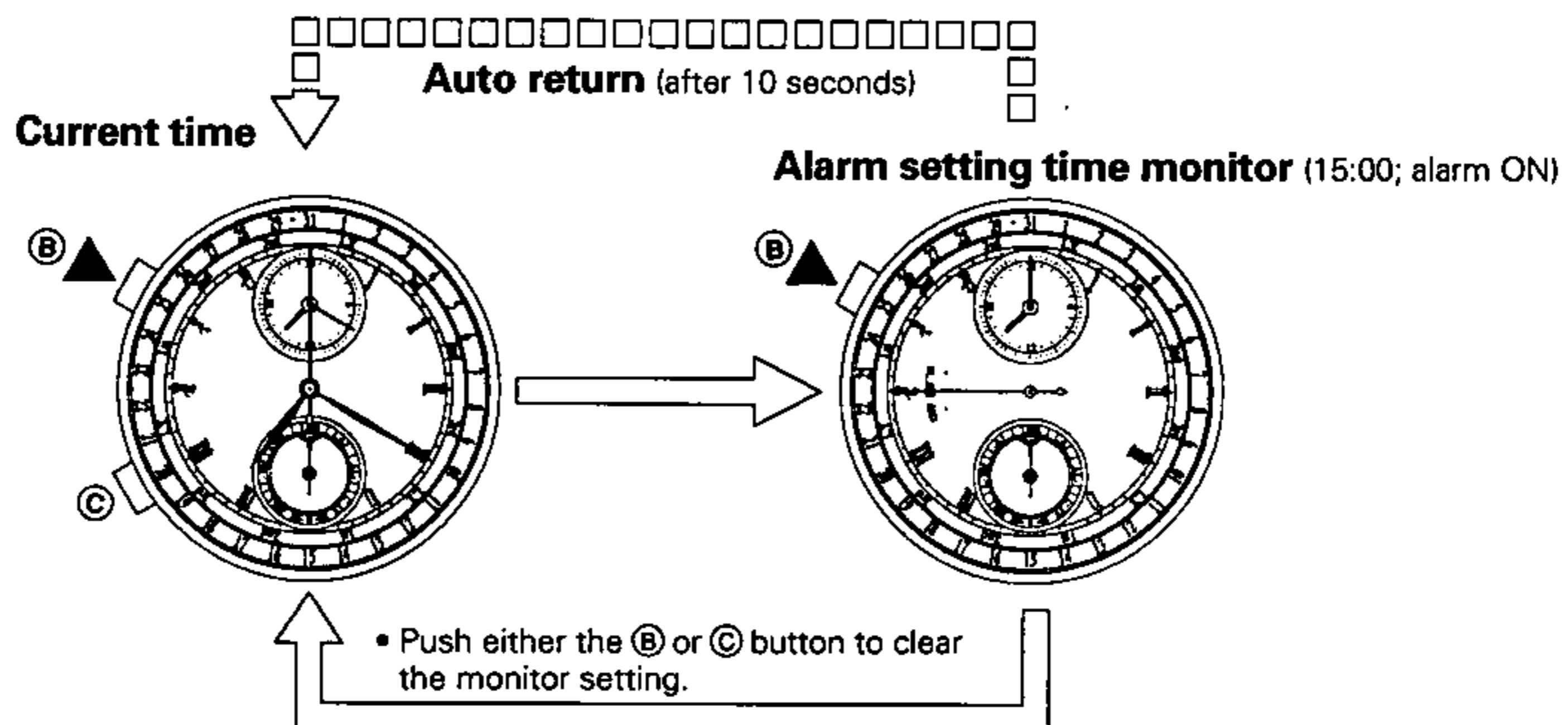

- ☆ Press the (B) button while monitoring the calendar to monitor the alarm (AL-2) settings.
- ☆ Press the (A) button while monitoring the alarm (AL-2) settings to monitor the calendar setting.
- ☆ Both of the above monitor modes return automatically (auto return) to the current time after 10 seconds.



## 10. MONITORING IN THE LOCAL TIME MODE

### Local time alarm Monitor

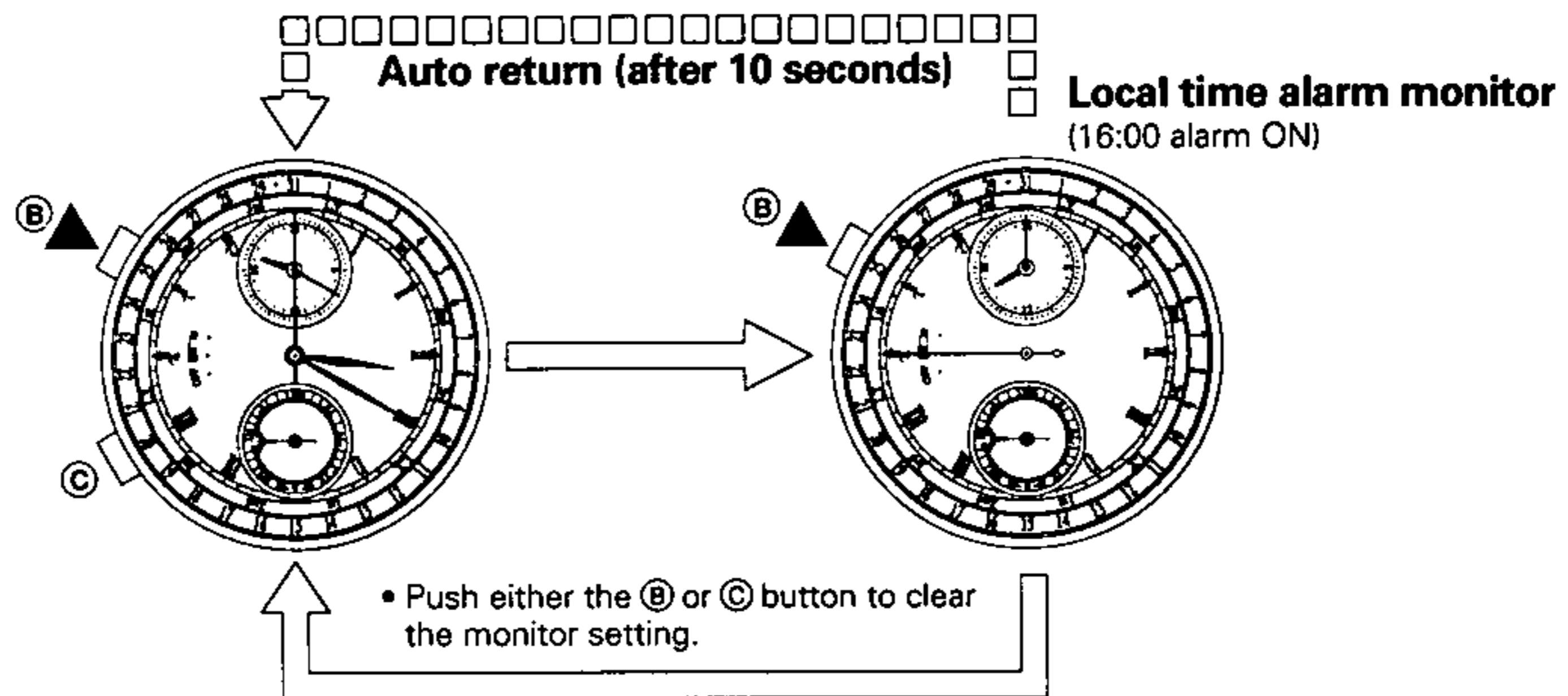

- Displayed by aux. hour, minute and second hands.

## 11. ALL RESET FUNCTION

The all reset function is used following battery replacement of abnormal watch movement.

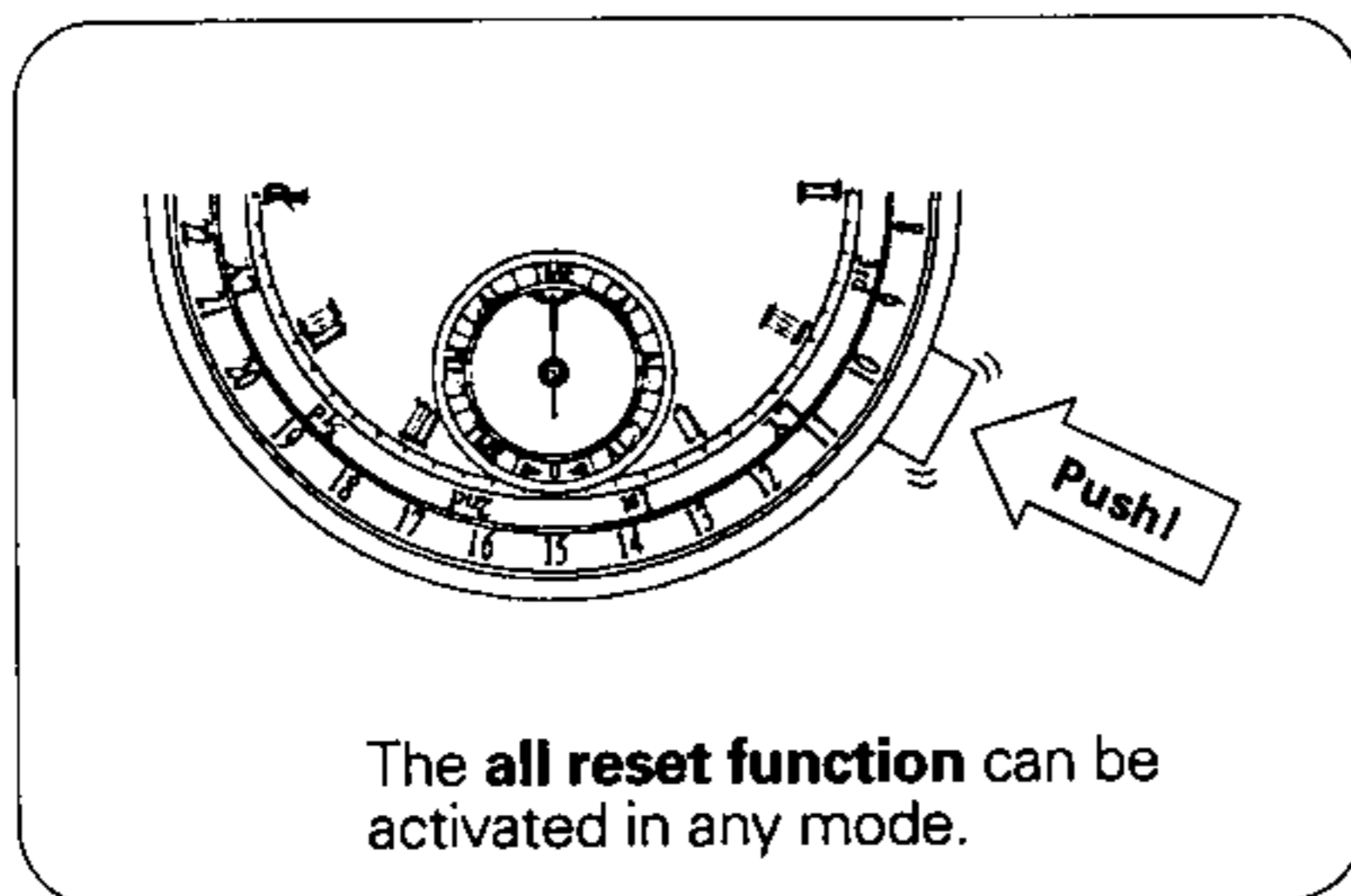

### All reset procedure

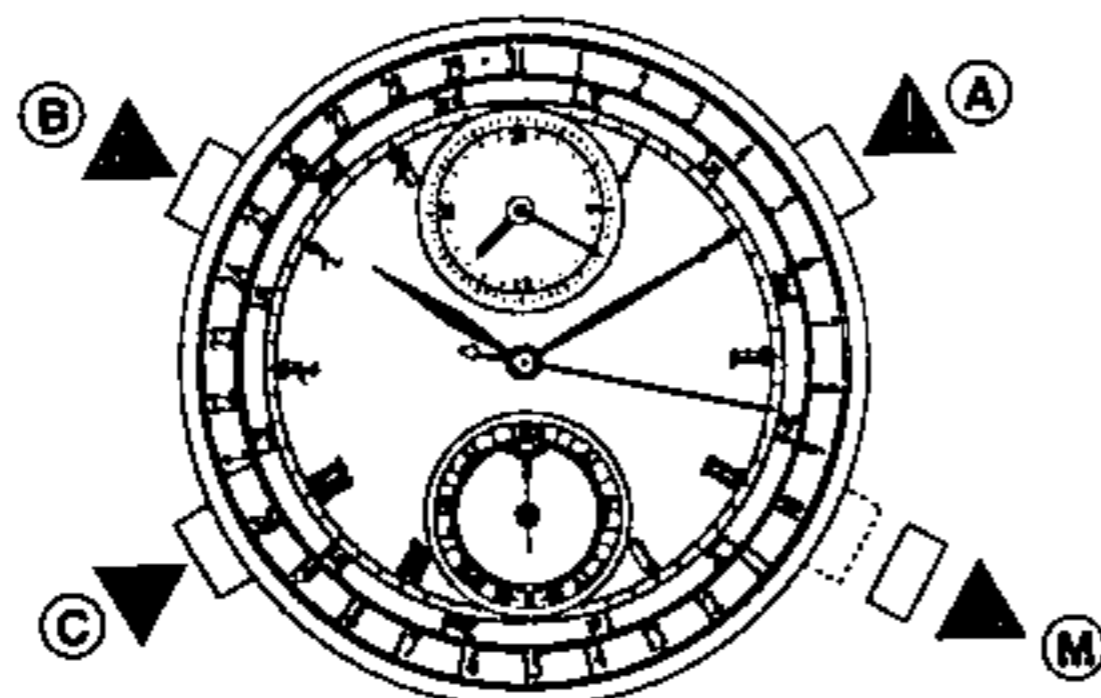

1. Pull the (M) button out to the first step.
2. Push and hold down the (A), (B), (C) buttons simultaneously for more than 2 seconds.
3. Release all three buttons and a confirmation beep will sound and the minute, auxiliary minute and second hands will move slightly. Push the (M) button in to the normal position after the above procedures have been completed and then **set the watch to 0**. (See **BEFORE USE: "Zero position setting"** and then reset the time.)

## 3-2 OPERATING METHOD CAL 6850

### §1 MAIN COMPONENTS

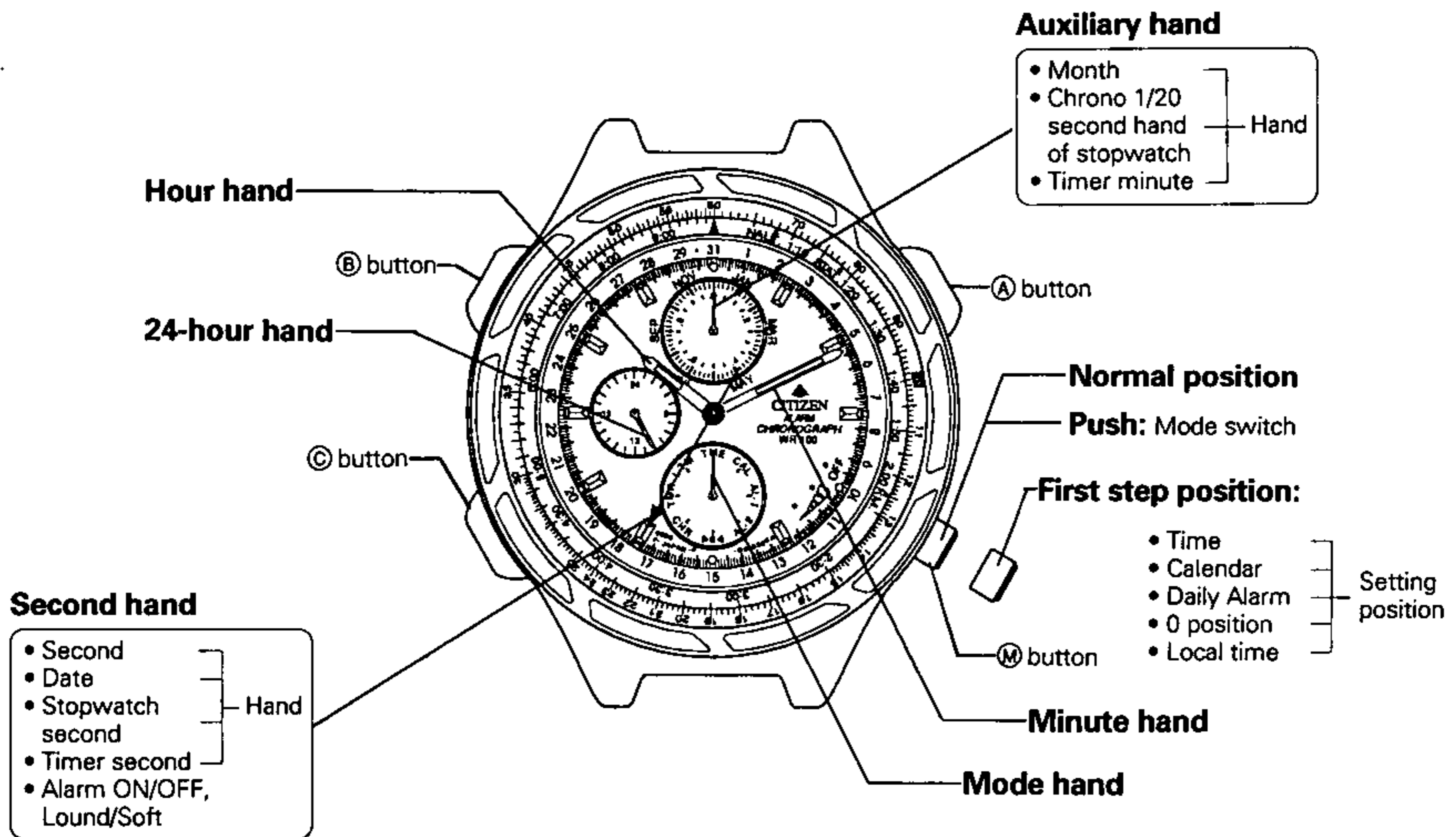

• ○ indicates functions of main watch hand.

### §2 MODE CHANGE-OVER

Push the (M) button in the normal position to switch between modes as shown below.

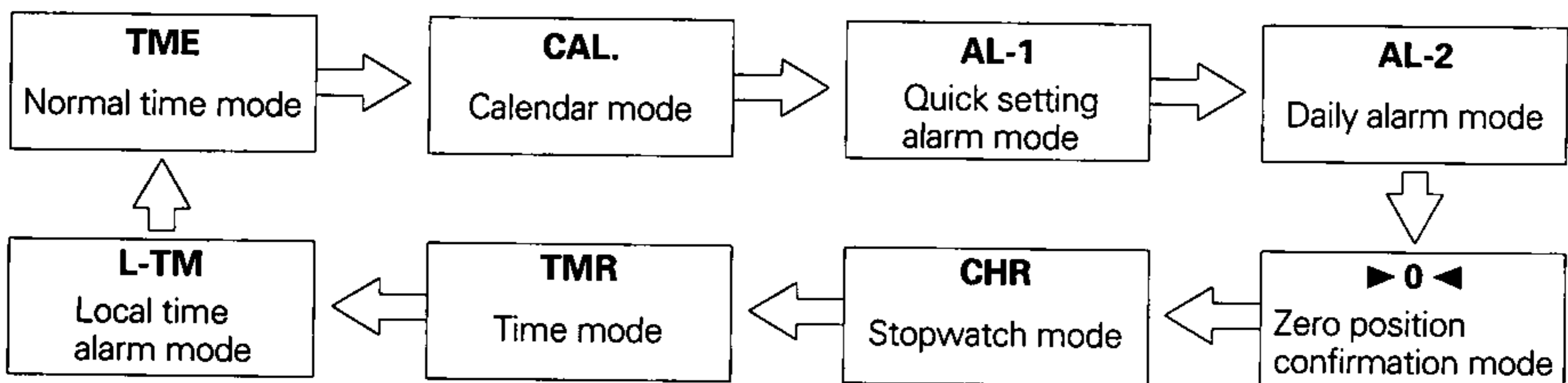

#### Note:

Always check the mode hand to ensure the watch is set in the desired mode during use, since pressing the (M) button unknowingly during operation may occur.

### §3 BEFORE USE

Before use, follow the procedures below to ensure that all watch components are in proper working order:  
**Confirm the Zero position setting.**

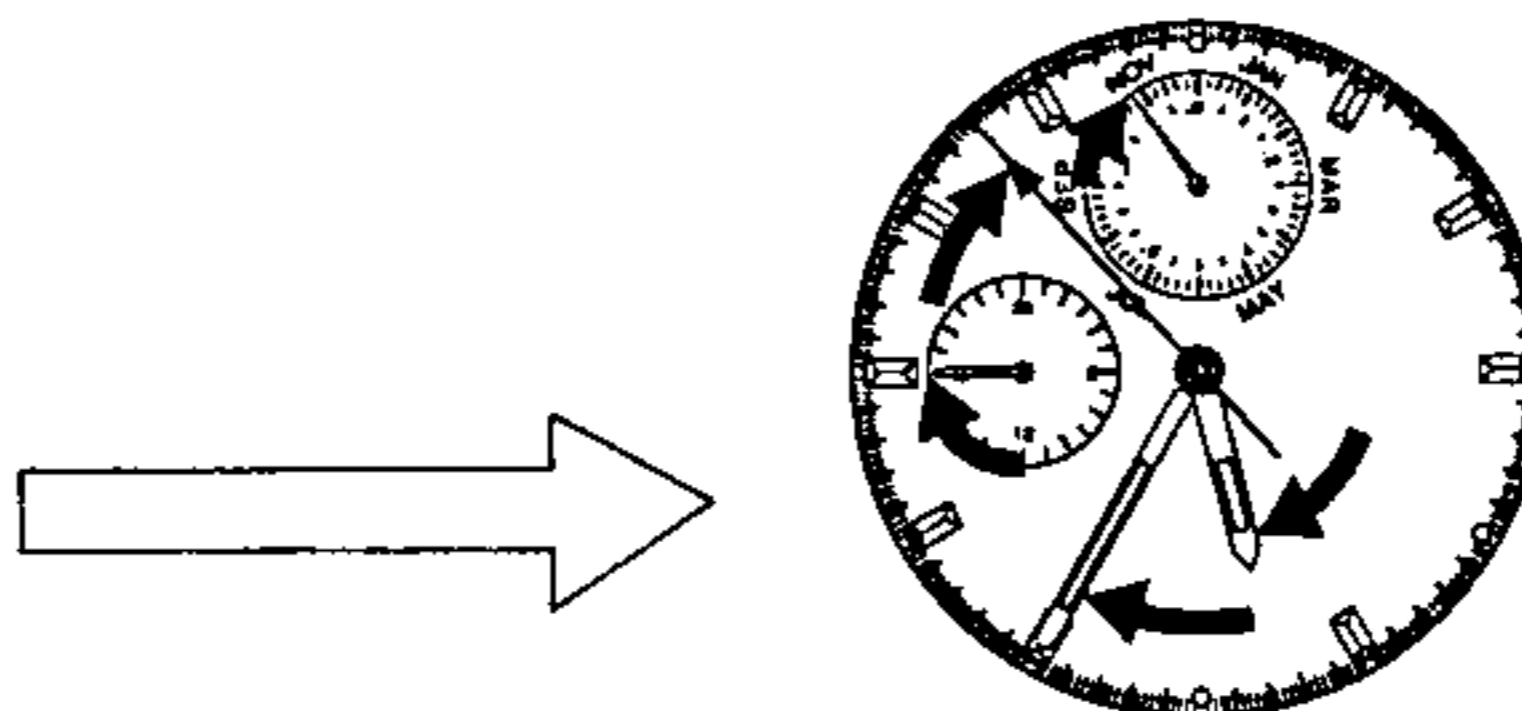
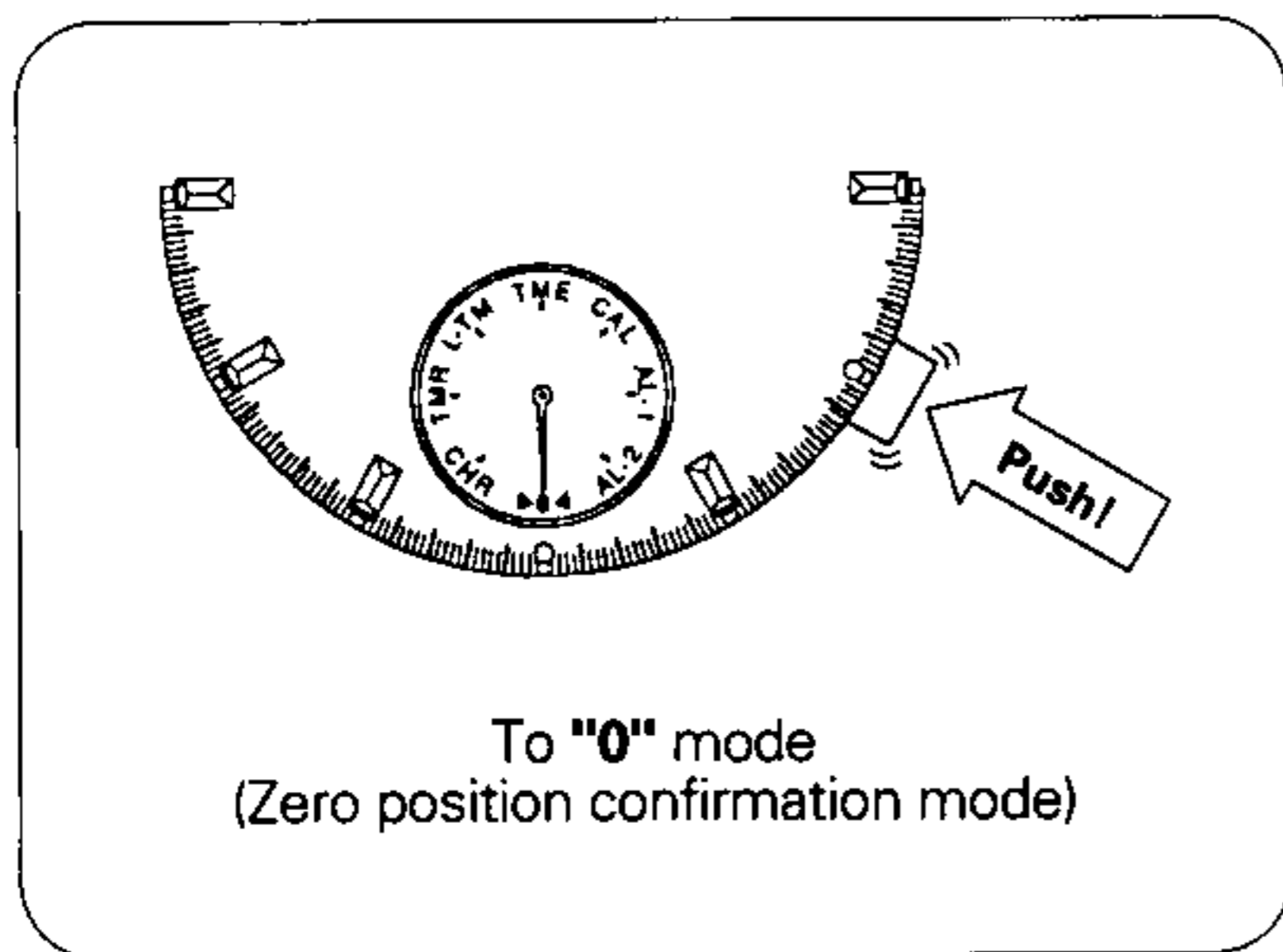

- All hands, except the mode hand, move to the "0" position.
- The 24-hour hand is synchronized with the hour/minute hands.

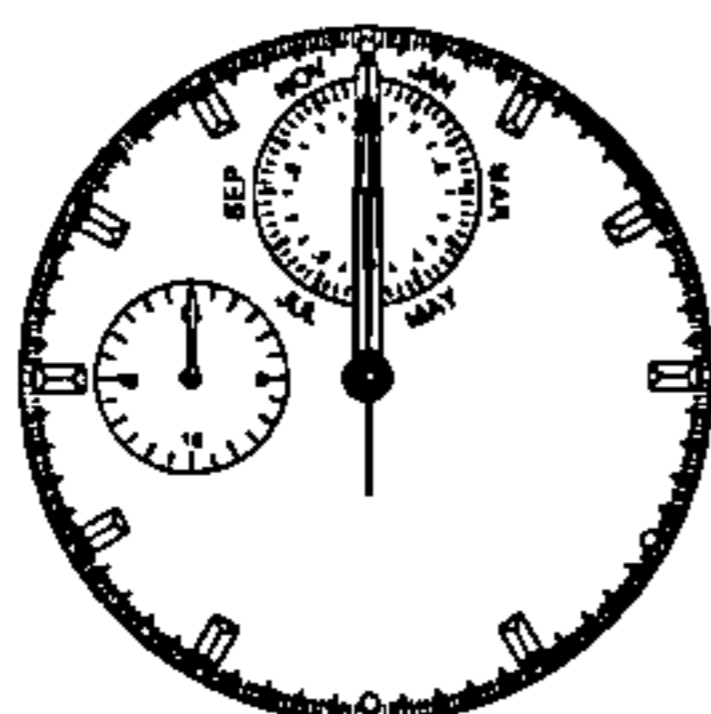

Each hand positioned as listed below confirms the "0" position setting correct.

<b>Hour hand</b> .....	0 hr.	} <b>position</b>
<b>Minute hand</b> .....	0 min.	
<b>Second hand</b> .....	0 sec.	
<b>24-hour hand</b> .....	0 hr.	
<b>Auxiliary hand</b> .....	0 min.	

If the watch hands are not positioned as above, follow the **Zero position setting** procedures to ensure proper use.

### ZERO POSITION SETTING

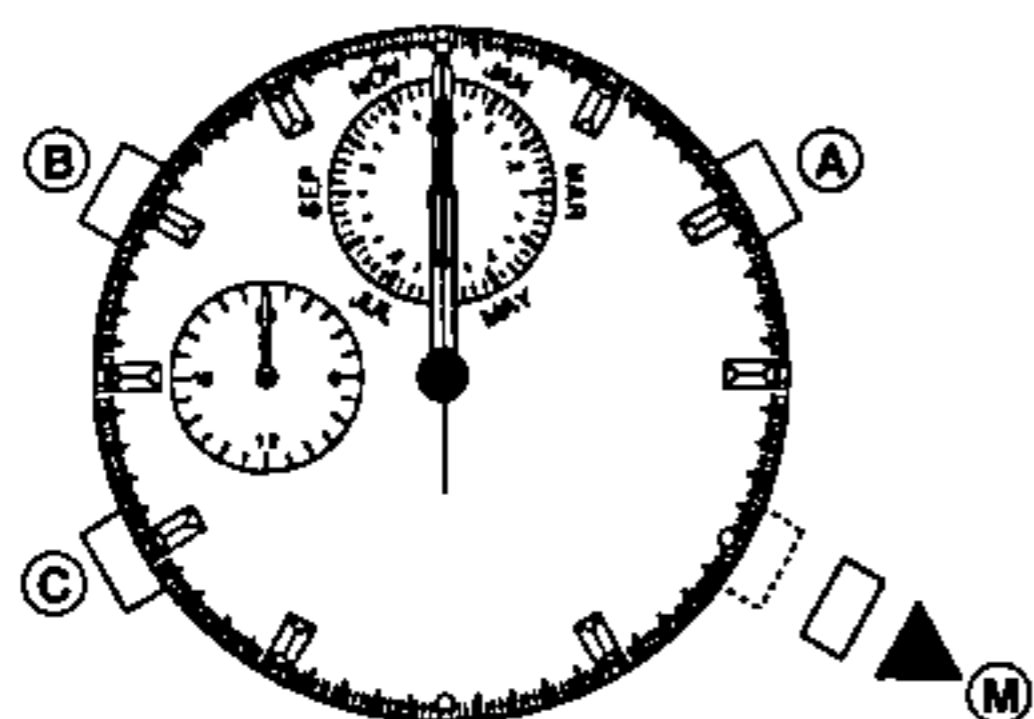

- 1) Pull the (M) button out to the first step position.  
 Push the (A) button to set the second hand to the 0 sec. position.  
 Push the (B) button to set the Aux. feature hand to the 0 hour position.  
 Push the (C) button to set the hour/minute/24-hour hands to the 0 hour, 0 minute position.
  - 2) Be sure to push the (M) button in to its normal position. This completes the **Zero position setting**.
- ☆ Press and hold down any of the (A), (B), (C) buttons to activate the quick-advance feature.
  - ☆ A strong shock may cause hands to move from the zero position. In this case, reset to the correct zero position.

## §4 HOW TO SET AND OPERATE EACH MODE

### 1. HAND MOVEMENT DEMONSTRATION

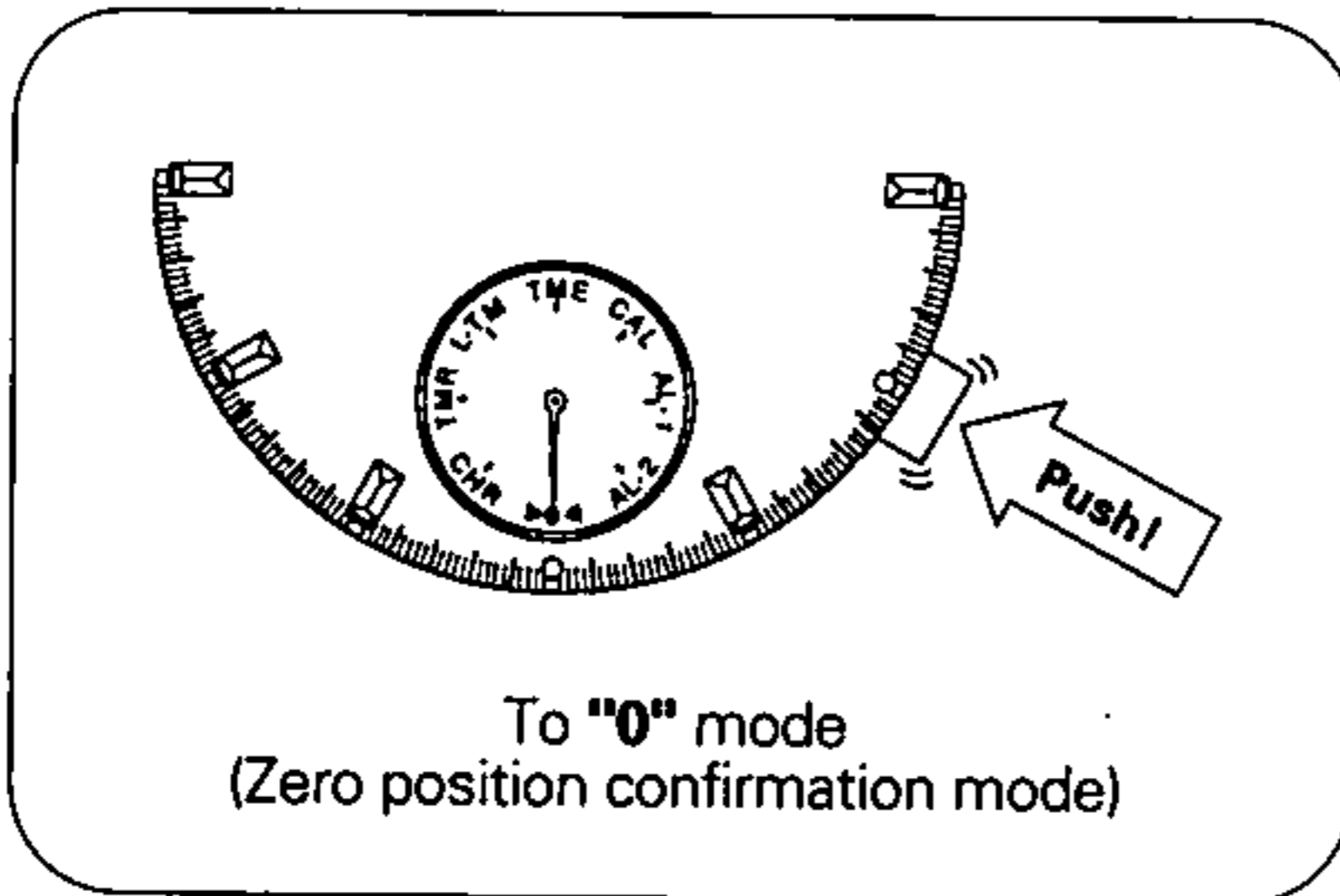

Pushing and of the (A), (B) and (C) buttons once will cause the second, minute and auxiliary feature hands to stop in the "0" position after moving through the following stages.

- **Minute hand:** ① +5 min. → ② -10 min. → ③ +5 min.
- **Second hand:** ① +5 sec. → ② -10 sec. → ③ +5 sec.
- **Aux. hand:** ① +5 → ② -10 → ③ +5

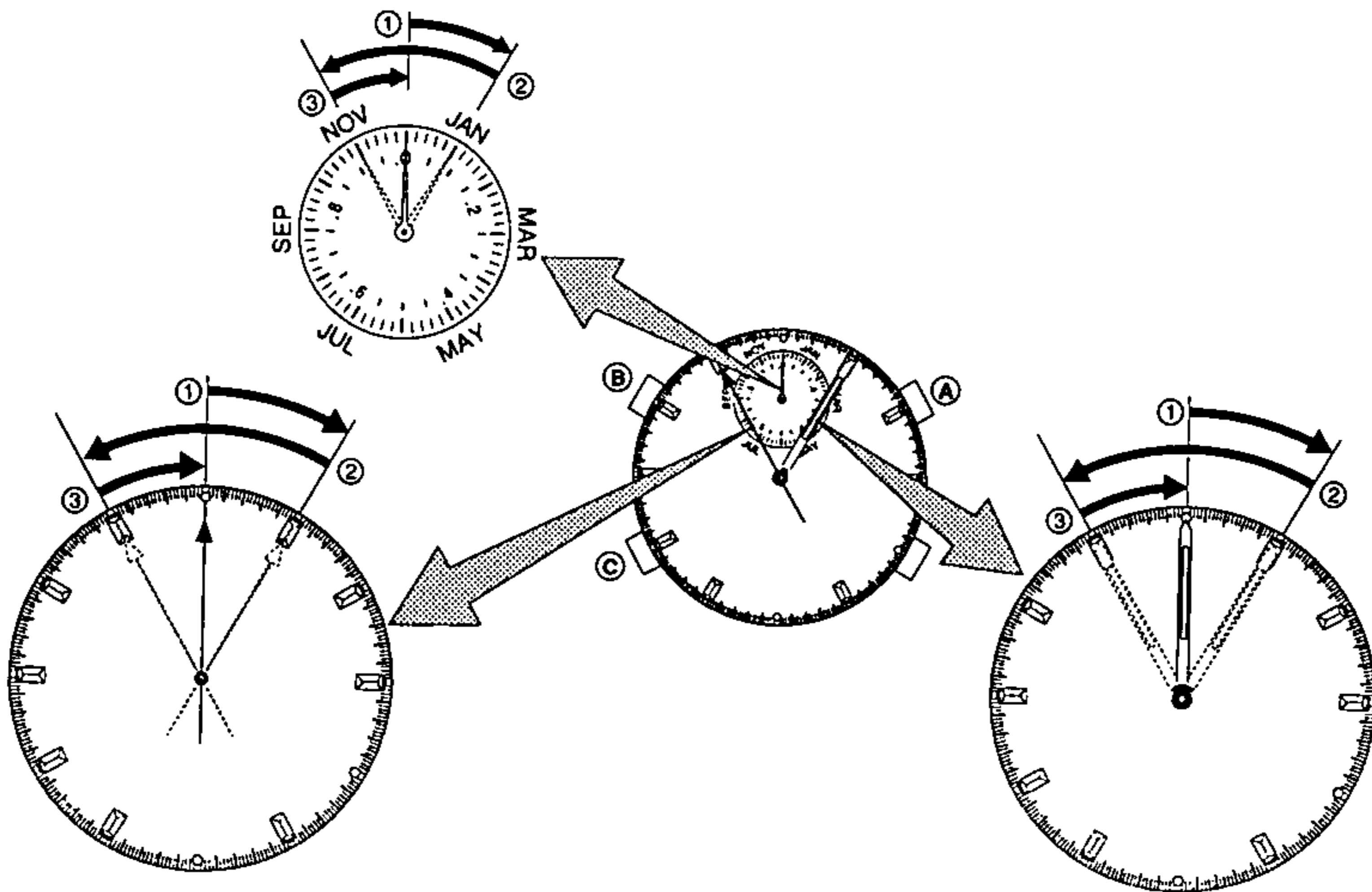

## 2. SETTING THE TIME

Changing the time from 10:10.15 to 19:20.00

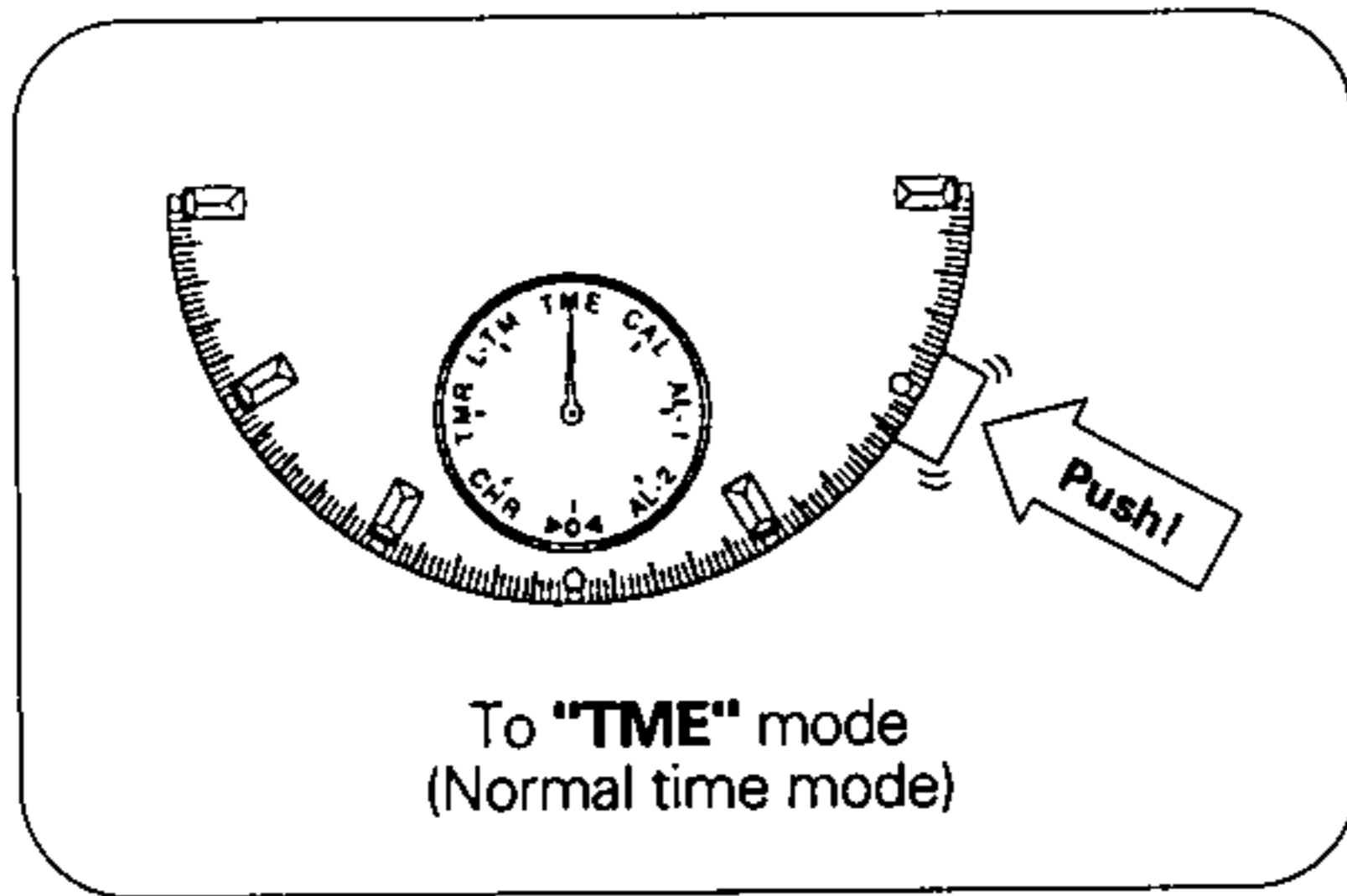

<M button in the normal position>

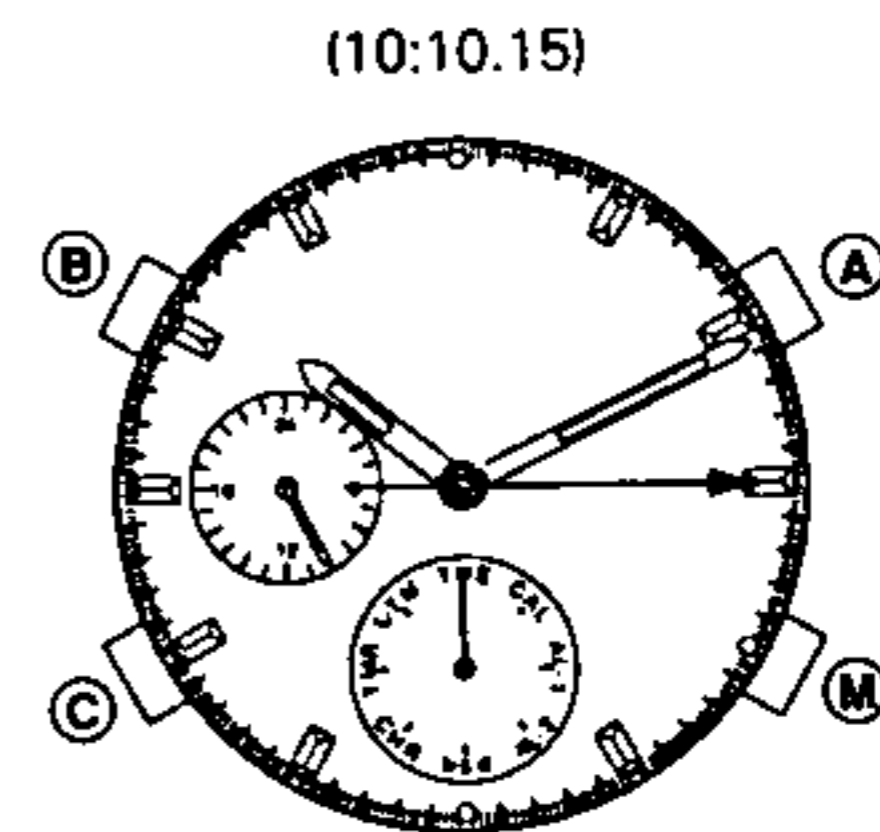

- The hour/minute hand is based on the 12-hour clock system. Use the 24-hour hands as a reference under normal time setting procedures to determine morning/afternoon times.

### Setting procedures

<M button: 1st step position>

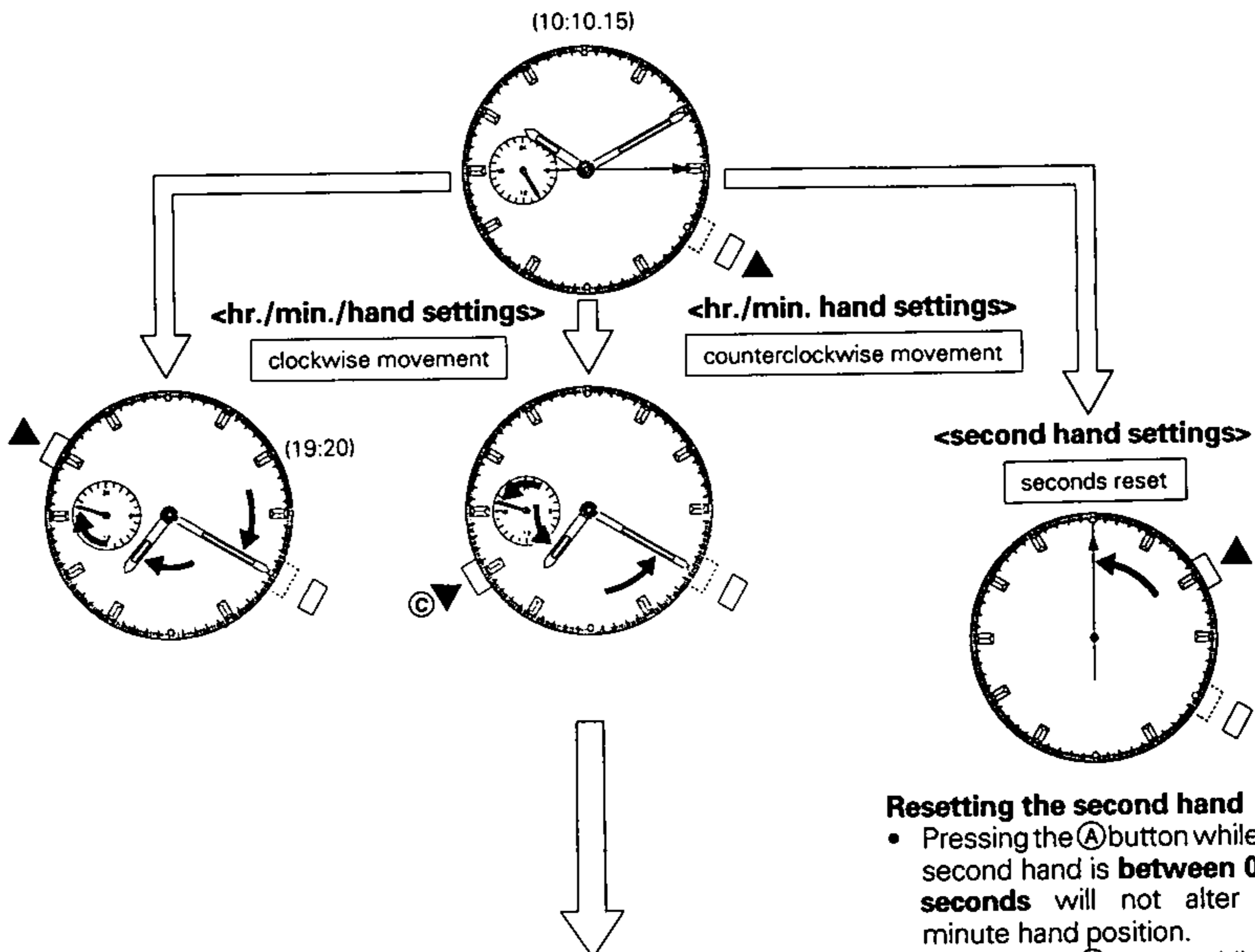

#### Resetting the second hand

- Pressing the A button while the second hand is **between 0–29 seconds** will not alter the minute hand position.
- Pressing the A button while the second hand is **between 30–59 seconds** will advance the minute hand to the next full minute position.



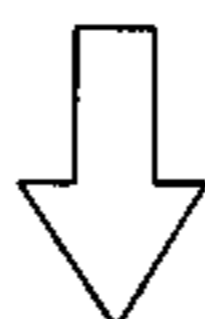

Push the **(M)** button in to the normal position

Time setting complete at 19:20.00

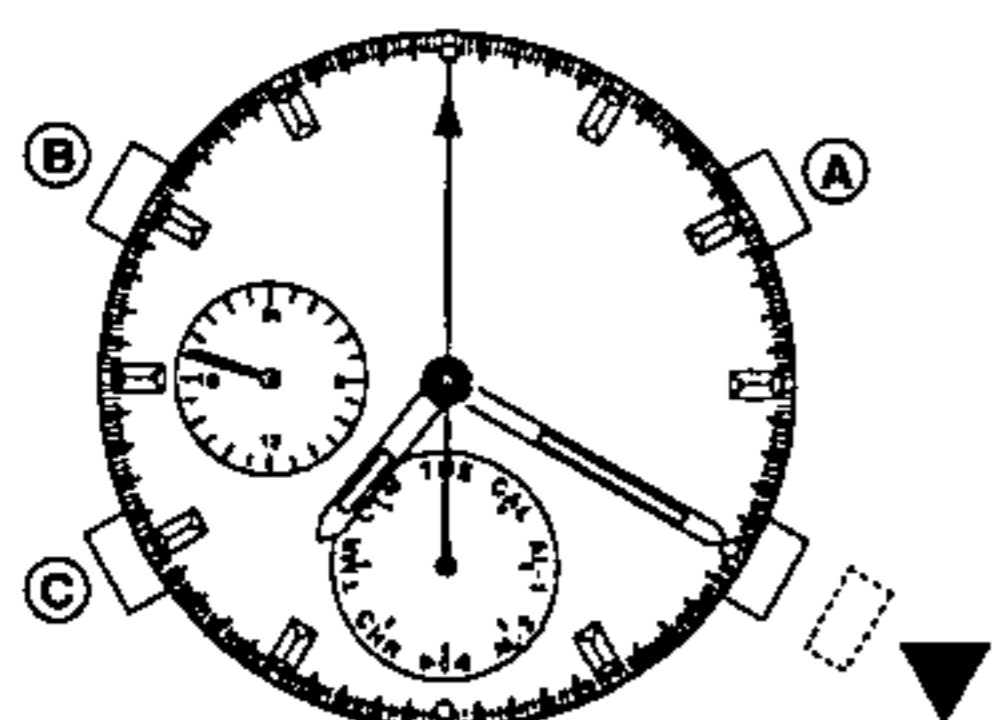

- ☆ Press and hold down either the **(B)** or **(C)** button to use the quick-advance feature.
- ☆ Quick-advance function: Hand movement is about twice as fast after the first revolution. (clockwise movement only).
- ☆ The hour/minute/24-hour hands are synchronized.

### 3. SETTING THE CALENDAR (CAL)

Changing the calendar from May 5 to Sep. 9.

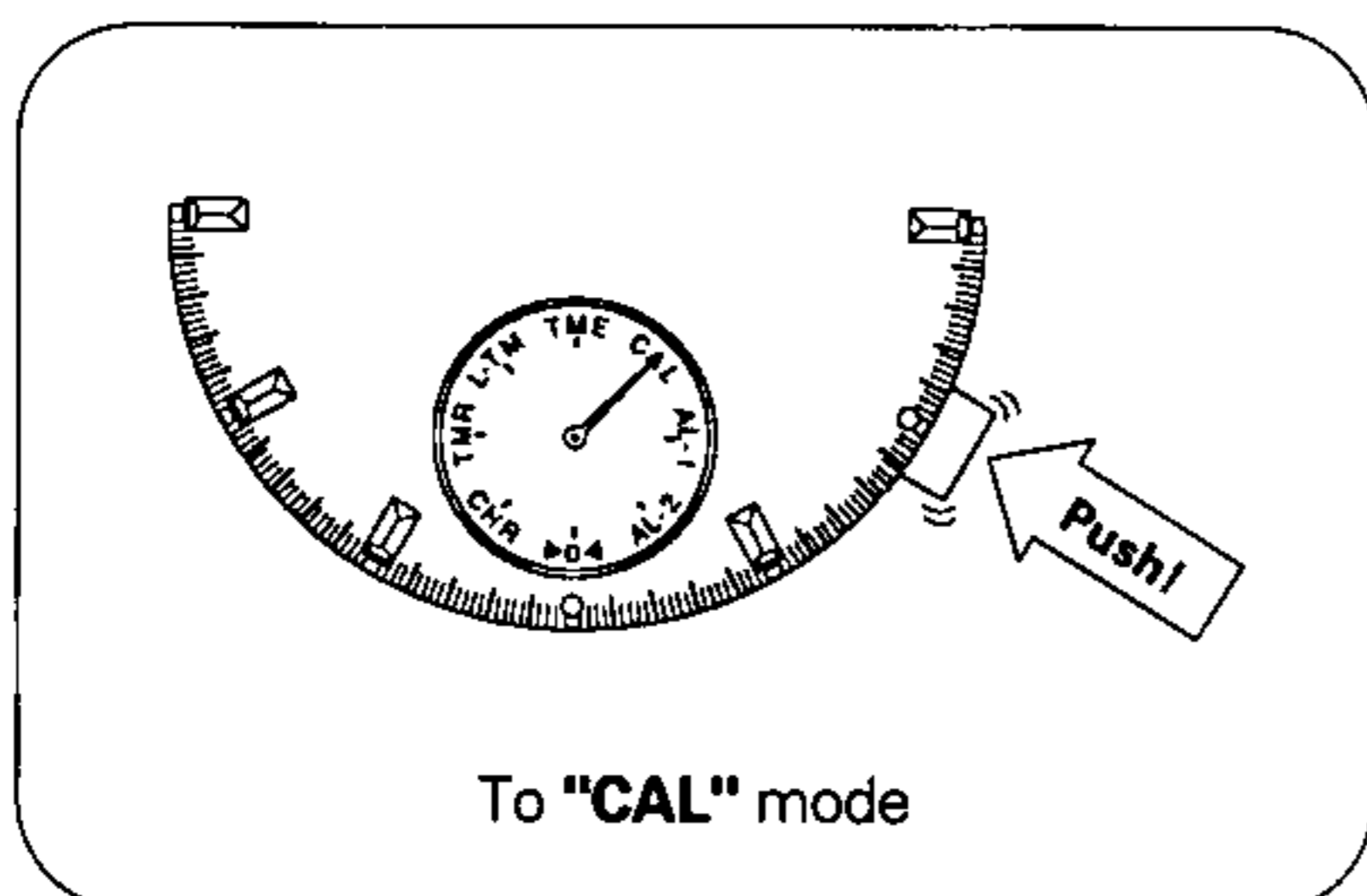

#### Automatic calendar system

The calendar feature on this watch requires no adjustment at the end of the month. Adjusted for Feb. 29 during a leap year.

<**(M)** button normal position>

(May 5)

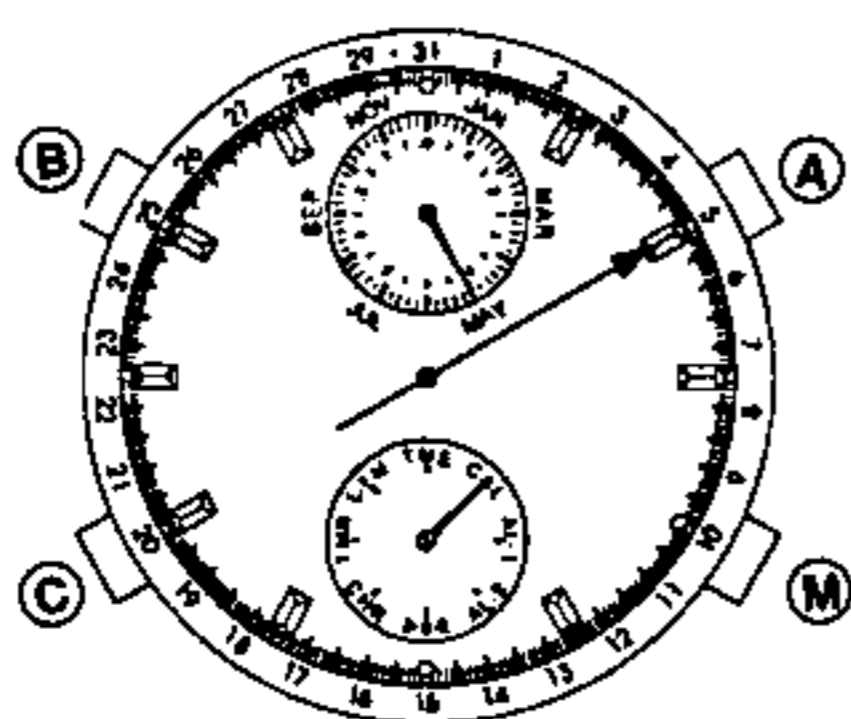



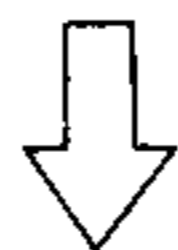

## Setting procedures

- ☆ Press and hold down either the (A) or (B) button for the quick-advance feature.
- ☆ The month and date must be independently set.

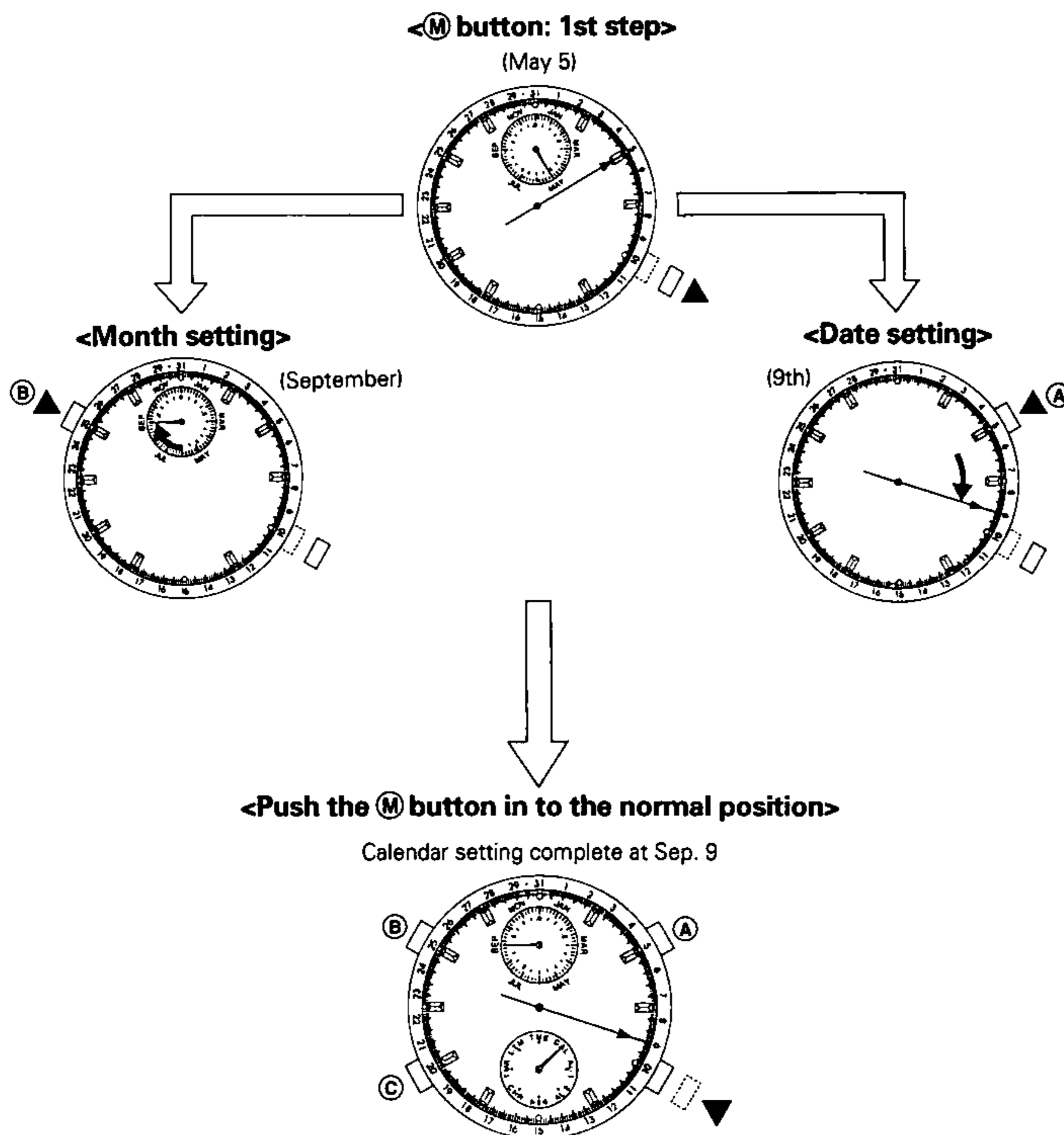

### Automatic calendar correction system

When a nonexistent date is entered, the watch will automatically set the date to the 1st of the following month when the (M) button is pushed in to the normal position.  
**(Forexample: Feb 30 → March 1st)**

#### 4. SETTING THE QUICK-SET ALARM (AL-1)

Setting the alarm to ring 50 minutes from the current time, 19:20, at 20:10.

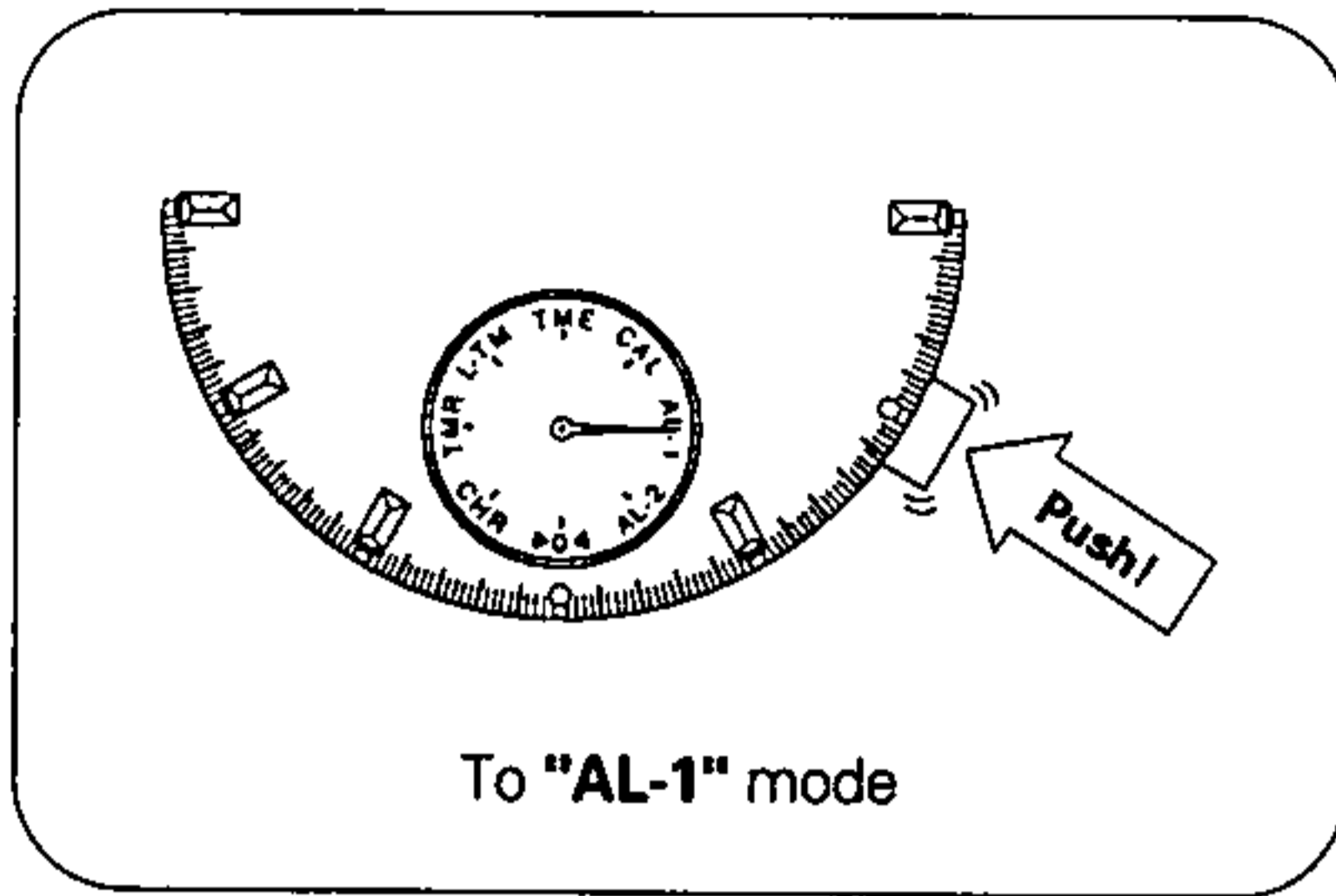

#### Quick-set alarm function

When the alarm is OFF the hr./min./sec./24-hour hands display the current time. This feature allows the alarm to be easily set to the desired time within the 23 hour 59 minute maximum limit. **Following one ring of the alarm (10 seconds) the alarm setting is automatically cleared from memory and the auxiliary time display returns to the current time.**

Alarm can be set in this position

Ⓜ button normal position

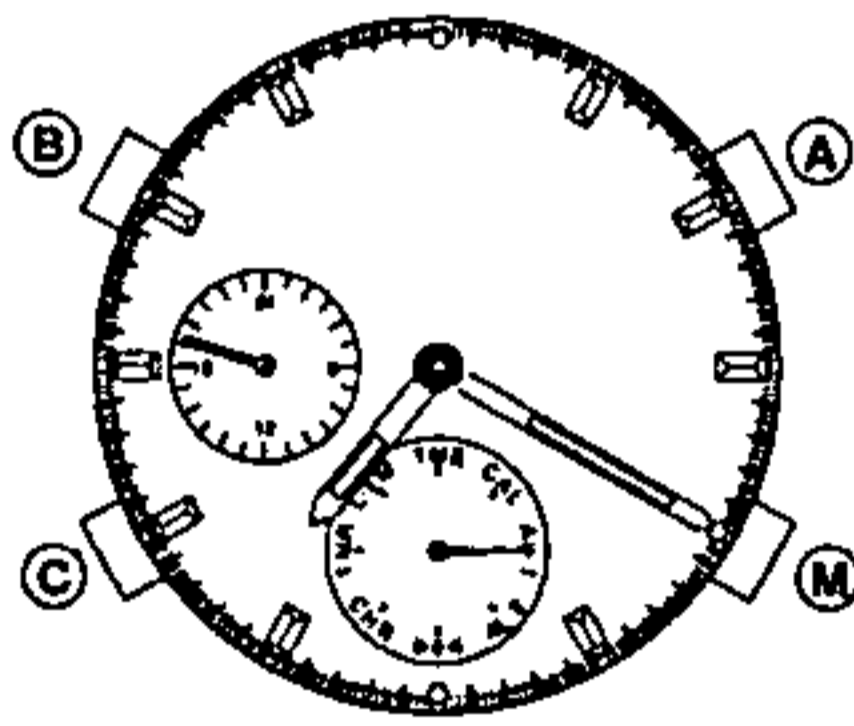

<Sound monitor>

(5 seconds)

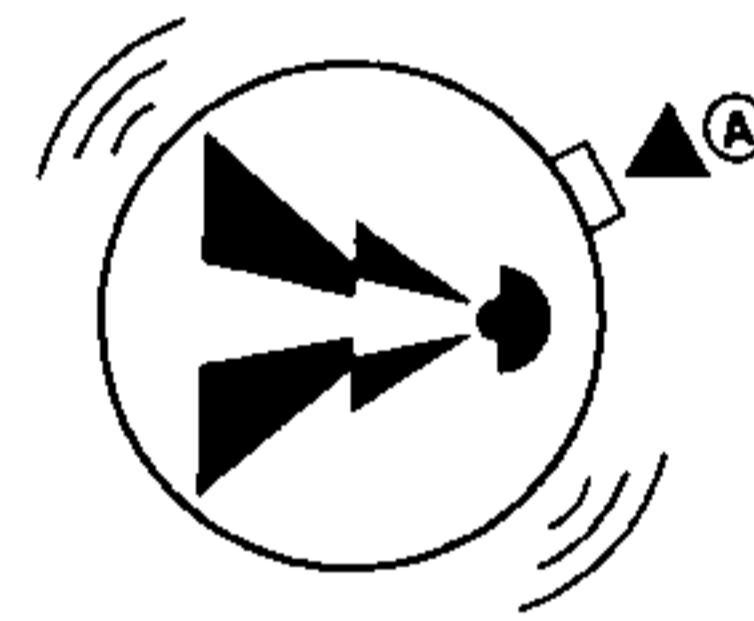

- Push the ⓐ button when the quick set alarm is OFF.

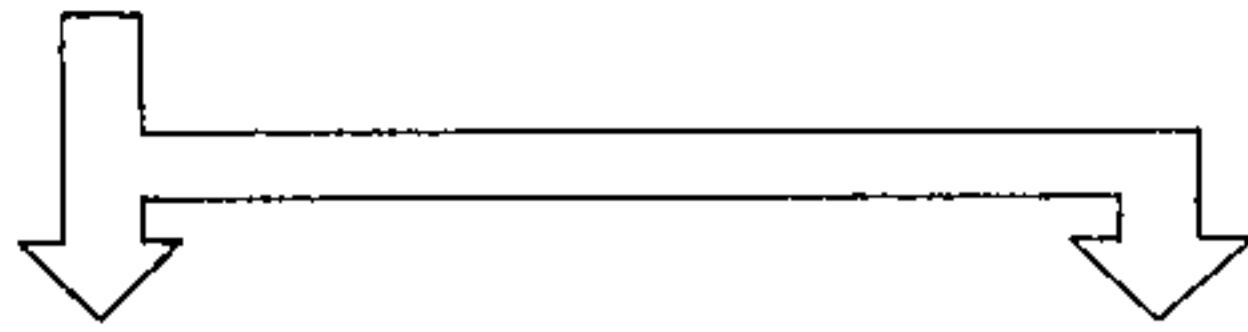

## Setting procedures

### <Hour/minute setting>

clockwise

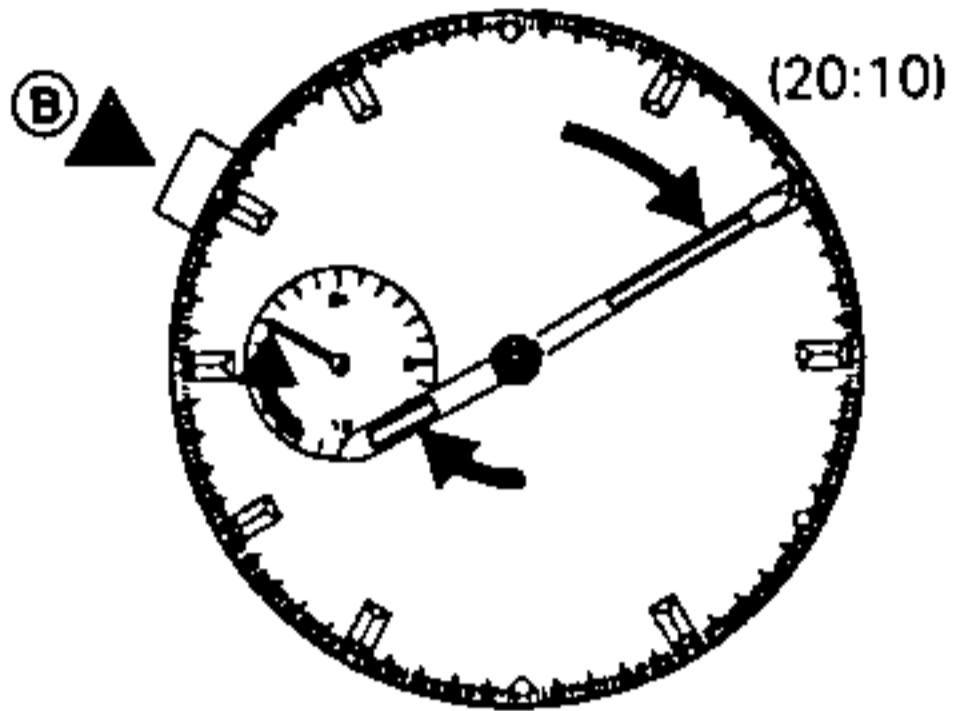

### <Hour/minute setting>

counterclockwise

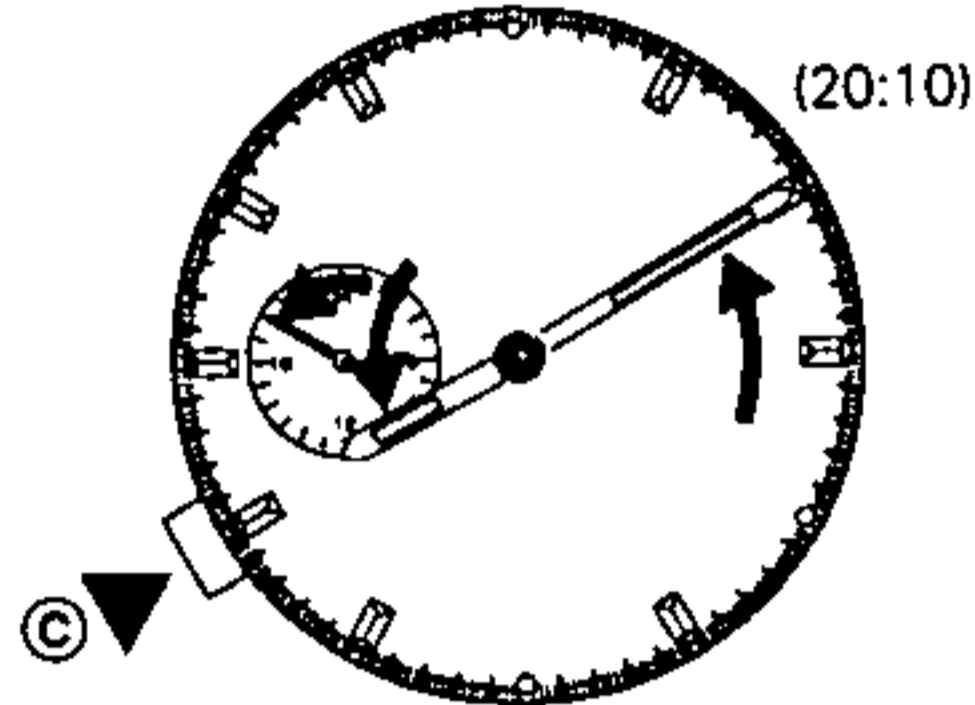

### <Quick-set alarm auto ON function>

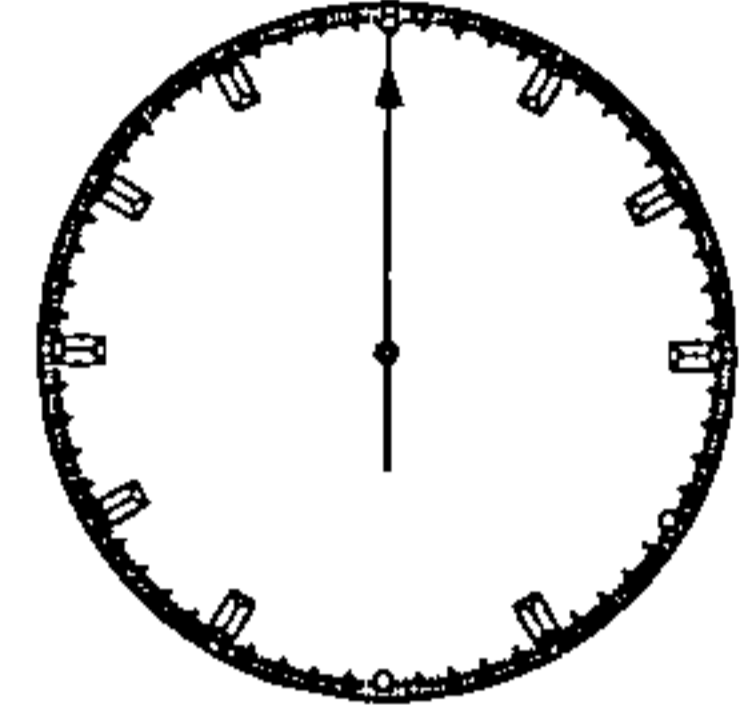

**Alarm ON:** second hand stops in the "0" position.

**Alarm OFF:** Hr./min./sec./24-hour hands display the current time.

- ☆ Press and hold down either the (B) or (C) button for the quick-advance feature.
- ☆ Quick advance function: Hand movement is about twice as fast after the first revolution (clockwise movement only).
- ☆ The hour/minute/24-hour hands are synchronized.

After adjusting the hour and minutes, the second hand returns to the "0" position and stops. **The alarm is now ON.**

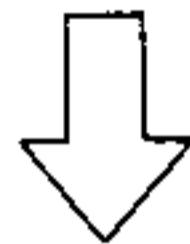

### <Alarm quick-set is complete>

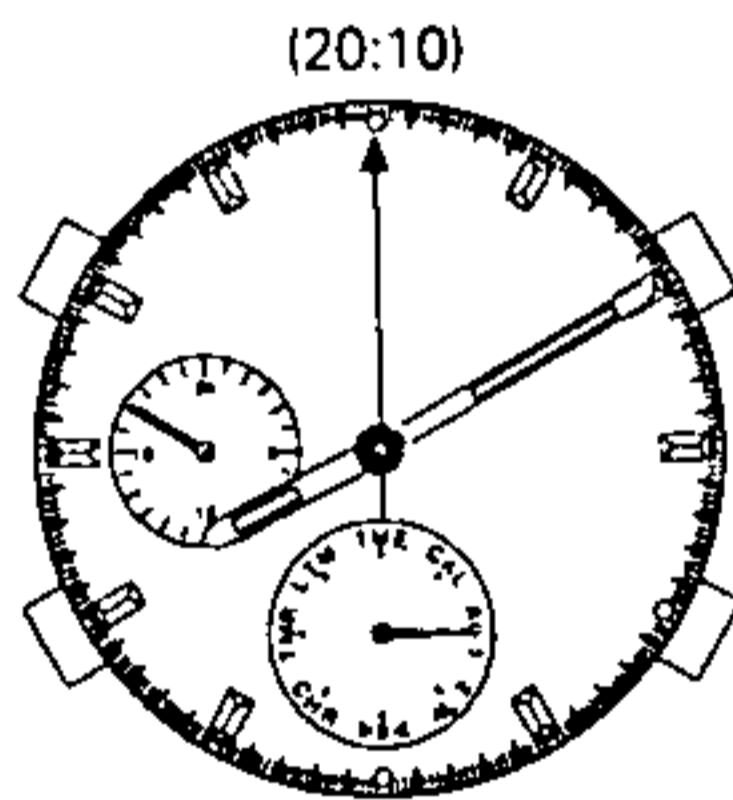

### <Canceling the quick-set alarm>

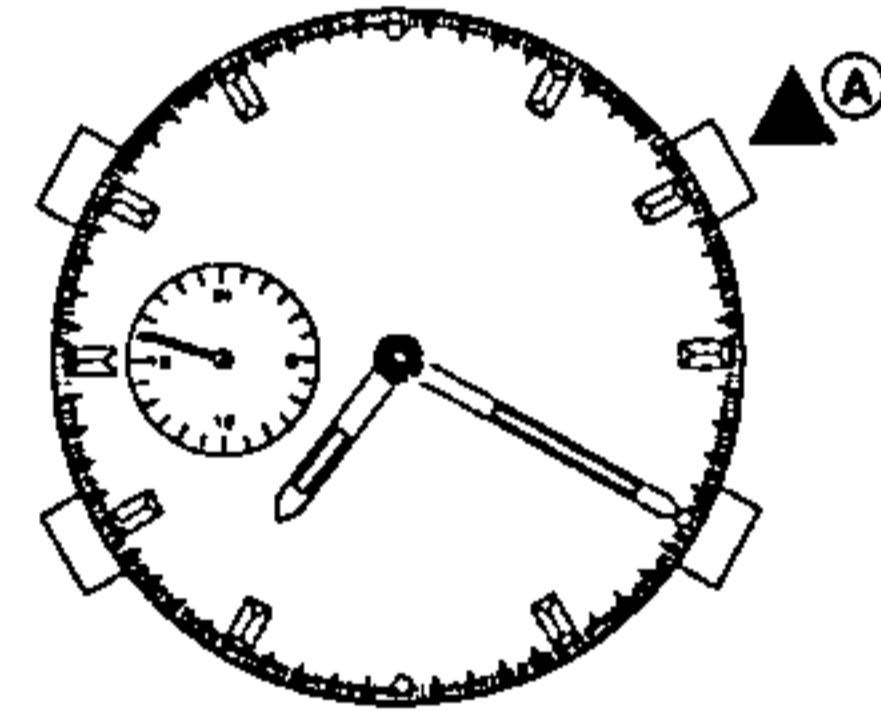

- Press the (A) button after setting the quick-set alarm and the hour/minute/second/24-hour hands will display the current time. **The quick-set alarm will be turned OFF.**

## 5. SETTING THE DAILY ALARM (AL-2)

Setting the alarm to ring everyday at 15:00.

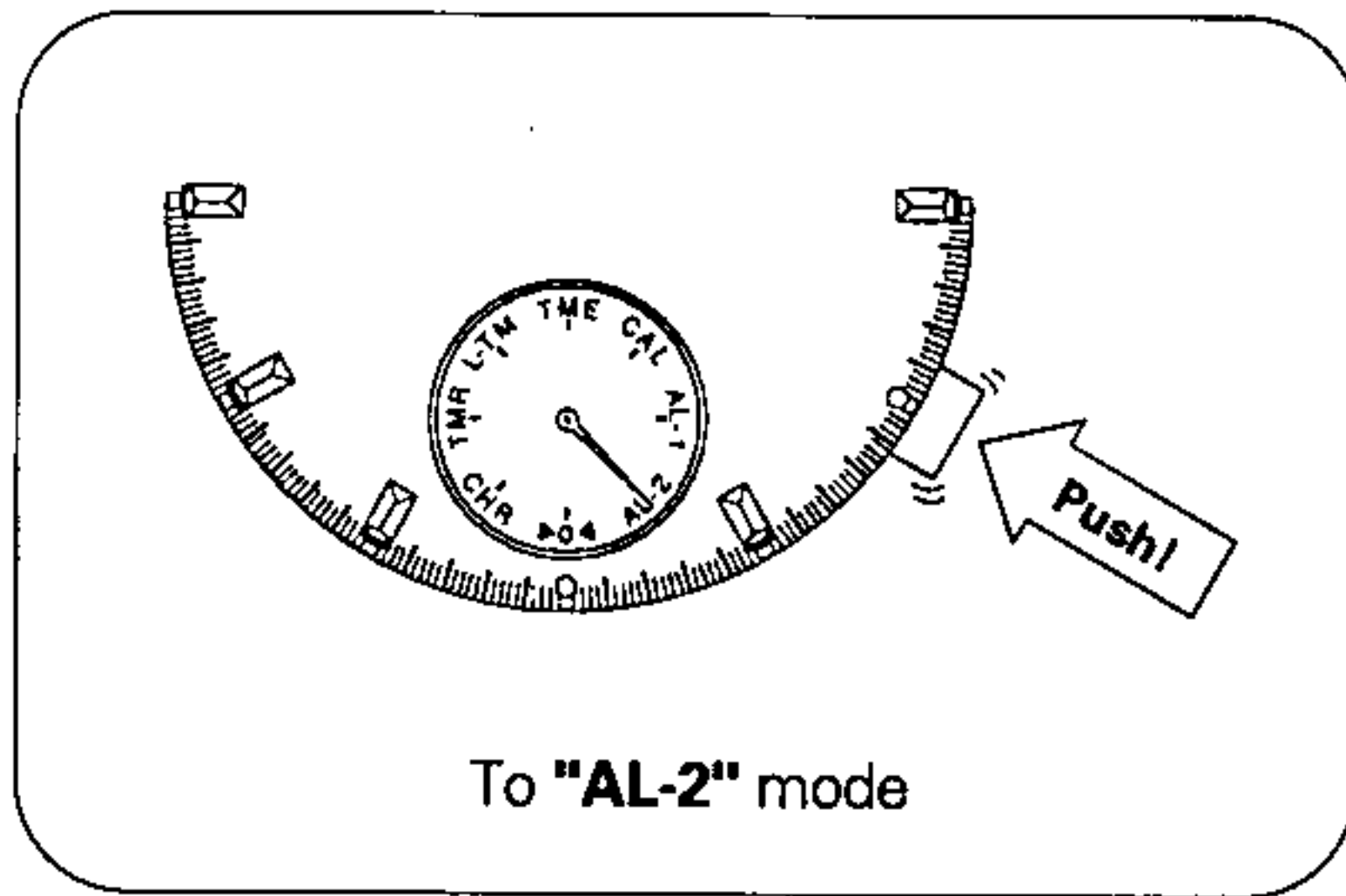

- **Daily Alarm function**

After the alarm time has been set once, the alarm will sound everyday at the same time for 15 seconds.

- **Alarm sound switch**

This switch lets you choose between 2 levels of sounds (loud or soft) for the alarm.

<M button normal position>

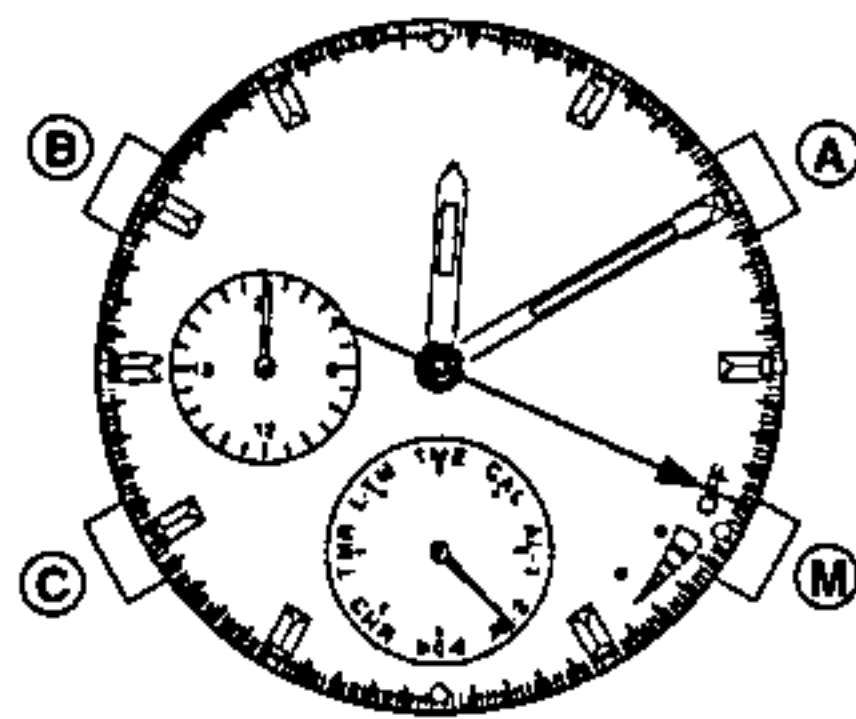

<Sound monitor>

(8 seconds)

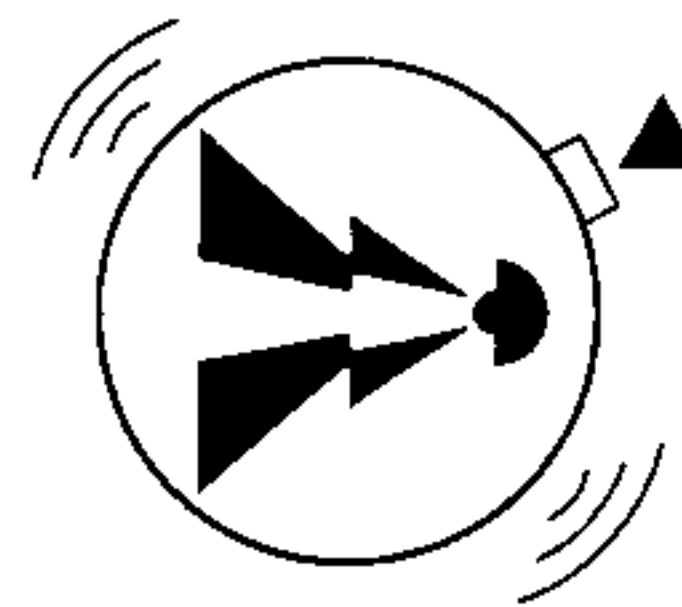

- Sound can be monitored by pressing the A button when the daily alarm is ON or OFF.

Setting procedures

<M button: 1st step position>

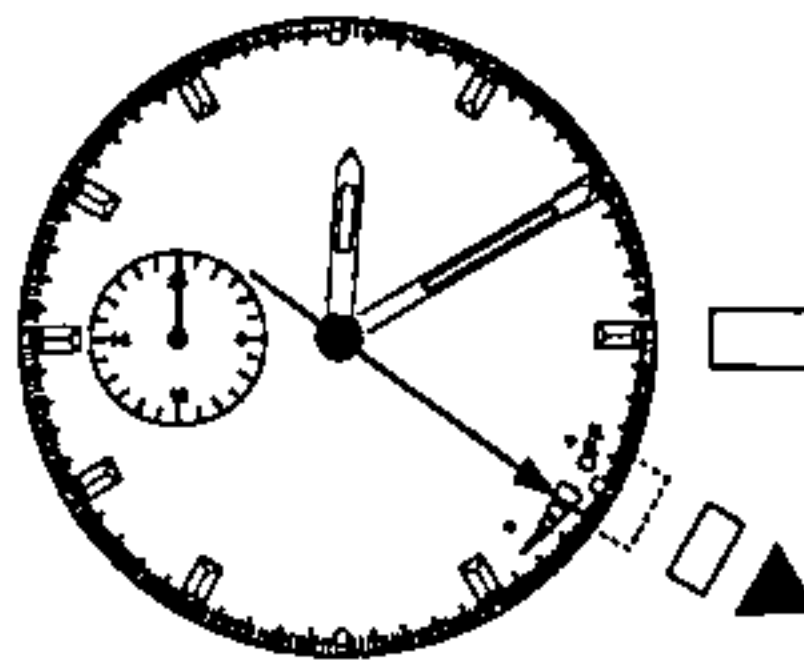

<Hour/minute setting>

clockwise

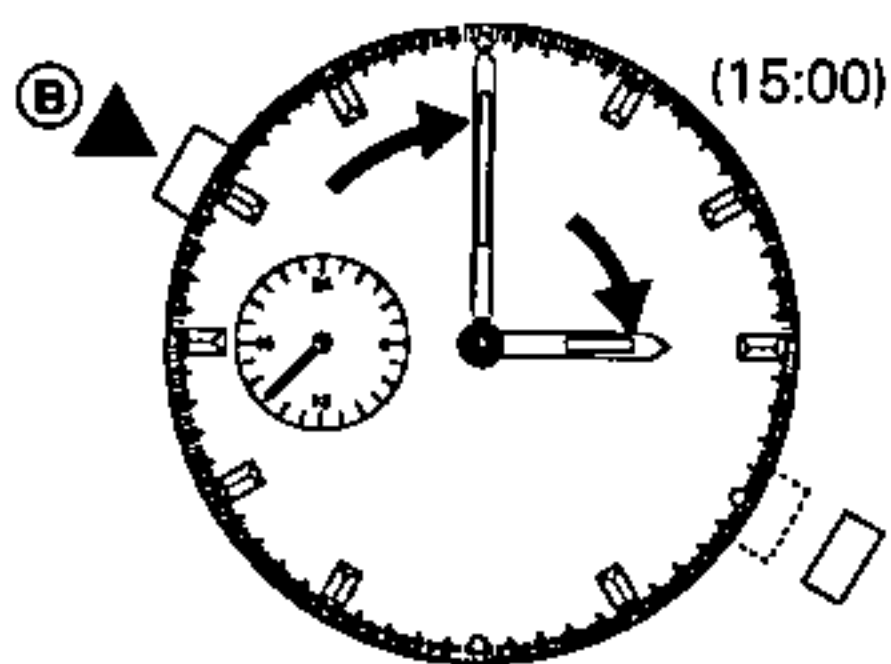

- ☆ Press and hold down either the B or C button to use the quick-advance feature.
- ☆ Quick advance function: Hour and minute hand movement is about twice as fast after the first revolution (clockwise movement only).
- ☆ Use the 24-hour system to ensure morning and afternoon times are set correctly.

<Hour/minute setting>

counterclockwise

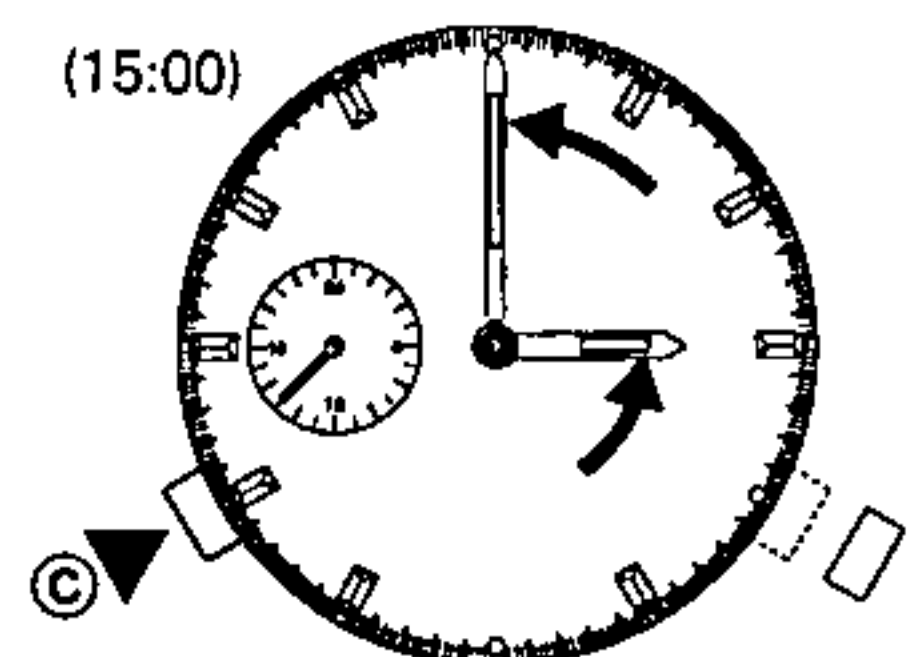

- ☆ The hour/minute/24-hour hands are synchronized.

**Daily alarm auto ON**  
**Daily alarm sound selector**

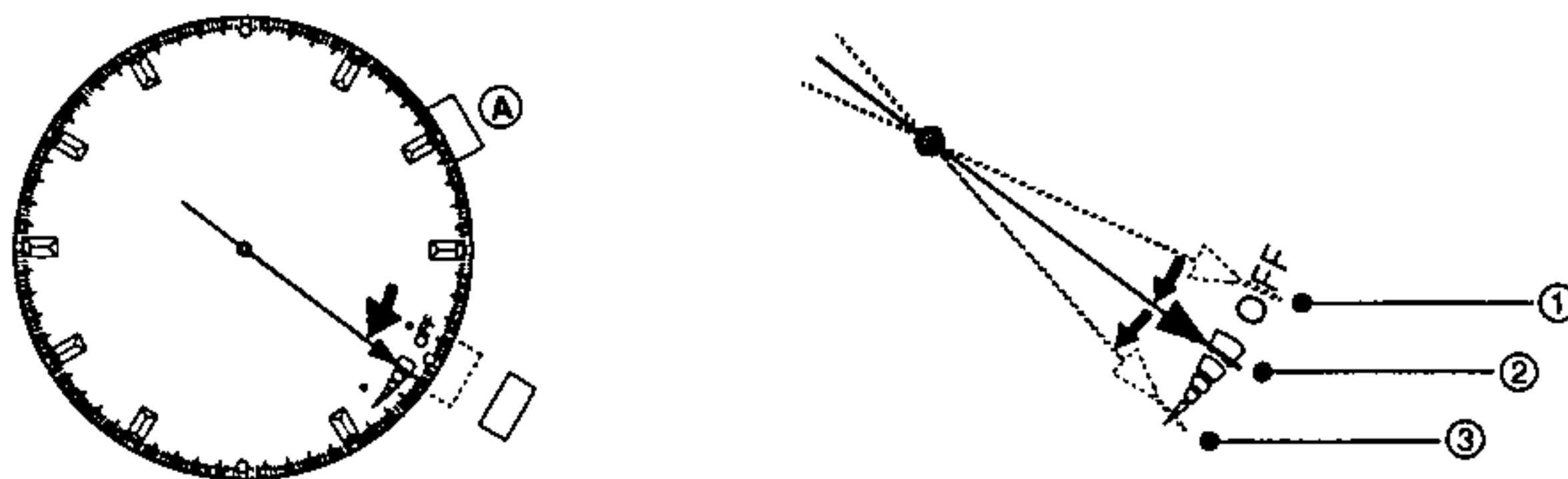

- Pull the (M) button out to the first step position. The second hand moves to position ② and the alarm is turned ON.
- Press the (A) button to switch between a softer or louder sound level, (The level of the alarm sound in position ③ is softer than position ②.) or to switch alarm OFF (Position ①).

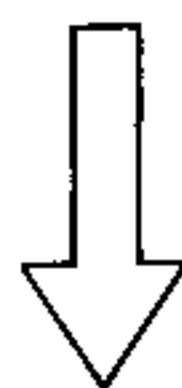

**<Push the (M) button in to the normal position>**  
**Alarm setting is complete**

(15:00)

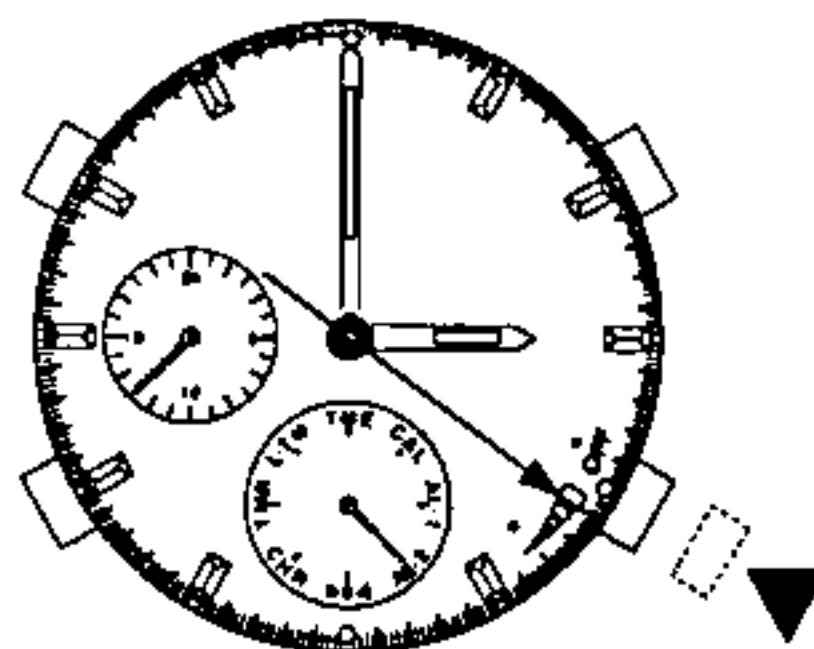

## 6. STOPWATCH OPERATION (CHR)

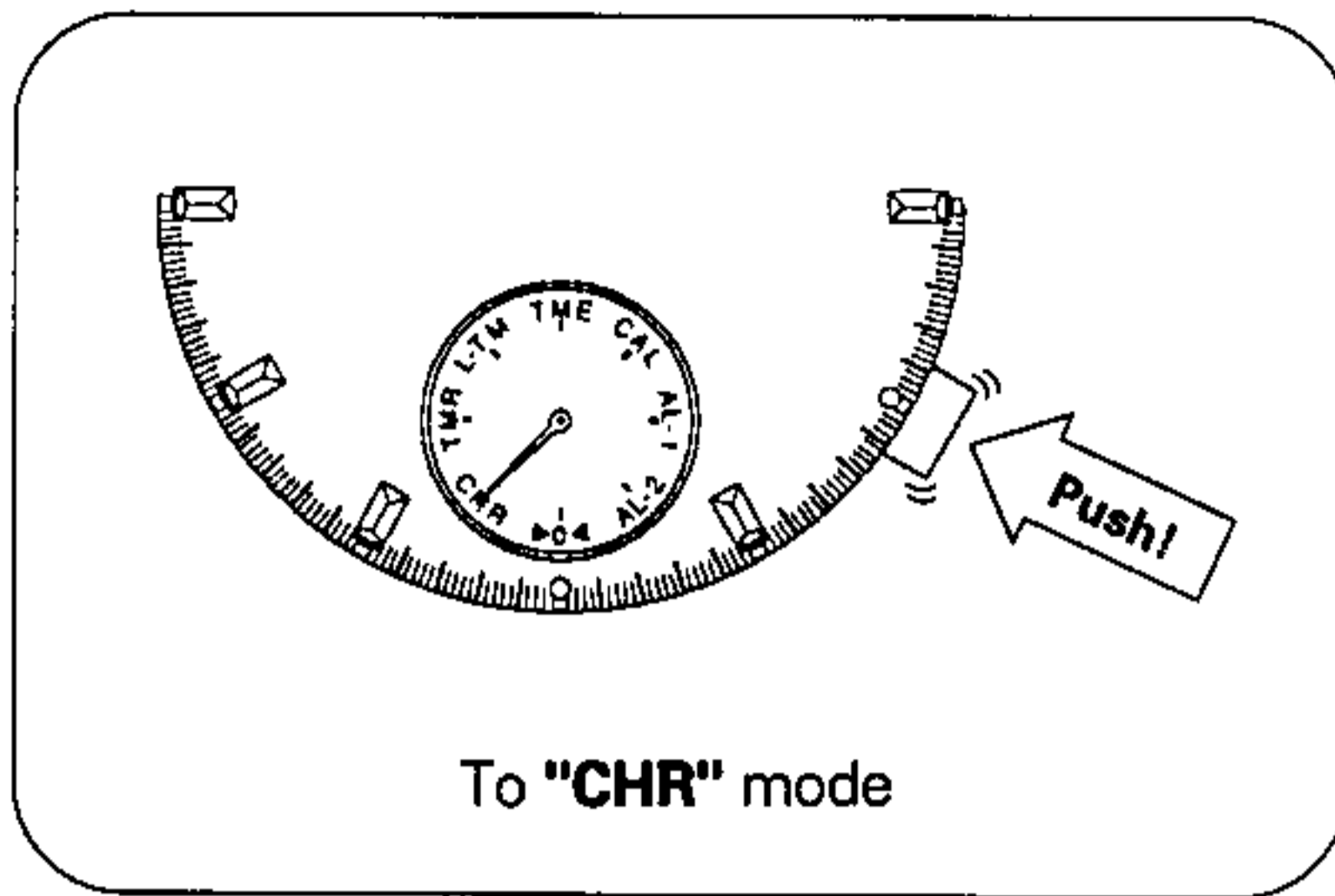

- **Max. stopwatch range:** 60 minutes in 1/20 sec. intervals.  
The auxiliary hand displays in 1/20 sec. increments.
- Starting from the stopwatch reset state, the auxiliary hand advances for 1 minute. The number of elapsed minutes exceeding one minute are displayed.
- The hour/minute/24-hour hands display the current time in the stopwatch mode.

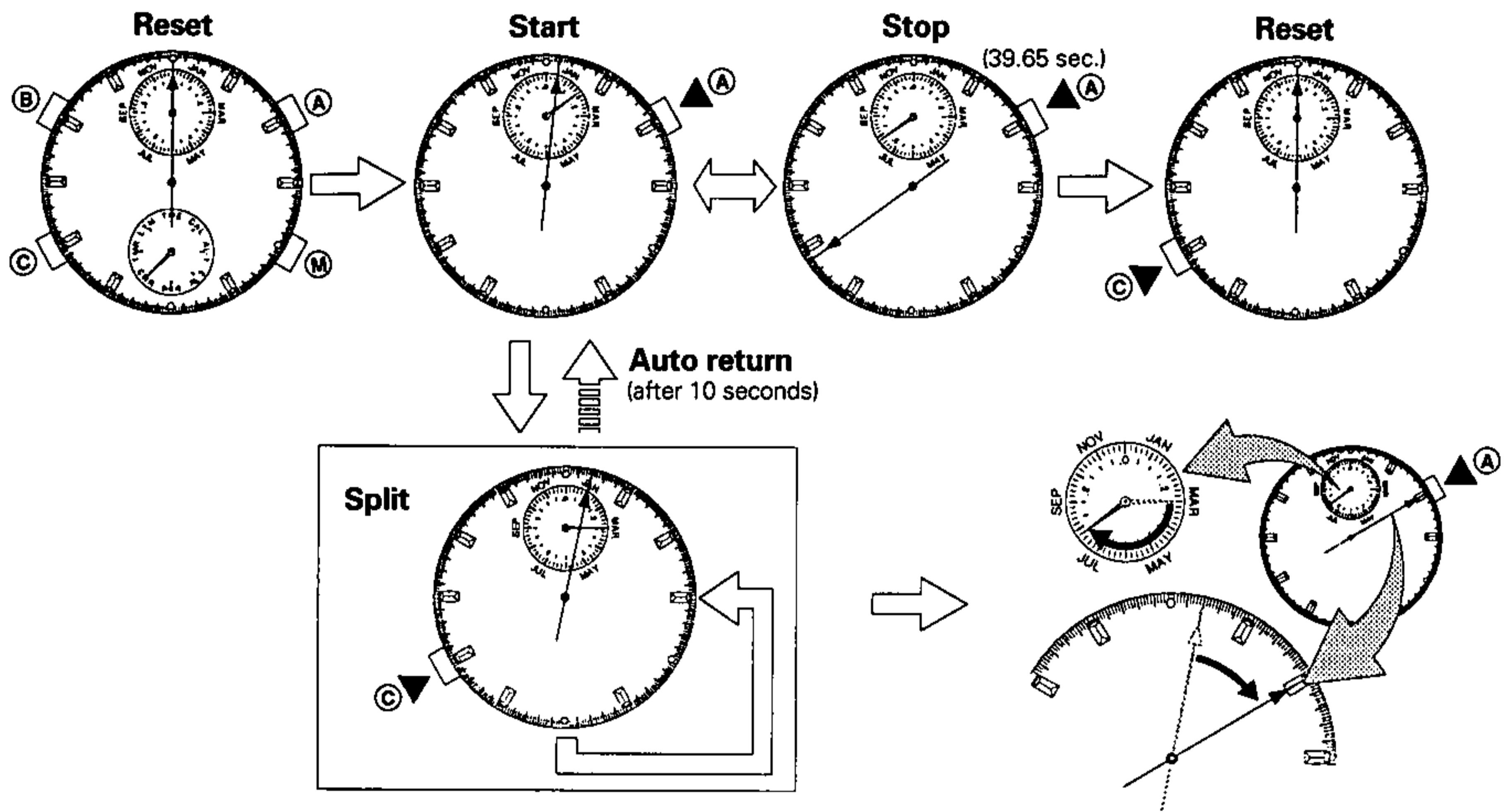

**1/20 sec. Display** (effective only timings exceeding 1 minute.)

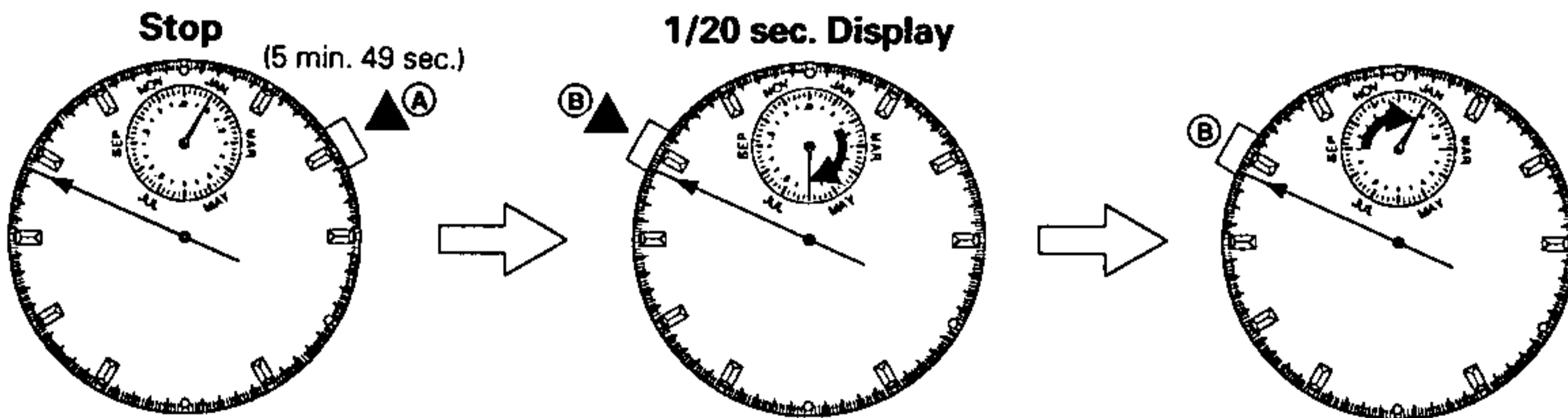

- 1/20 sec. displays only while the (B) button is held down.
- Release the (B) button to display the number of elapsed minutes with the auxiliary hand.



## 7. SETTING THE TIME (TMR)

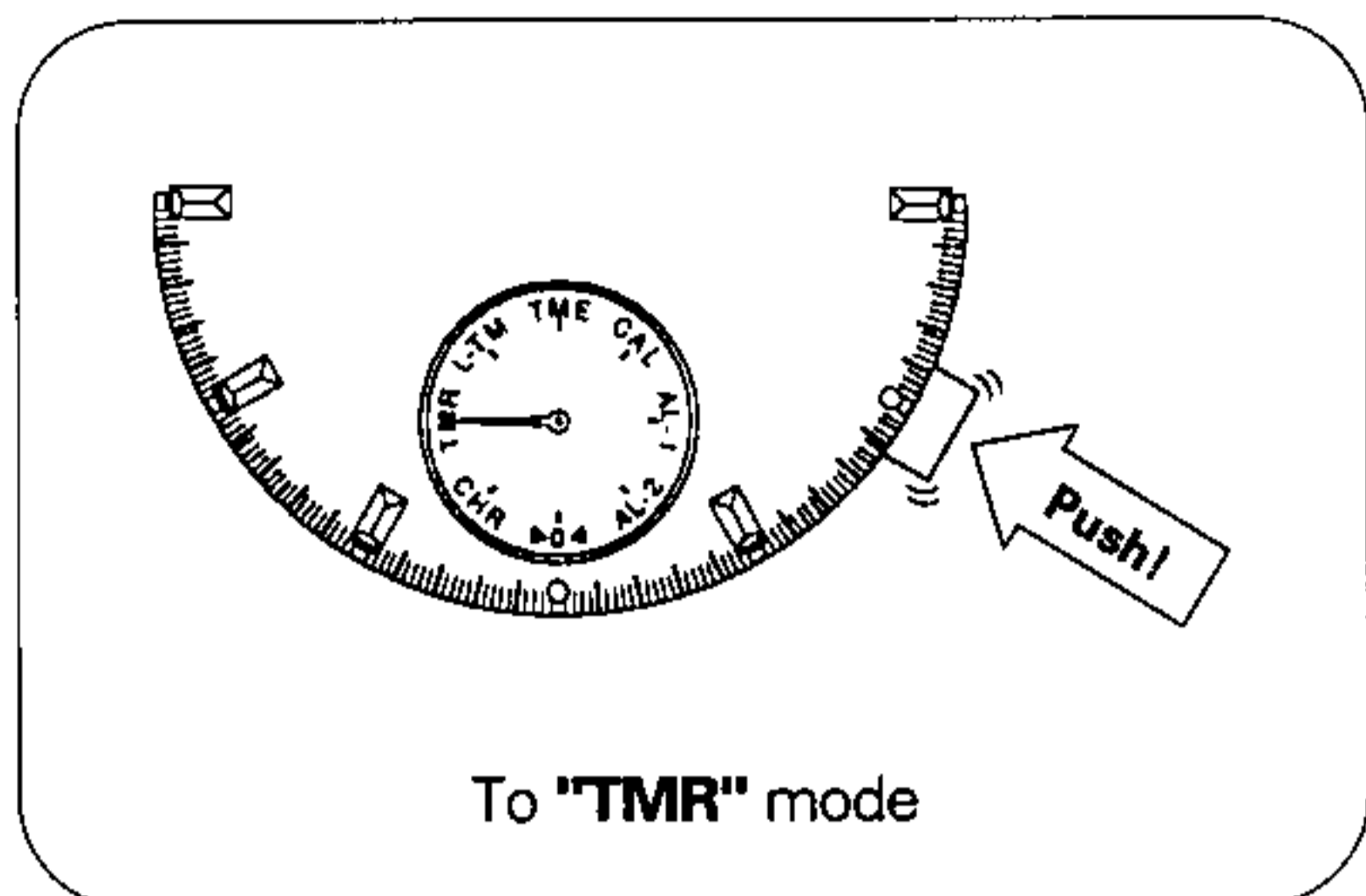

- Max. timer range: 60 minutes in 1-minute intervals.
- Flyback function: This feature allows you to press the © button after the timer countdown has started to return to the beginning of the timer setting and automatically start the countdown over again.
- The hour/minute/24-hour hands display the current time in the timer mode.

### Setting the timer to 10 minutes <Timer setting procedures>

Ⓜ button normal position

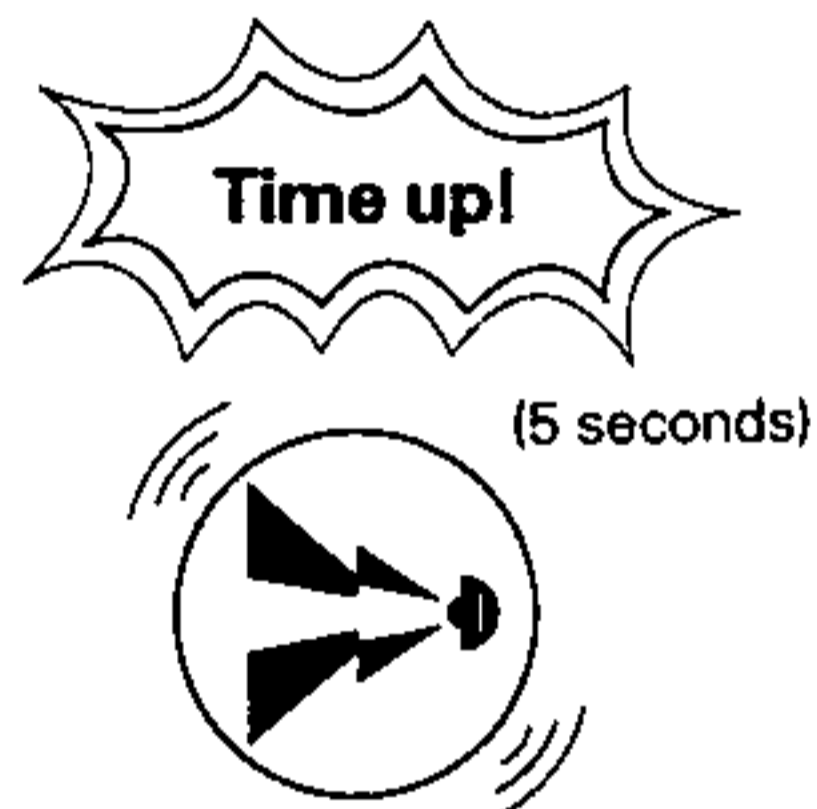
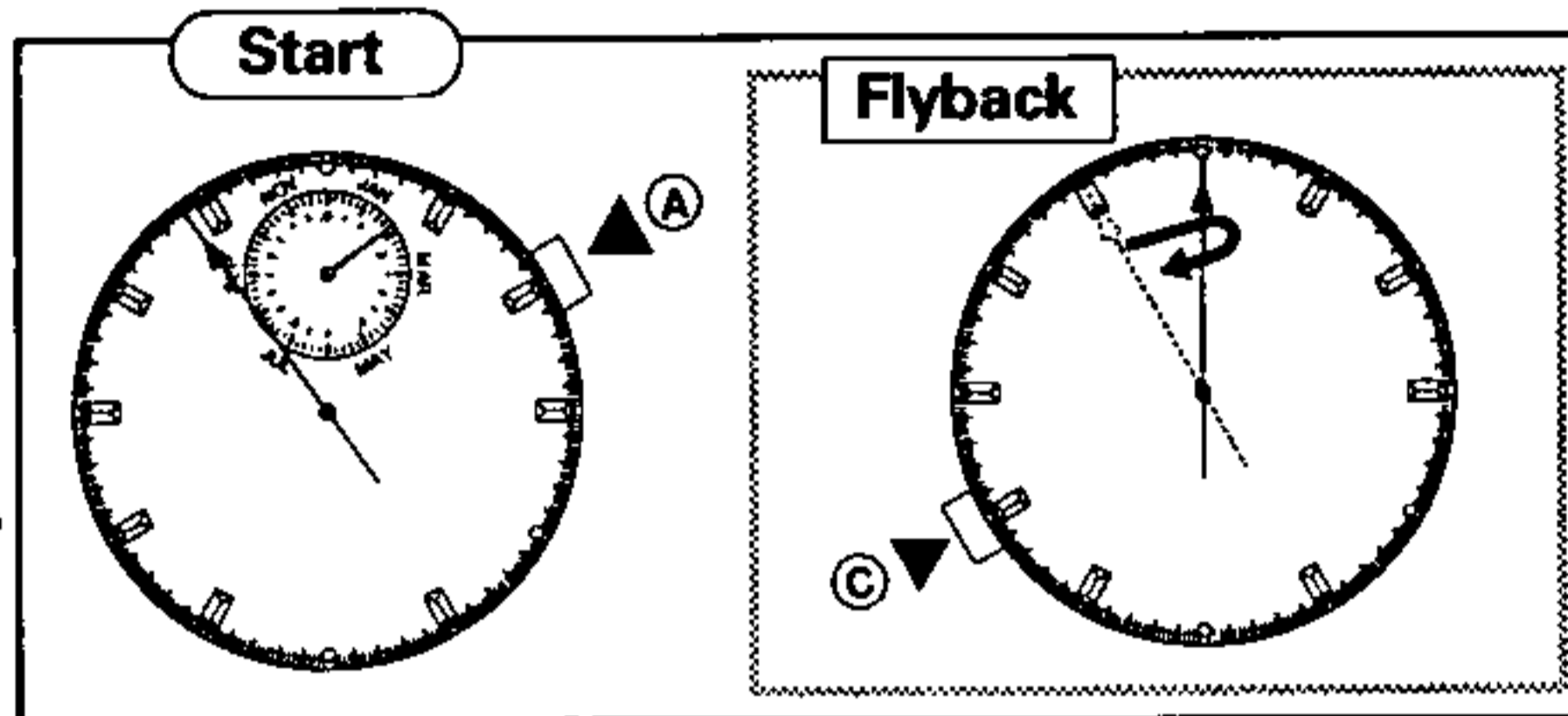
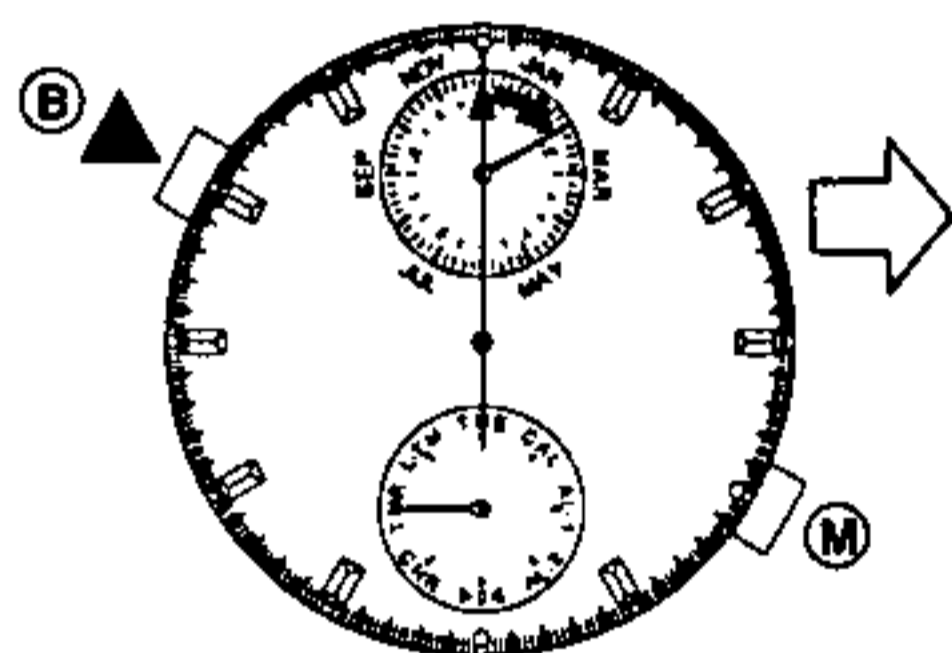

### Timer settings are made with the auxiliary hand

- Auxiliary hand (timer minutes)
  - Second hand (timer seconds)
- Countdown proceeds at same time

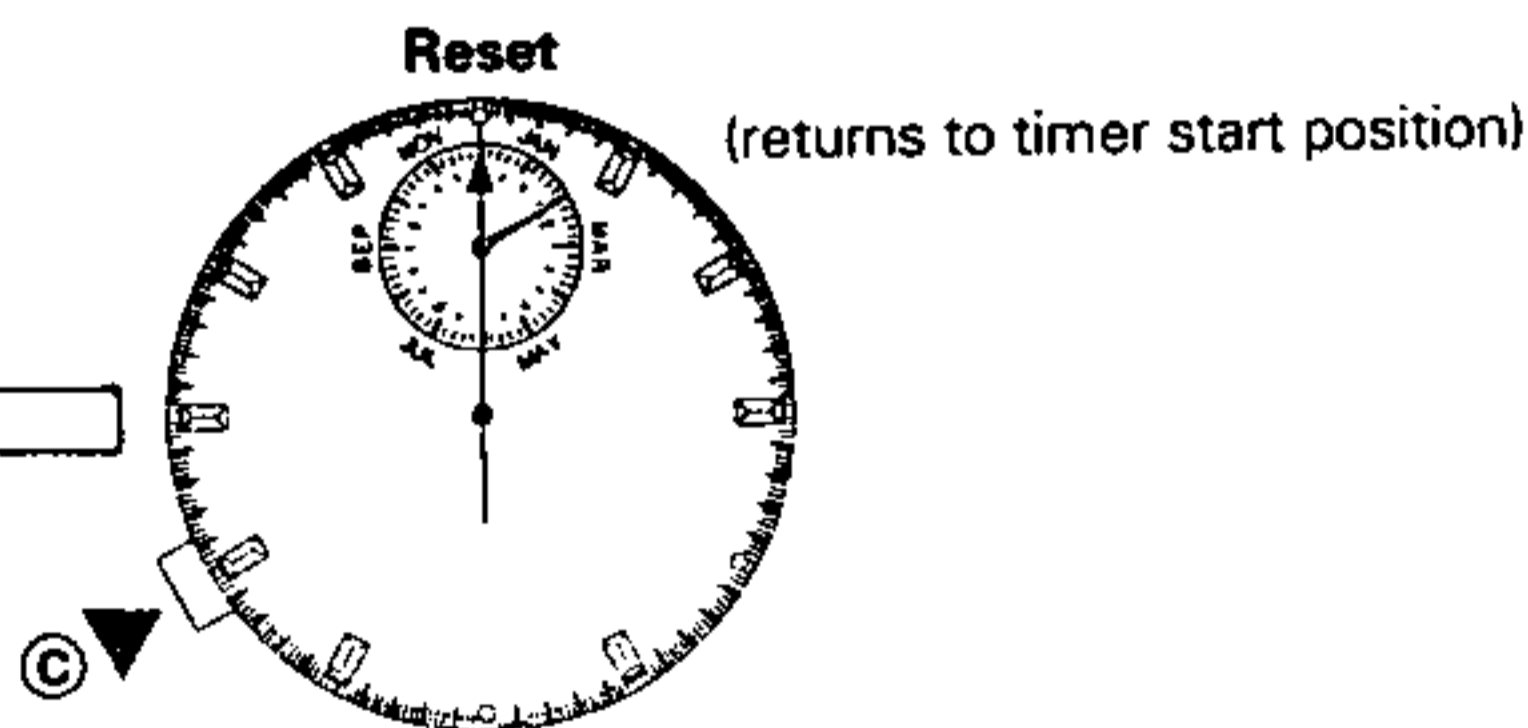
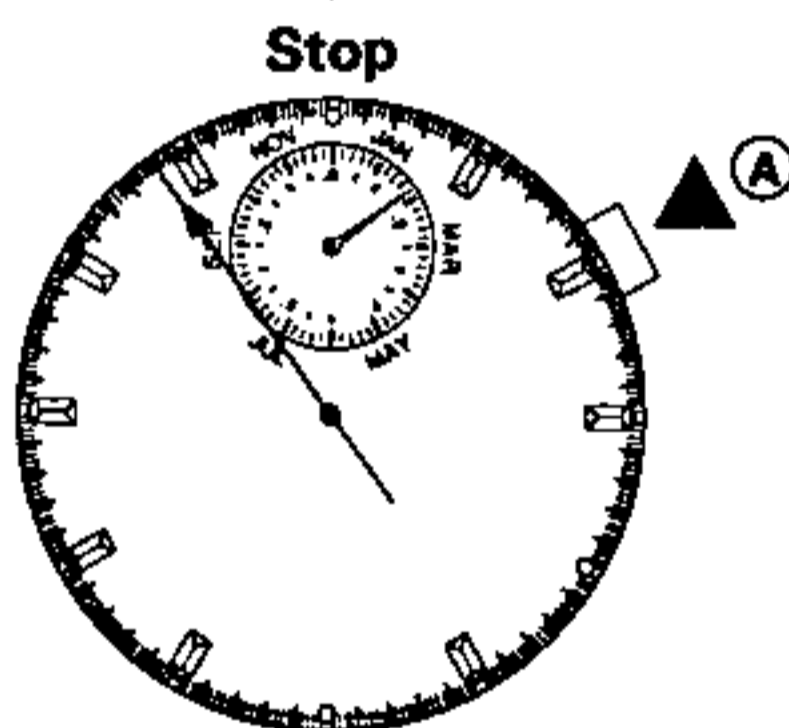

- ☆ A confirmation beep sounds with each start, stop, reset and flyback operation.
- ☆ Press and hold down the Ⓟ button to use the quick-advance feature while setting the timer.

## 8. SETTING THE LOCAL TIME (L-TM)

Changing the local time from 10:20 to 15:20.

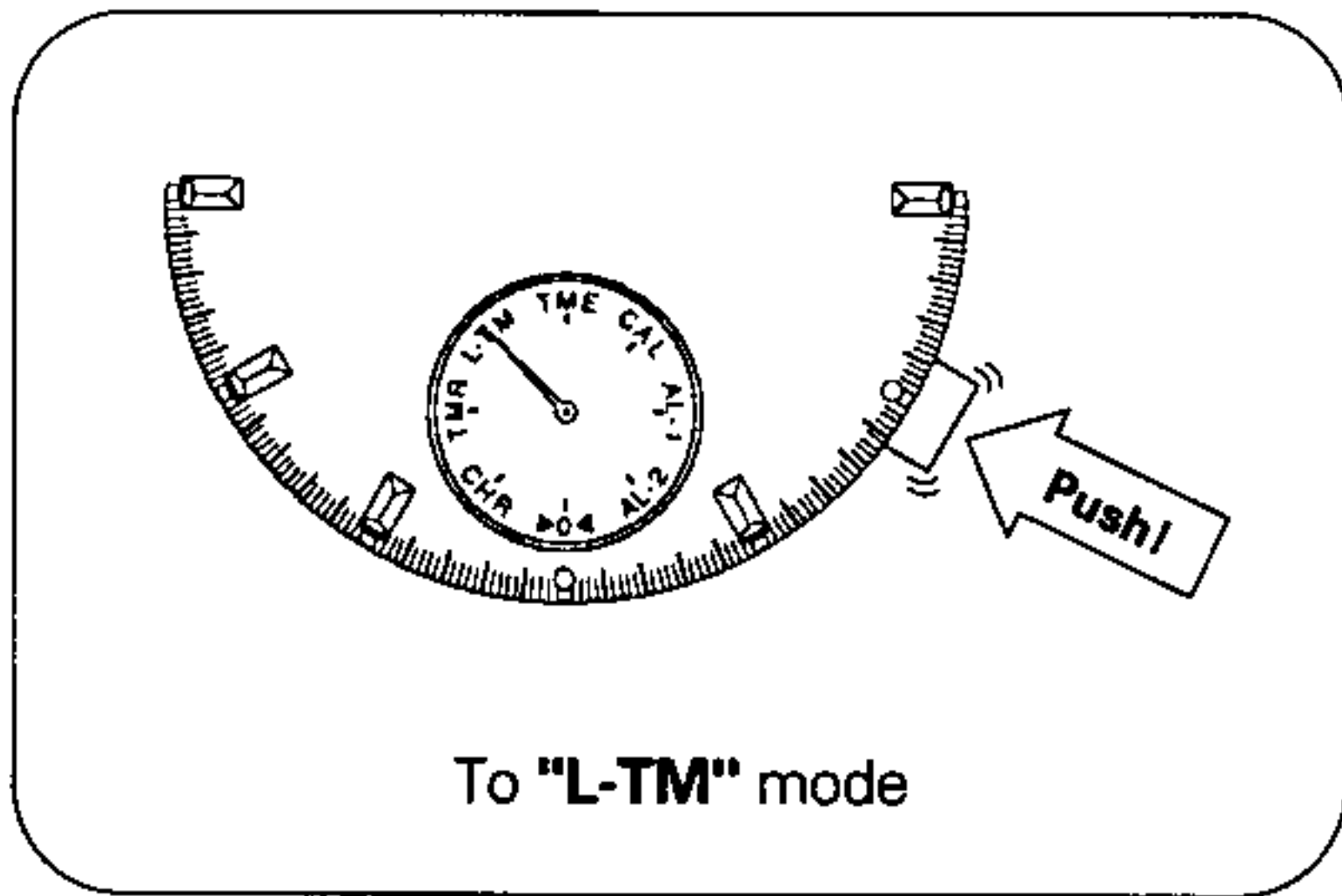

- Local time is the time in the current location. On business trips and the like, the dual time feature can be used by setting the watch to the local time.

### Setting procedures

<M button normal position>

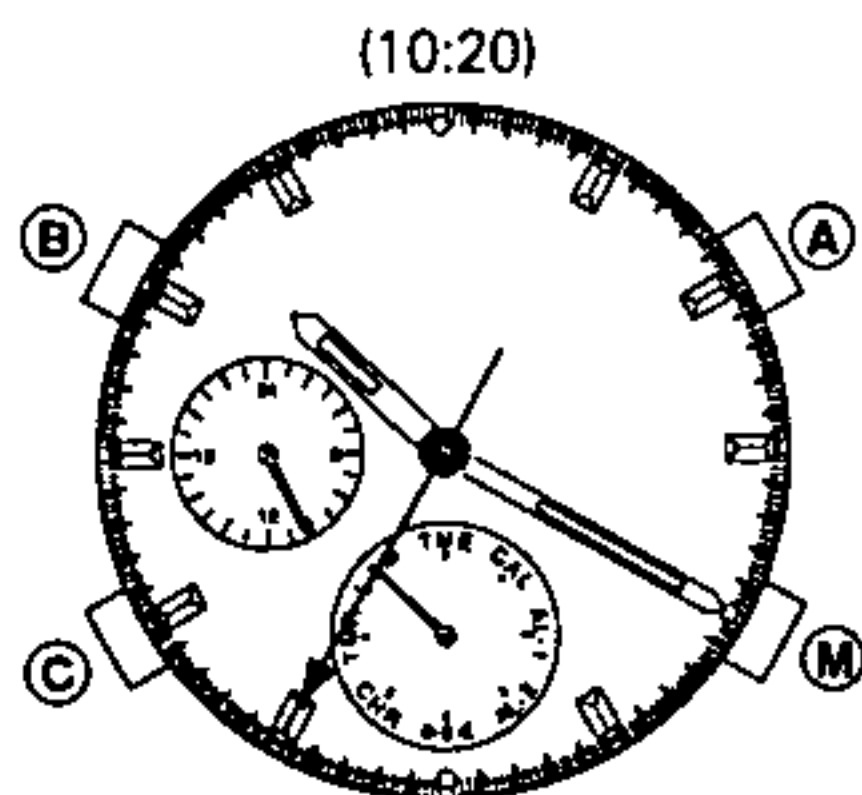

<M button: 1st step position>

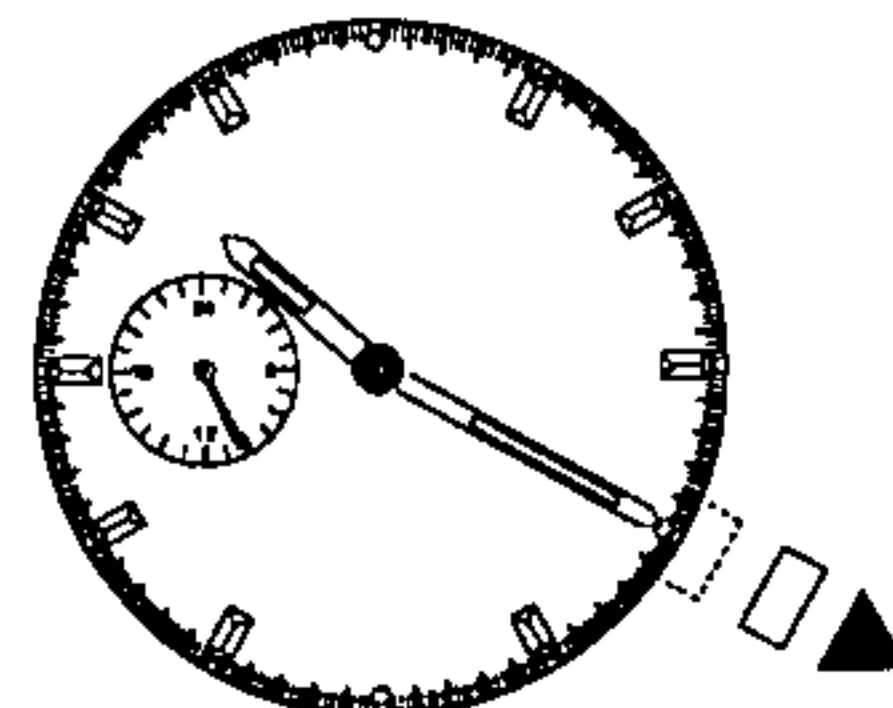

<Hour/minute setting>

clockwise

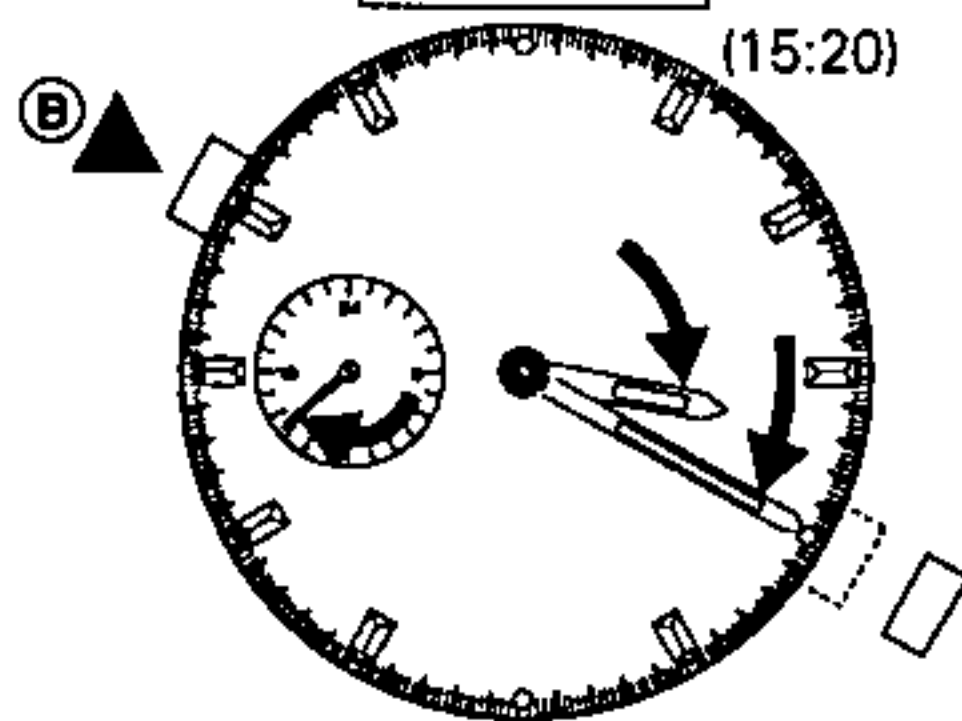

<Hour/minute setting>

counterclockwise

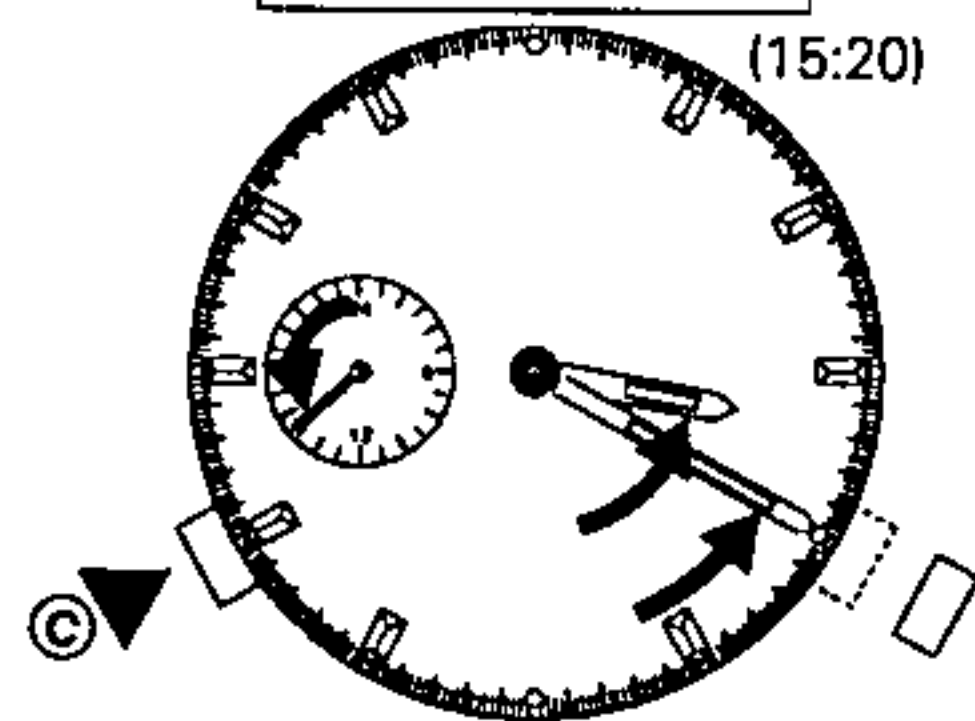

- Press and hold down either the (B) or (C) button to use the quick-advance feature.
- Hour/minute/24-hour hands are synchronized.
- Minute hand is adjustable in 30-minute increments only. Second hand is not adjustable.

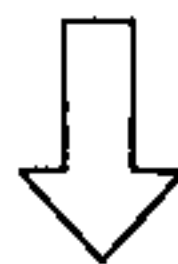

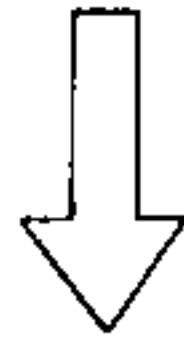

<Push the (M) button in to the normal position>  
Local time setting is complete at 15:20

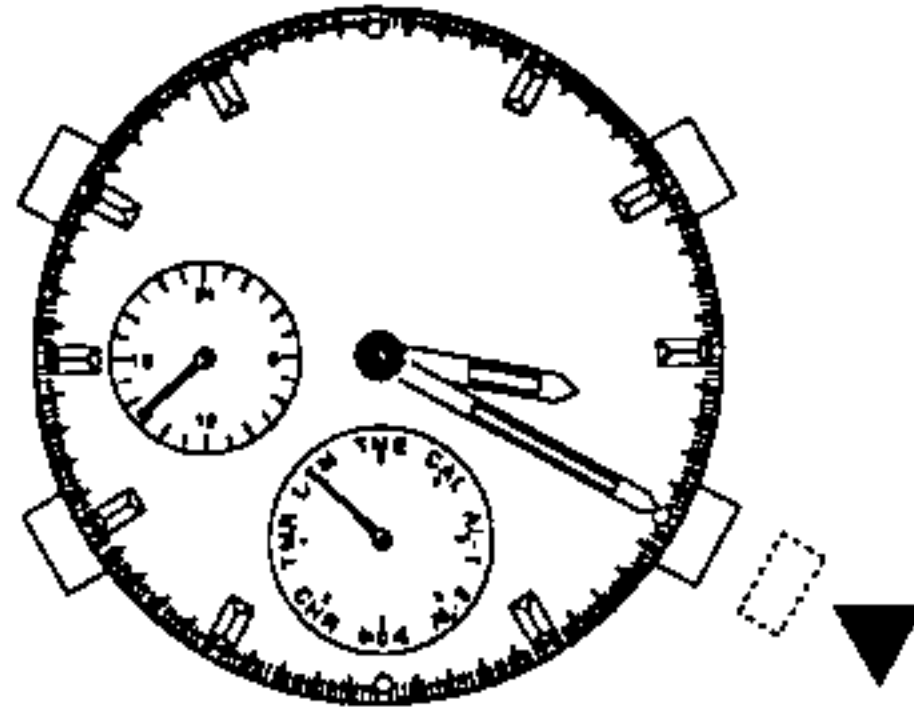

## 9. MONITORING IN THE NORMAL TIME MODE

### a. Calendar Monitor

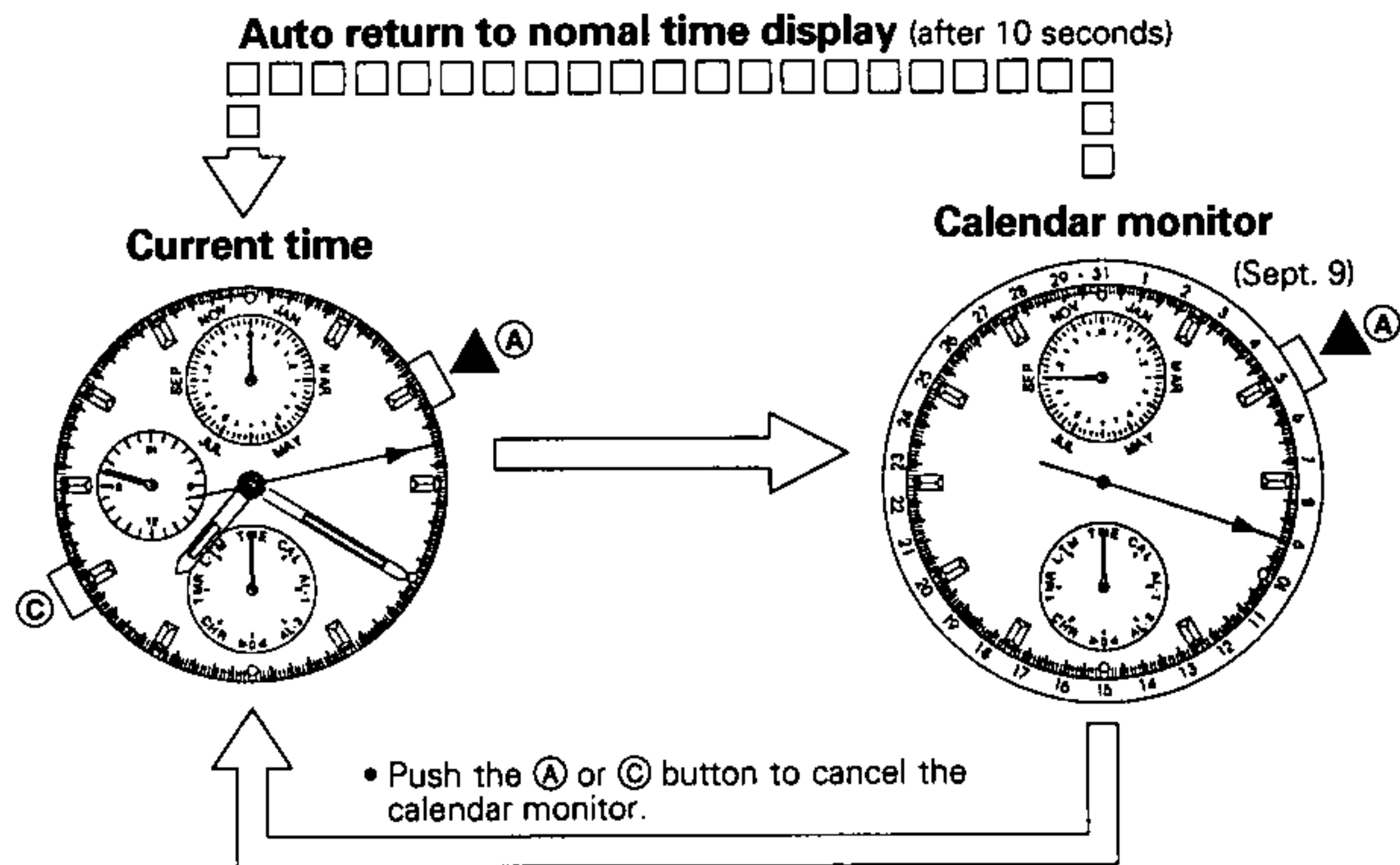

### b. Daily alarm (AL-2) Set Monitor

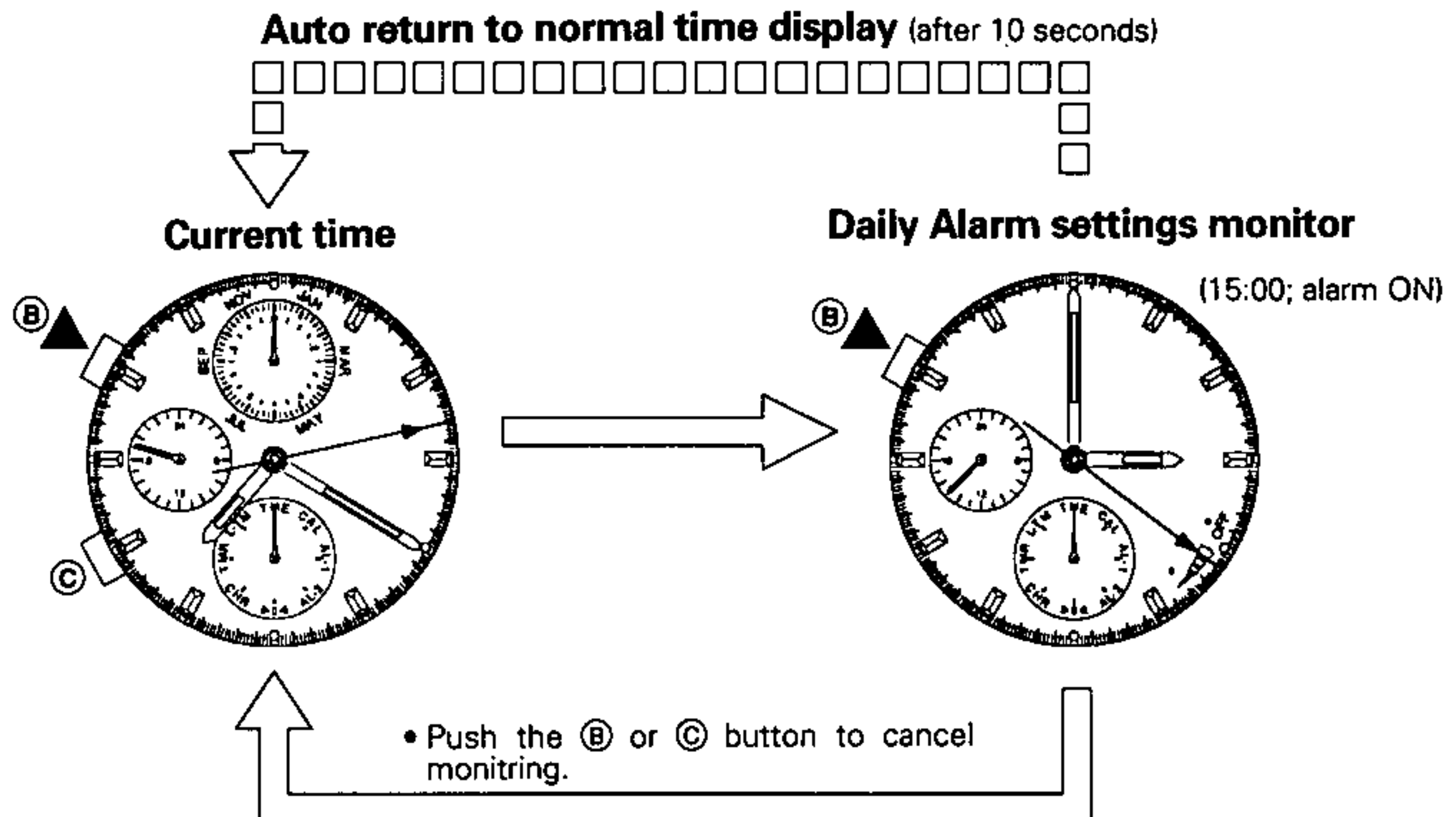

- ☆ Press the (B) button while monitoring the calendar to monitor the alarm (AL-2) settings.
- ☆ Press the (A) button while monitoring the daily alarm (AL-2) settings to monitor the calendar settings.
- ☆ Both of the above monitor modes automatically return to the current time after 10 seconds. (**auto return**)

## 10. ALL RESET FUNCTION

The all reset function is used following battery replacement or abnormal watch movement

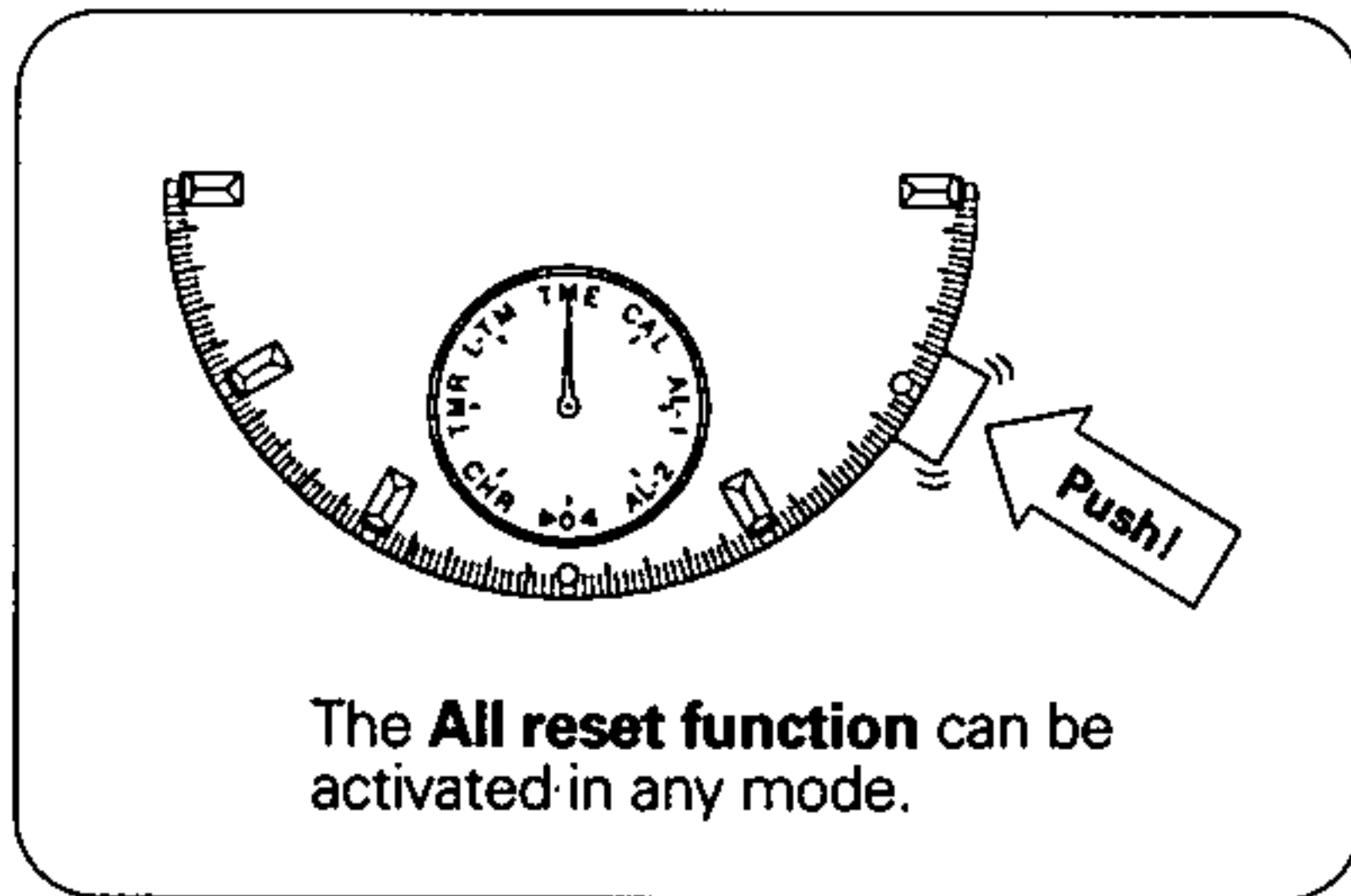

### All reset procedure

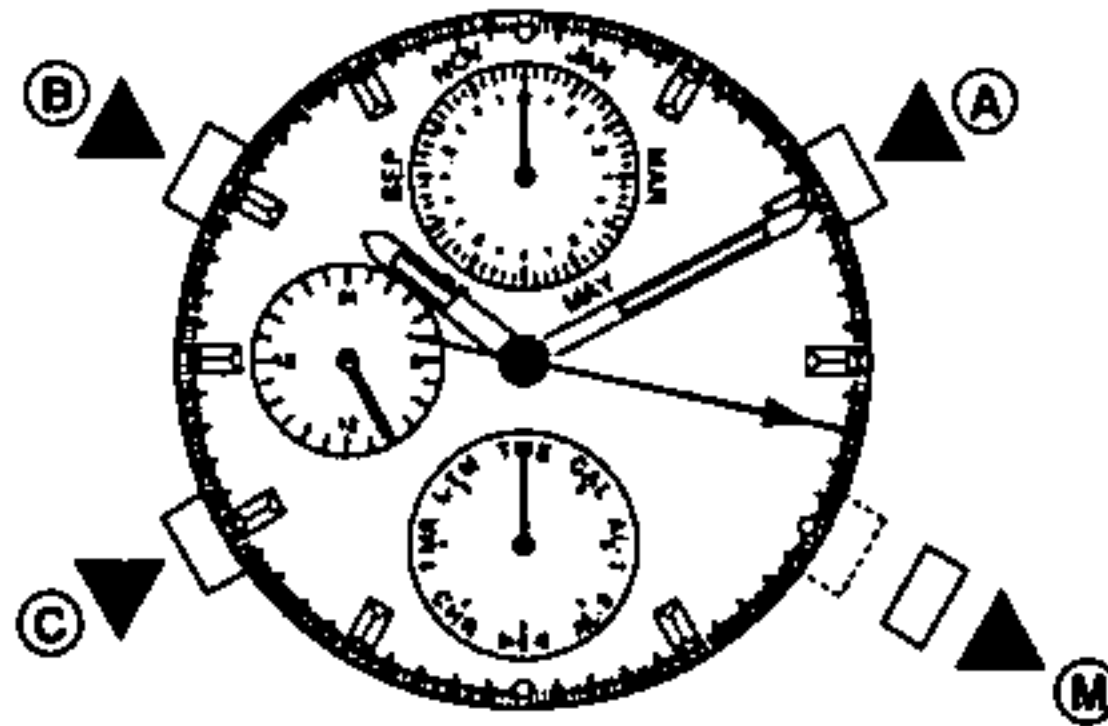

1. Pull the (M) button out to the first step position.
2. Push and hold down the (A), (B), (C) buttons simultaneously for more than 2 seconds.
3. Release all three buttons and a confirmation beep will sound and the minute, second, auxiliary hands will move slightly. Push (M) button in to the normal position after completing the above procedures and **set all hands (except mode hand) to 0.** (See **BEFORE USE: "Zero position setting"**, and then set the time.)

## 11. CALCULATOR OPERATION

The following points should be considered when using the calculator function.

- Use the calculator as a standard measurement device.
- The calculator's scale cannot be used for unit measurement.

### Calculator

#### 1) Elapsed-time calculations

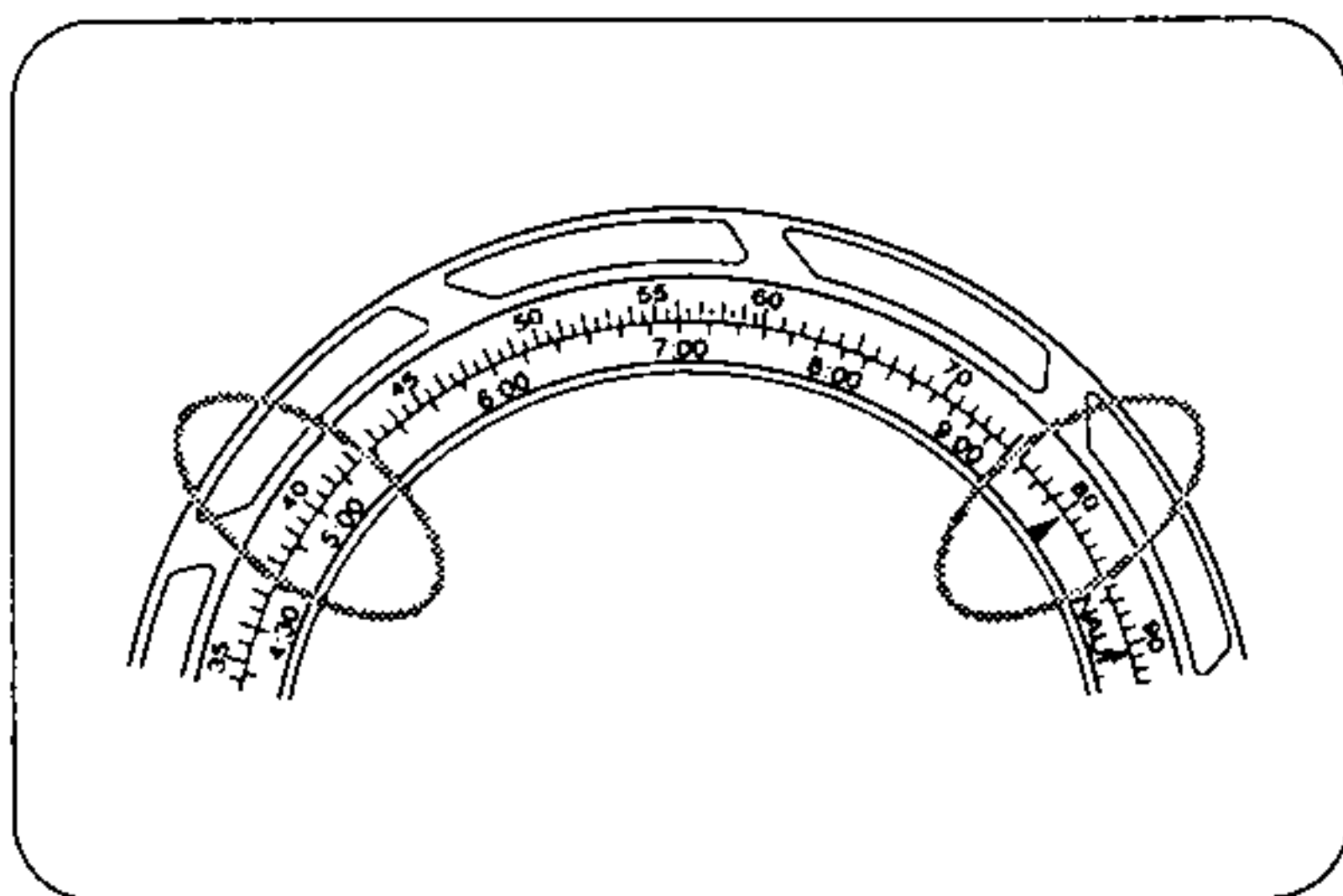

**Example:** How long will it take a car traveling 80kph to go 400 kilometers?

**Calculation:** Align 80 on the outer scale with the Speed Index (▲) mark on the inner scale. The position on the outer scale at 40 will now be lined up with 5:00 (5 hours) on the inner scale.

#### 2) Speed calculations

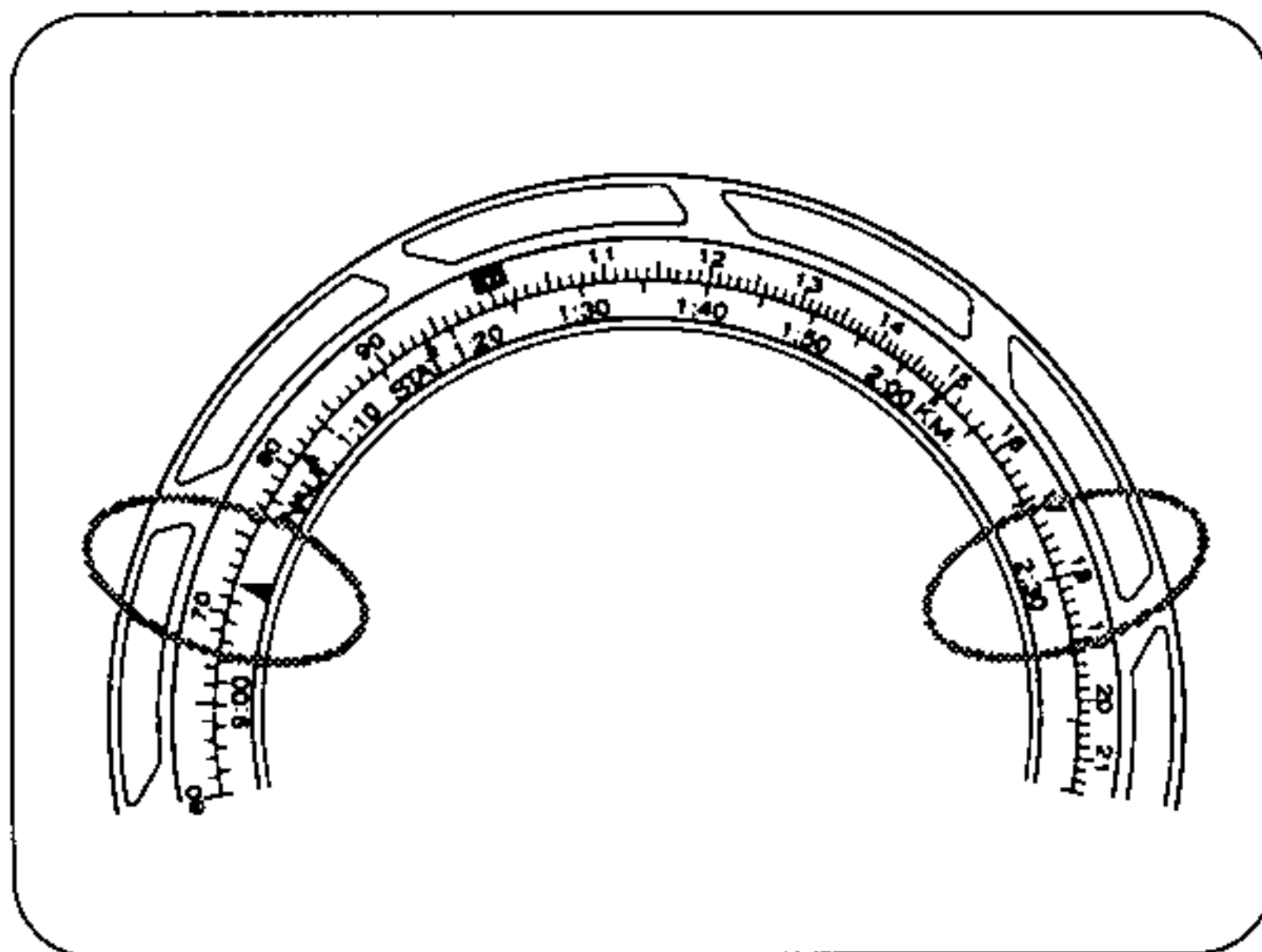

**Example:** If a car goes 180km in 2 hours 30 minutes, how fast was the car traveling?

**Calculation:** Align 18 on the outer scale with 2:30 on the inner scale. The Speed Index (▲) mark on the inner scale will line up with 72 (km).

#### 3) Distance calculations

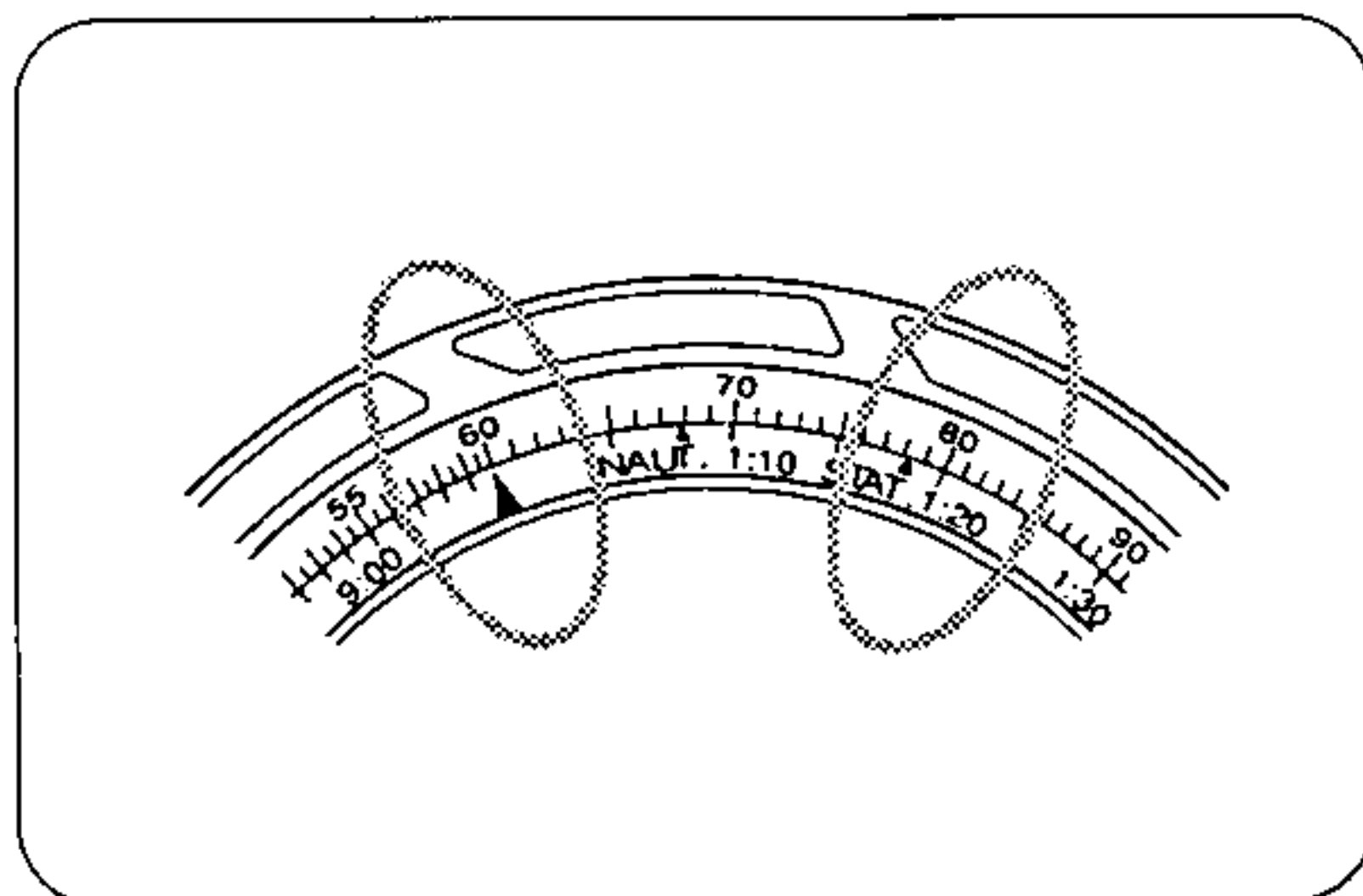

**Example:** How far will a car go if it travels at 60kph for 1 hour 20 minutes?

**Calculation:** Align 60 on the outer scale with the Speed Index (▲) mark on the inner scale. The position on the inner scale at 1:20 will now be lined up with 80 (km) on the outer scale.



#### 4) Fuel consumption rate calculations

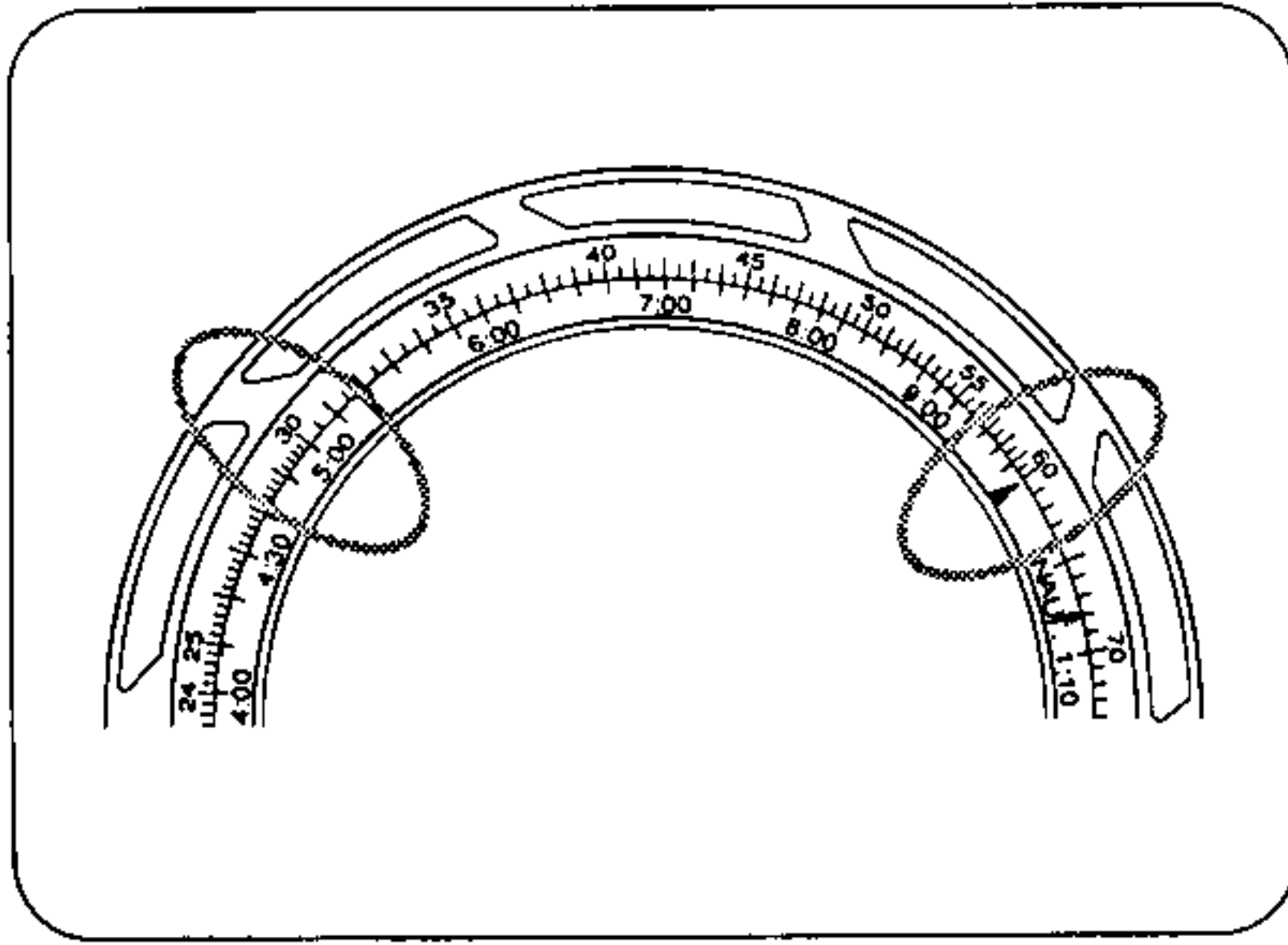

**Example:** If a car travels 5 hours and uses 30 liters of fuel, how many liters of fuel per hour does the car use?

**Calculation:** Align 30 on the outer scale with 5:00 on the inner scale. The Speed Index (▲) mark will now be lined up with 60 (6 liters/hr) on the outer scale.

#### 5) Total fuel consumption calculations

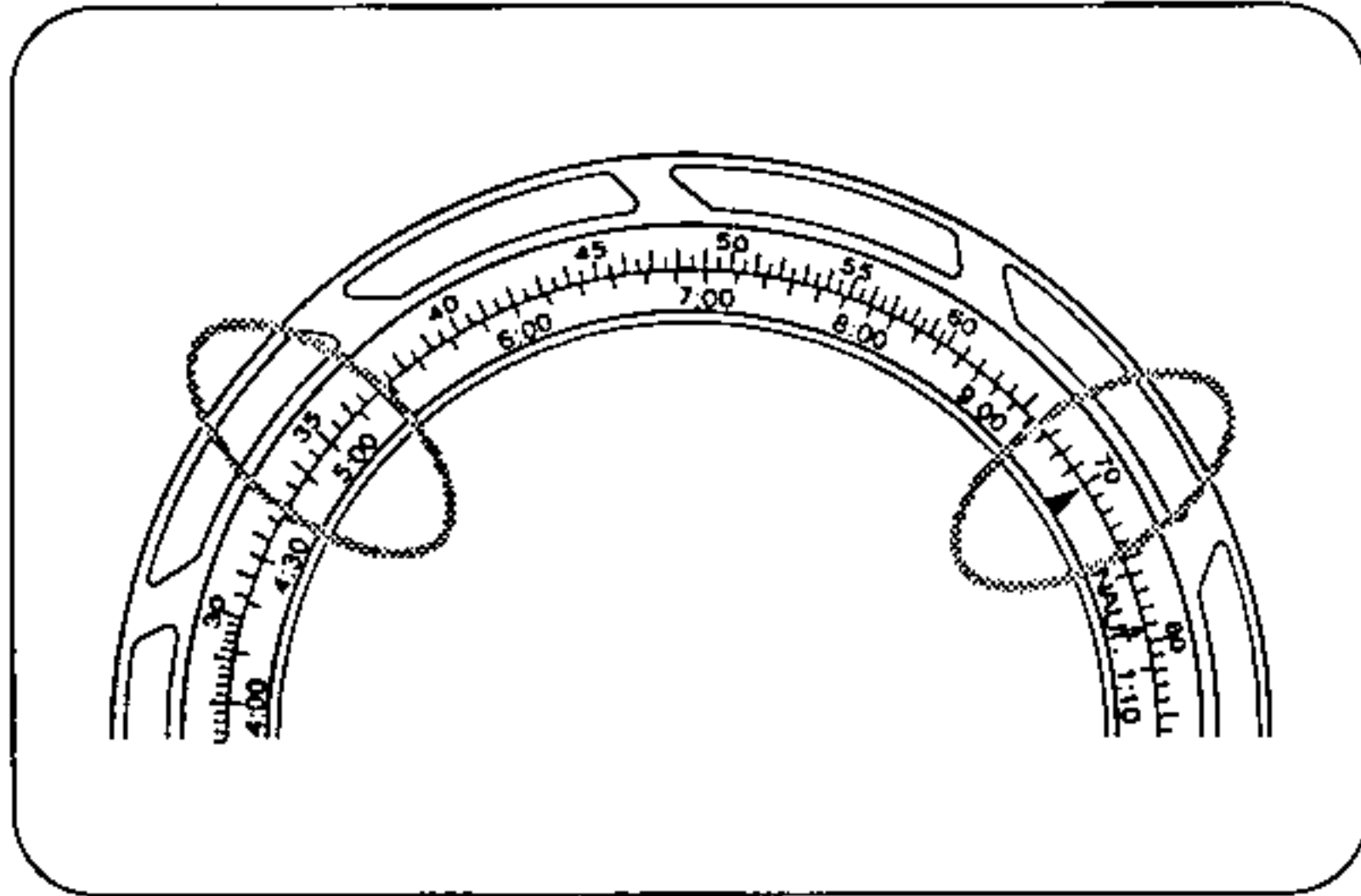

**Example:** How many liters of fuel does the car need to travel 5 hours if a car burns 7 liters per hour?

**Calculation:** Align 70 on the outer scale with the Speed Index (▲) mark on the inner scale. The position on the inner scale at 5:00 will now be lined up with 35 (liters) on the outer scale.

#### 6) Travel time calculations

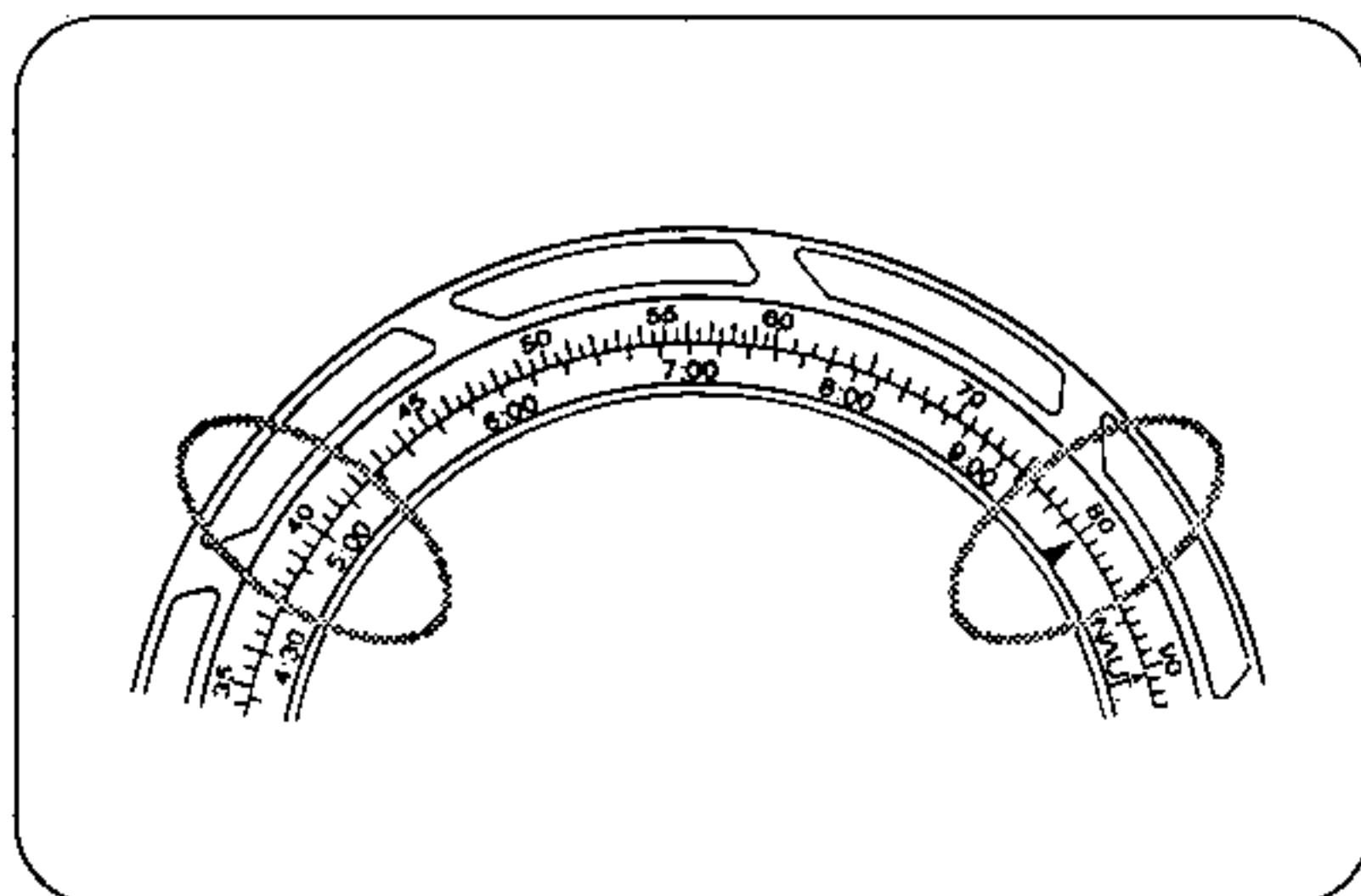

**Example:** If a car has 40 liters of fuel and burns it at a rate of 8 liters per hour, how many hours will the car be able to travel?

**Calculation:** Align 80 on the outer scale with the Speed Index (▲) mark on the inner scale. The position on the outer scale at 40 will now be lined up with 5:00 (5 hours) on the inner scale.

## 7) Conversion calculation

- Kilometer, mile and knot conversion calculations are possible.

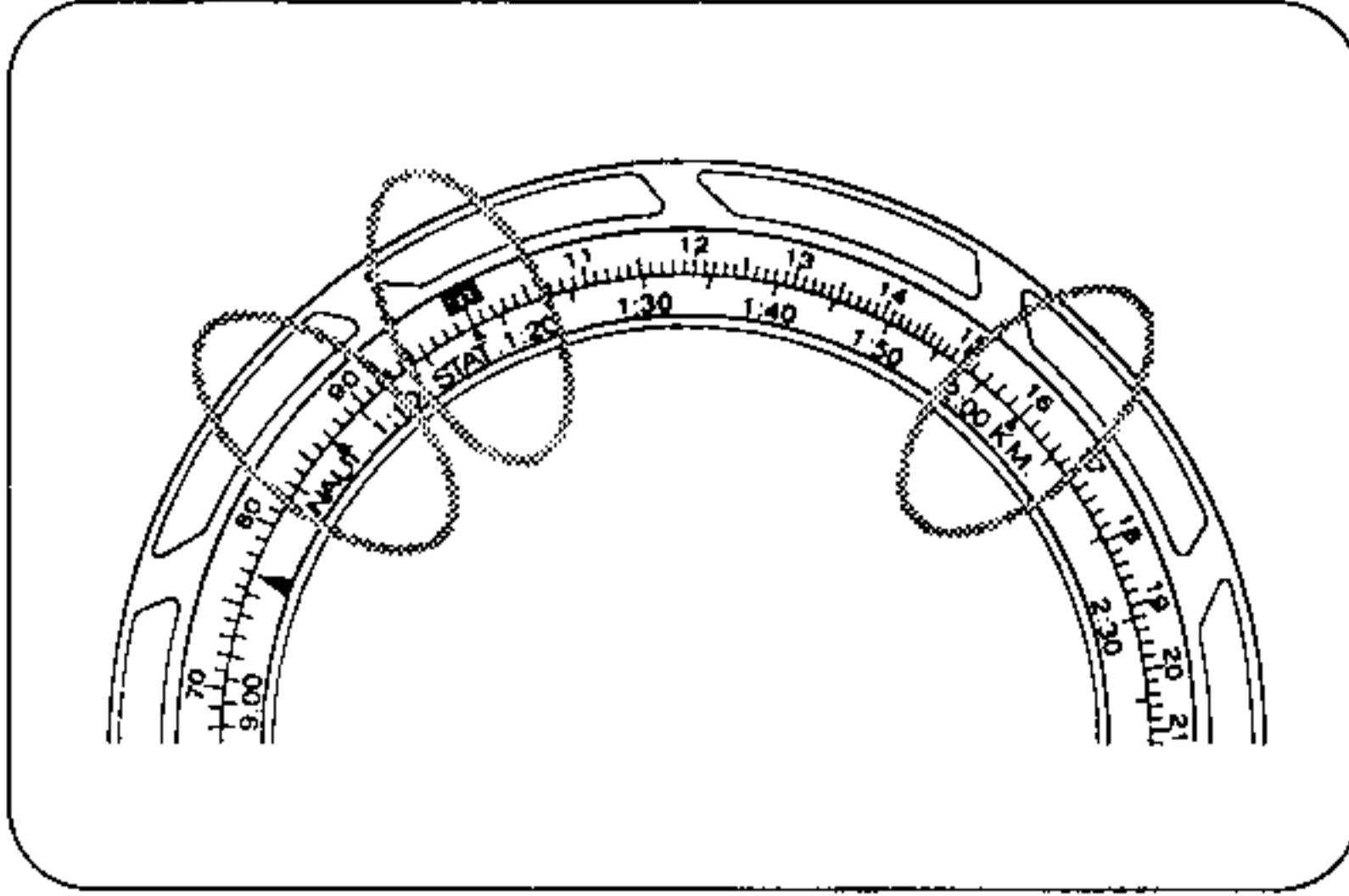

**Example:** One mile equals how many kilometers?

**Calculation:** Align 10 on the outer scale with the mile mark (▲) (or STAT mark) on the inner scale. The Km mark (▲) will point to 1.6 km on the outer scale. At the same time, the Knot mark (▲) (or NAUT mark (▲) = nautical mile) will point to approx. 86.6 knots (0.886 nautical miles) on the outer scale.

The conversion becomes 1 mile  $\hat{=}$  1.6 km  $\hat{=}$  0.86 knots.

# FITTING PROCEDURE OF HANDS

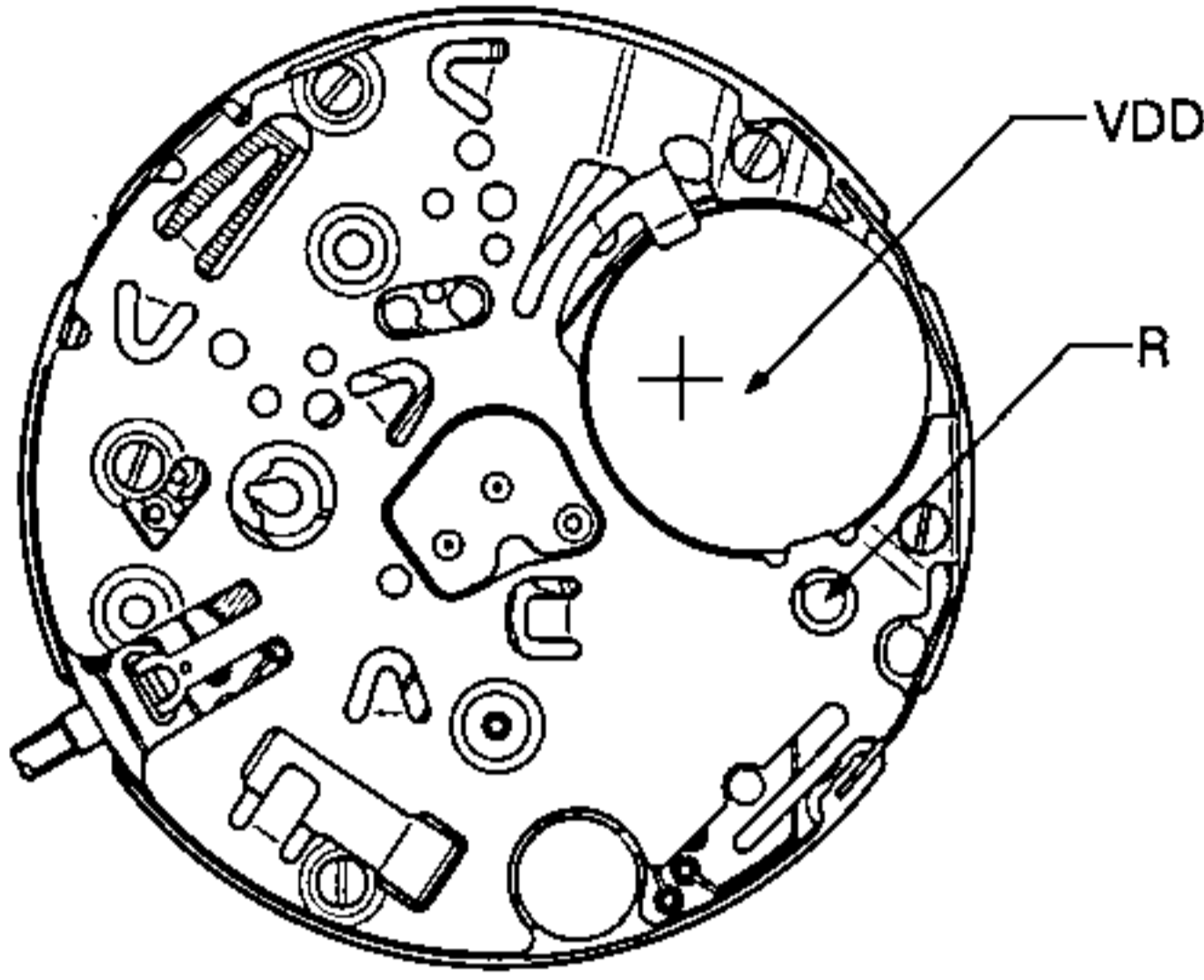
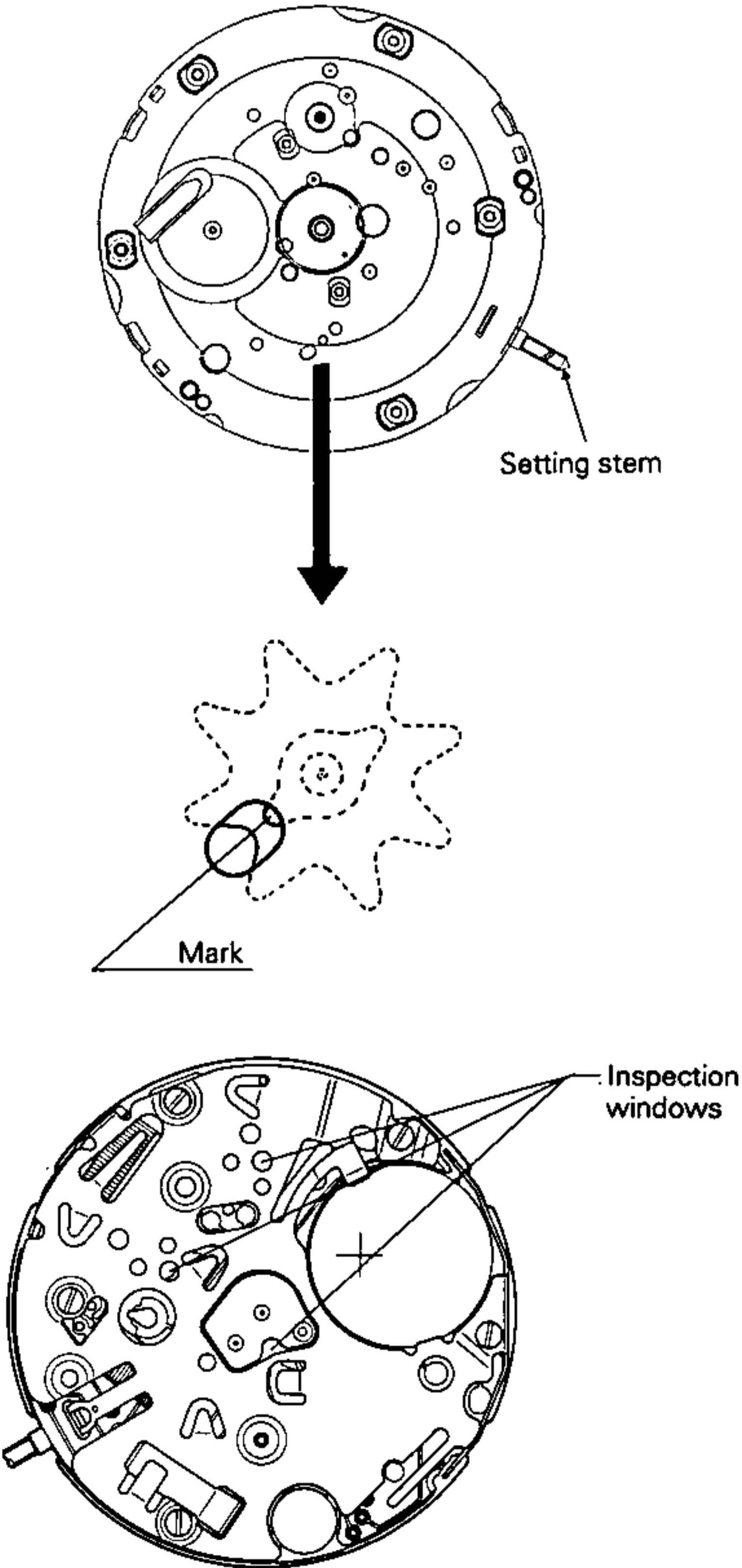
Step	Explanatory illustration	Remarks
<p>① Perform all reset. Perform the same procedure for 6800 and 6850.</p>		<p>Electrically connect position (+) side of power cell with (R) pattern for more than 2 seconds.</p>
<p>② Set module to "0" position confirmation mode. Perform the same procedure for 6800 and 6850.</p>		<p>a) Push the setting stem until the mark of the mode wheel is set as shown in the figure, watching through the inspection windows on the underside of the plate.</p> <p>b) Confirm that the train wheel is stopped, watching through the inspection windows on the train wheel bridge side. If it is moving, push the setting stem four times, then confirm the mode wheel mark again.</p> <p>* After setting, do not push the setting stem until the mode hand has been fitted.</p>

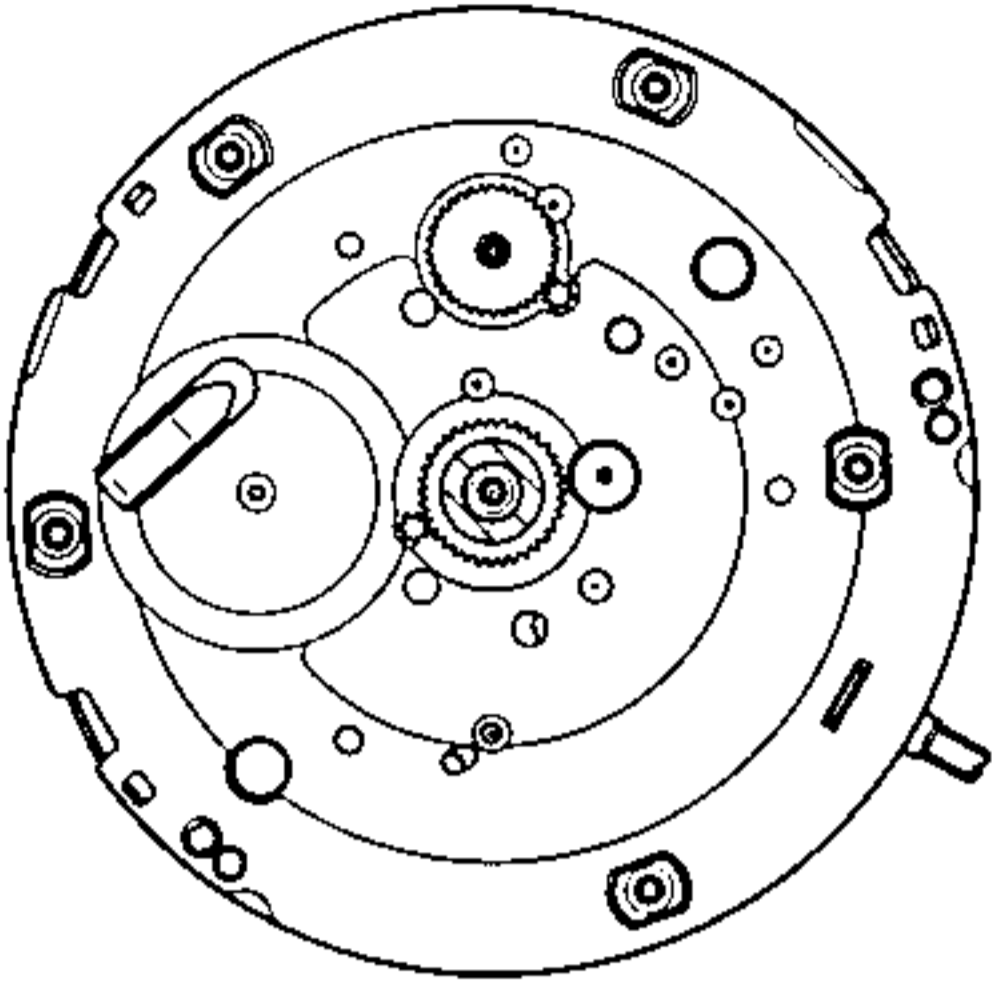
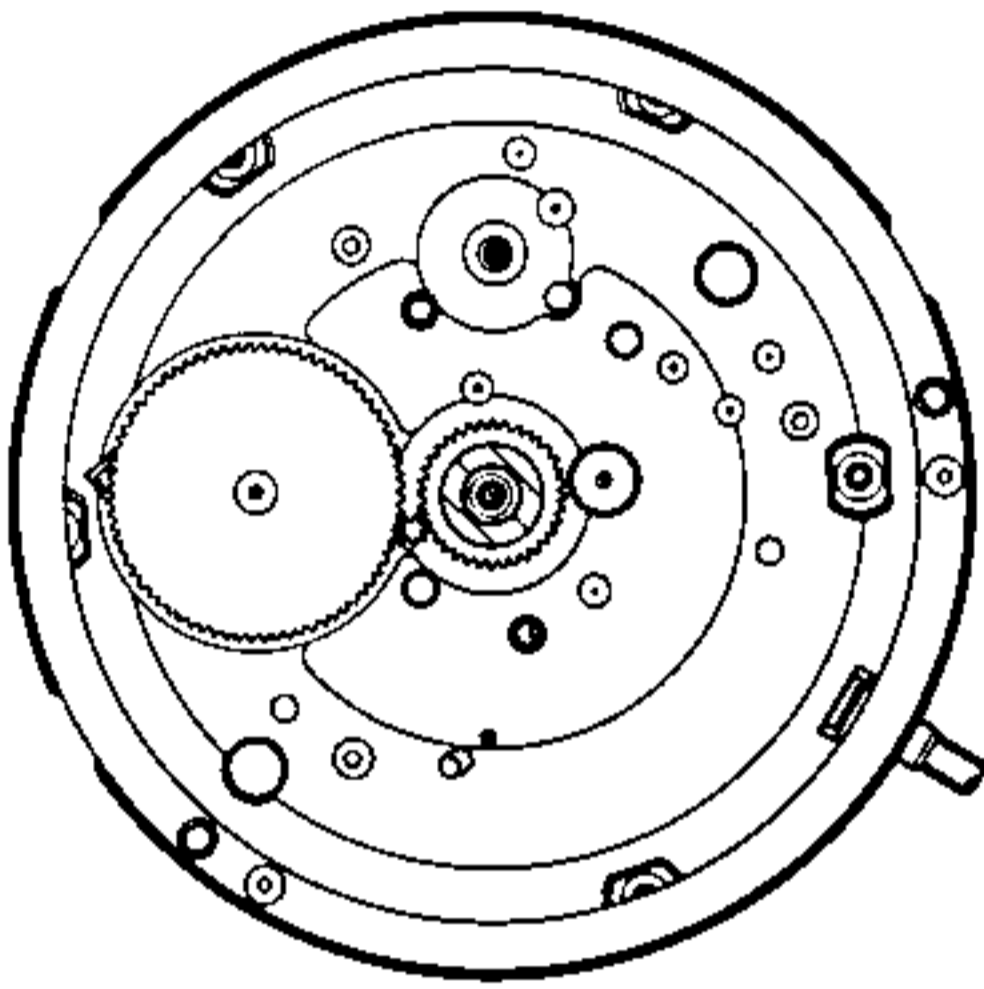
Step	Explanatory illustration	Remarks
<p>③ Install the hour wheels and related parts.</p>	<p>6800:</p>  <p>6850:</p> 	<p>6800: Install the hour wheel [I], dial washer [I], hour wheel [II], and dial washer [II].</p> <p>6850: Install the hour wheel and dial washer. At the same time, install the 24 hour wheel.</p>
<p>④ Install the dial. Perform the same procedure for 6800 and 6850.</p>		<p>Install the dial guard ring to the dial.</p>
<p>⑤ Install the hands.</p>		<p>6800: Install the sub-hour hand to any division. Pull out the switch stem. Push the ⓑ button to set the hour hand to 0 hour position (top of the dial).</p> <p>6850: Install the function hand to any division. Pull out the switch stem. Push the ⓑ button to set the function hand to 0 position (top of the dial).</p>

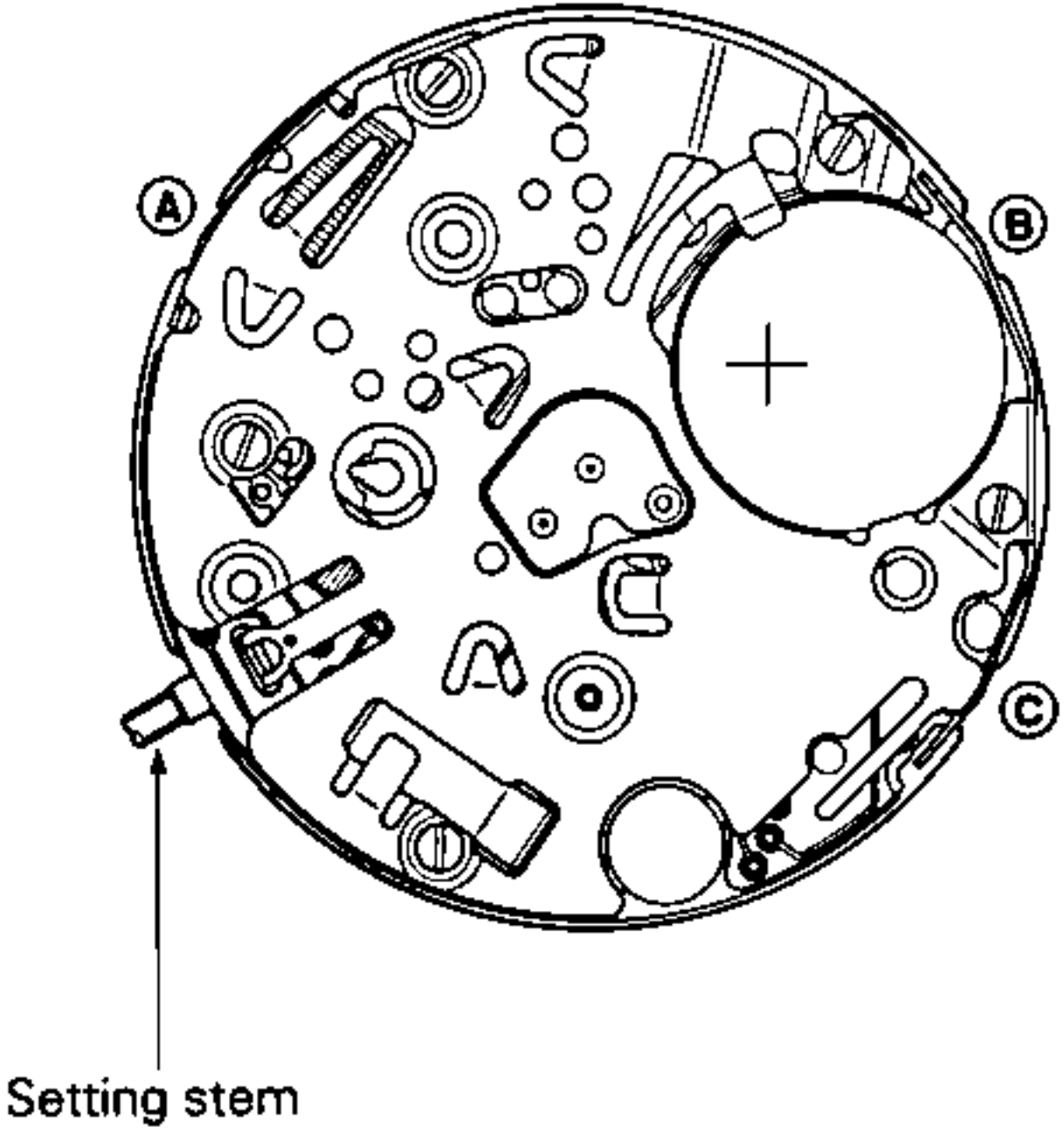
Step	Explanatory illustration	Remarks
<p>⑥ Confirm the 0 mode. "0" position confirmation mode. Perform the same procedure for 6800 and 6850.</p>	 <p>The illustration shows a top-down view of a watch movement. A central circular component has a crosshair. To its left is a rectangular component labeled 'Setting stem'. Three buttons are marked with circled letters: 'A' at the top left, 'B' at the top right, and 'C' at the bottom right. Various gears and mechanical parts are visible around the central area.</p>	<p>With the switch stem at the normal position, push any one of (A), (B), and (C) buttons to confirm the demonstrative movement of the sub-hour hand (6800) or the function hand (6850).</p> <p>* If the hand does not demonstrate: a) Push the switch stem one time. b) Push any one of (A), (B), and (C) buttons.</p> <p>Repeat a) and b) above until the hand demonstrates at b).</p>
<p>⑦ Install the mode hand. Perform the same procedure for 6800 and 6850.</p>		<p>Install the mode hand to the center of print of ► 0 ◀.</p>
<p>⑧ Install the hour and minute hands.</p>		<p>6800: Install the sub-hour and sub-minute hands to 0 hour position. Install the second hand to any division.</p> <p>6850: Install the hour and minute hands to 12 hour and 0 minute position. Install the 24-hour hand to 0 hour position. Install the second hand to any division.</p>

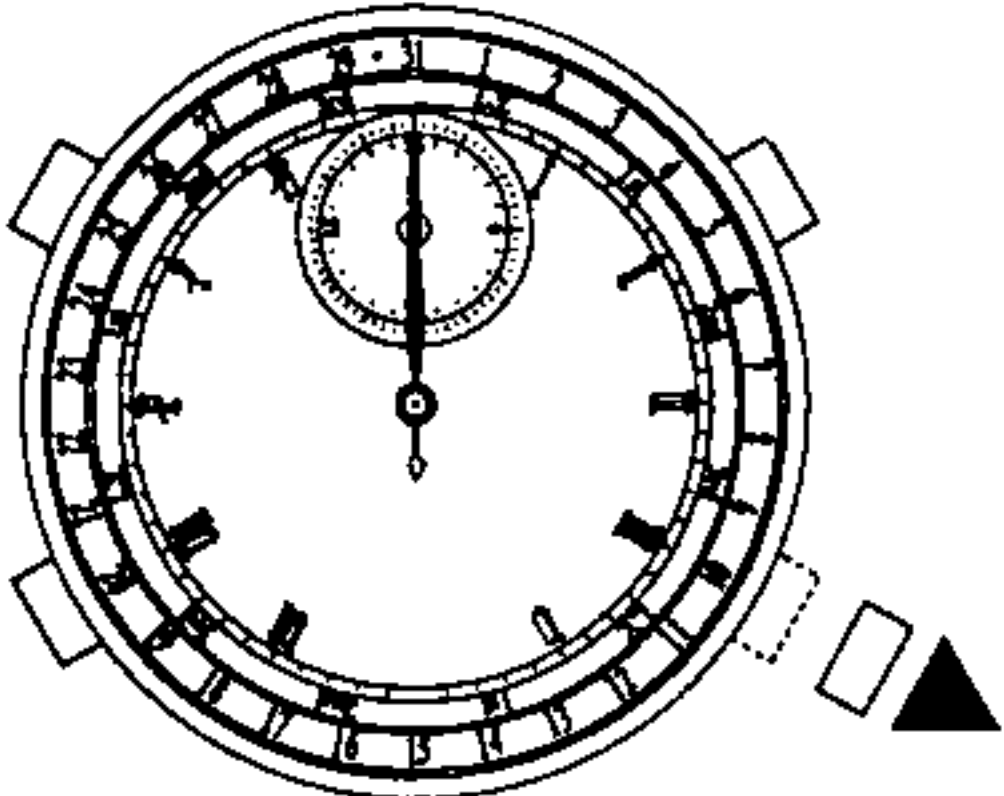
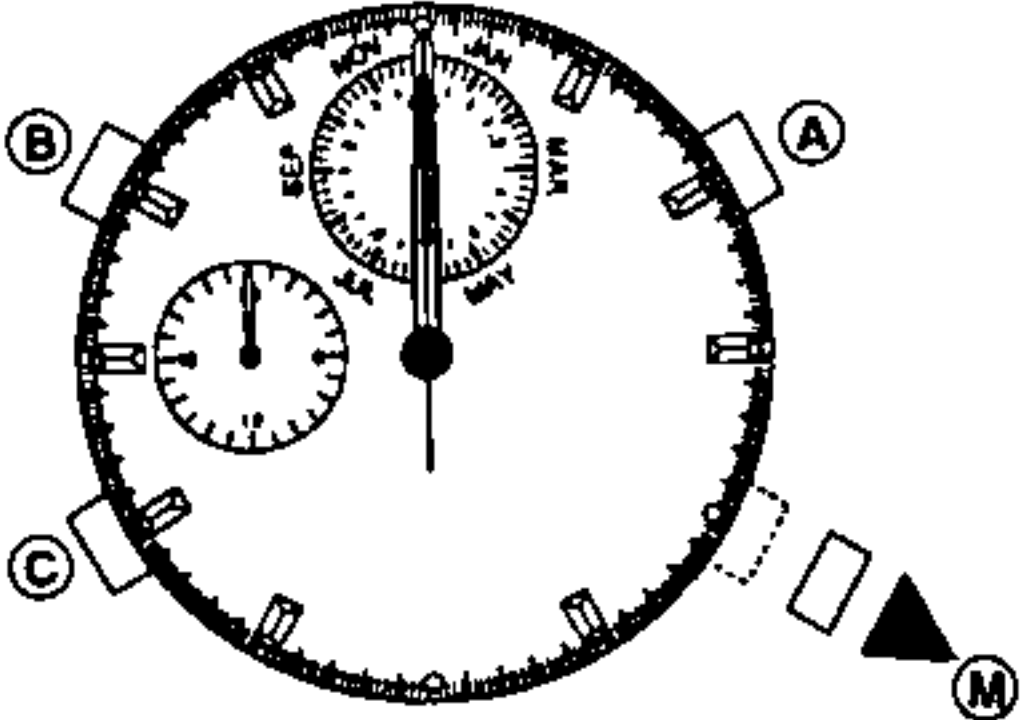

Step	Explanatory illustration	Remarks
<p>⑨ Install the module to the case. Perform the same procedure for 6800 and 6850.</p>		
<p>⑩ Perform "0-position setting".</p>	<p>6800:</p>  <p>6850:</p> 	<p>1) Pull the (M) button to first click step.</p> <p>2) Push the (A) button to set the second hand to 0 second position (top of the dial), and the (B) button to set the hour hand to 0 hour position (top of the dial), and the (C) button to set the minute hand to 0 minute position (top of the dial).</p> <p>3) Securely return the (M) button to the normal position.</p> <p>1) Pull the (M) button to the first click first step.</p> <p>2) Push the (A) button to set the second hand to 0 second position (top of the dial), and the (B) button to set the function hand to 0 position (top of the dial), and the (C) button to set all of the hour, minute, and 24-hour hands to 0 hour position (top of the dial).</p> <p>3) Securely return the (M) button to the normal position.</p>
<p>⑪ Set the watch to the present calendar and time.</p>		



## POWER CELL REPLACEMENT PROCEDURE

When replacing the power cell, be sure to measure the power consumption of the watch, without taking the module out of the case.

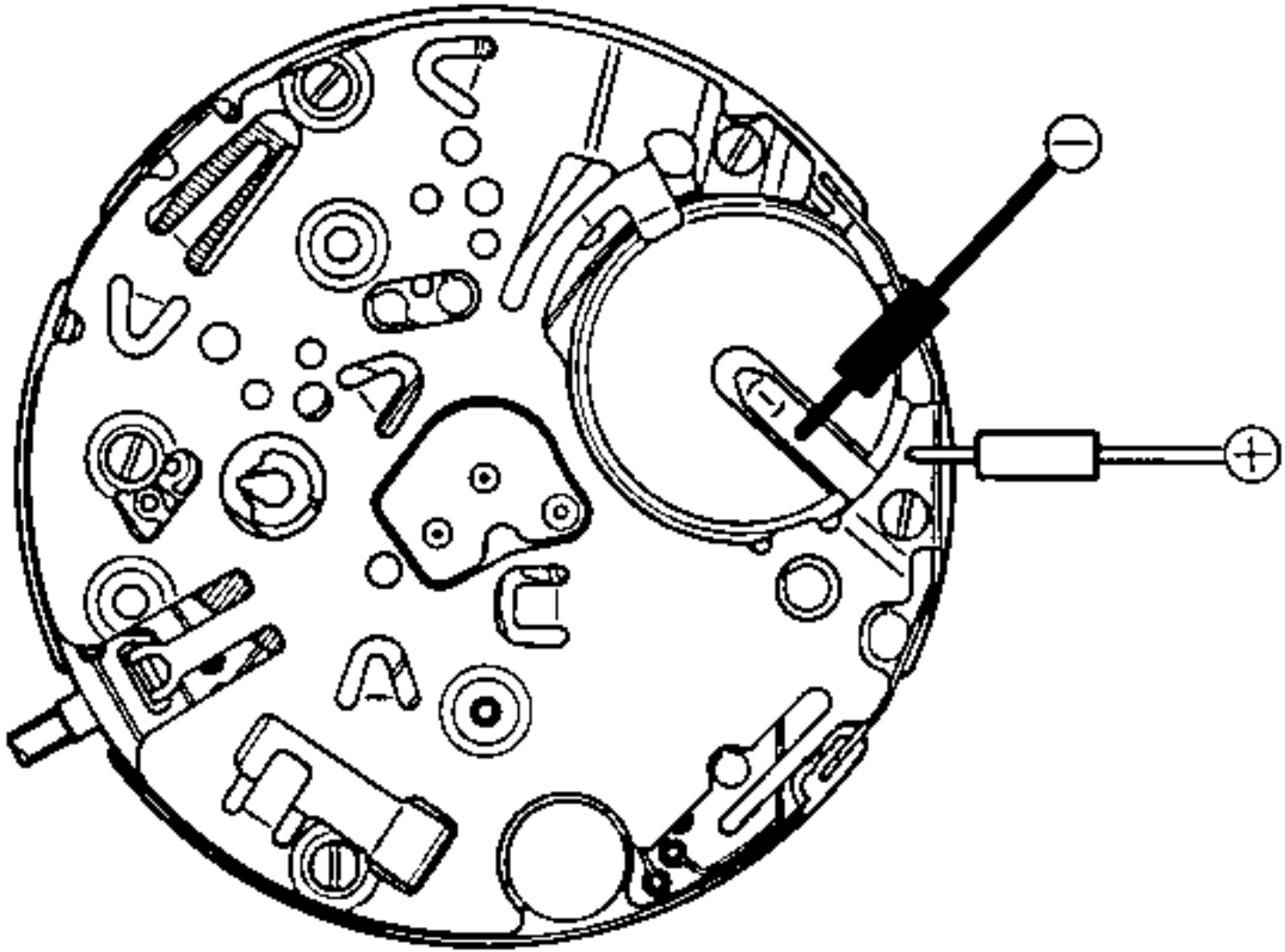
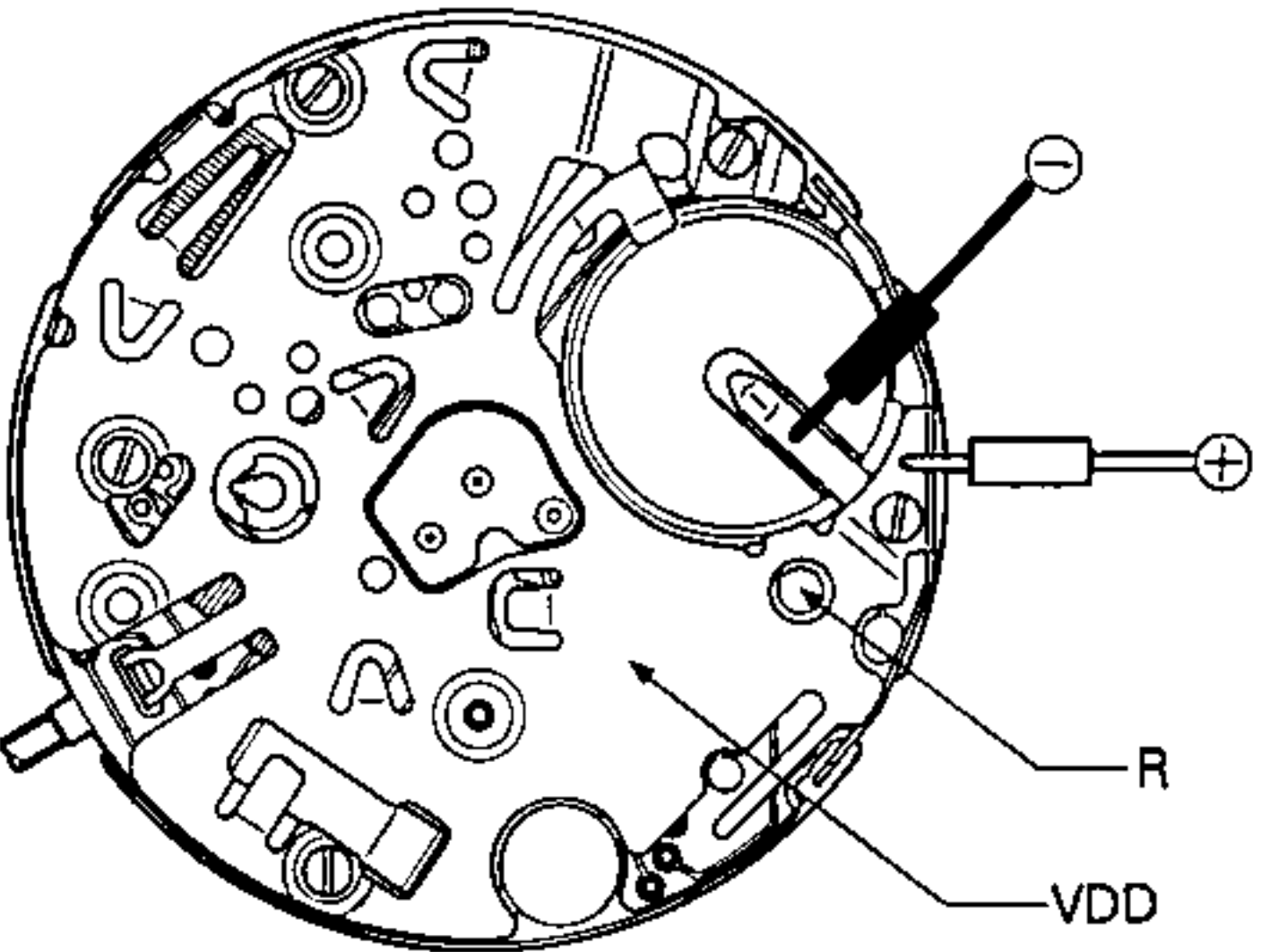
### I. MEASUREMENT OF CURRENT CONSUMPTION

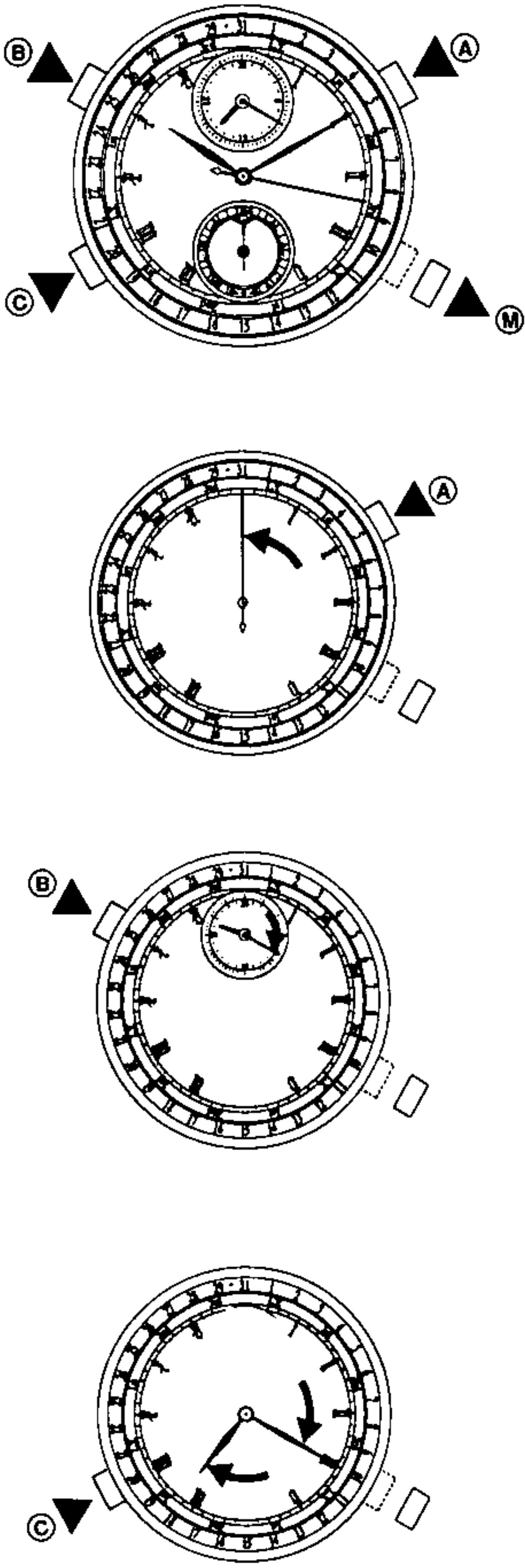

Step	Explanatory illustration	Remarks
<p>① Set the watch to the time mode.</p>		
<p>② Set the tester for measuring current consumption, and apply the lead bars of the tester to ⊕ and ⊖ of the module.</p>		<p>Keep the lead bars applied until the measurement is finished.</p> <p>⊕: Power cell strap ⊖: Power cell connector spring</p>
<p>③ Perform all reset.</p>		<p>Keep the lead bars applied, securely short the (R) terminal to power cell strap with pincers, etc. for more than 2 seconds.</p>
<p>④ Measure the current consumption.</p>	<p>* If there is any dirt or dust on any connecting part of the train wheel or circuit, the current consumption may be increased. Note this when measuring.</p>	<p>Read the current when the tester pointer is stabilized.</p> <p><b>2.0 μA max.</b> (Both 6800 and 6850) → OK</p>
<p>⑤ Operation after power cell replacement.</p>	<p>After the power cell is replaced, the information in the IC in the watch is wrong. Perform the "0-position setting" to make each function work correctly. (See ⑥ to ⑪ on following pages.)</p>	

## II.0-POSITION SETTING

Step	Explanatory illustration	Remarks
<p>① Set the watch to the 0-position confirmation mode. Perform the same procedure for 6800 and 6850.</p>	<p>6800: </p> <p>6850: </p>	
<p>② Perform the 0-position setting.</p>		<p>a) Pull the (M) button to the first click first step.</p> <p>b) Push and keep the (A), (B), and (C) buttons at the same time for more than 2 seconds.</p> <p>c) If the (A), (B), and (C) buttons are released, a peeping alarm sound comes and the sub-minute hand, minute hand, and second hand (6800) or the minute hand, second hand, and function hand (6850) move a little. After the above operation is confirmed, perform the "0-position setting".</p> <p>6800:</p> <p>d) Push the (A) button to set the second hand to 0 second position (top of the dial), and the (B) button to set the hour hand to 0 hour position (top of the dial), and the (C) button to set the minute hand to 0 minute position (top of the dial).</p> <p>e) Securely return the (M) button to the normal position.</p>

Step	Explanatory illustration	Remarks
	<p>The illustrations show the following steps:</p> <ol style="list-style-type: none"> <li>The watch is shown with buttons A, B, C, and M. Button A is at the 2 o'clock position, B at 10 o'clock, C at 8 o'clock, and M at 4 o'clock.</li> <li>The second hand is moved from its current position to the 12 o'clock position.</li> <li>The function hand is moved from its current position to the 12 o'clock position.</li> <li>The hour, minute, and 24-hour hands are moved to the 12 o'clock position.</li> </ol>	<p>6850:</p> <p>f) Push the (A) button to set the second hand to 0 second position (top of the dial), and the (B) button to set the function hand to 0 position (top of the dial), and the (C) button to set all of the hour, minute, and 24-hour hands to 0 hour position (top of the dial).</p> <p>g) Securely return the (M) button to the normal position.</p>

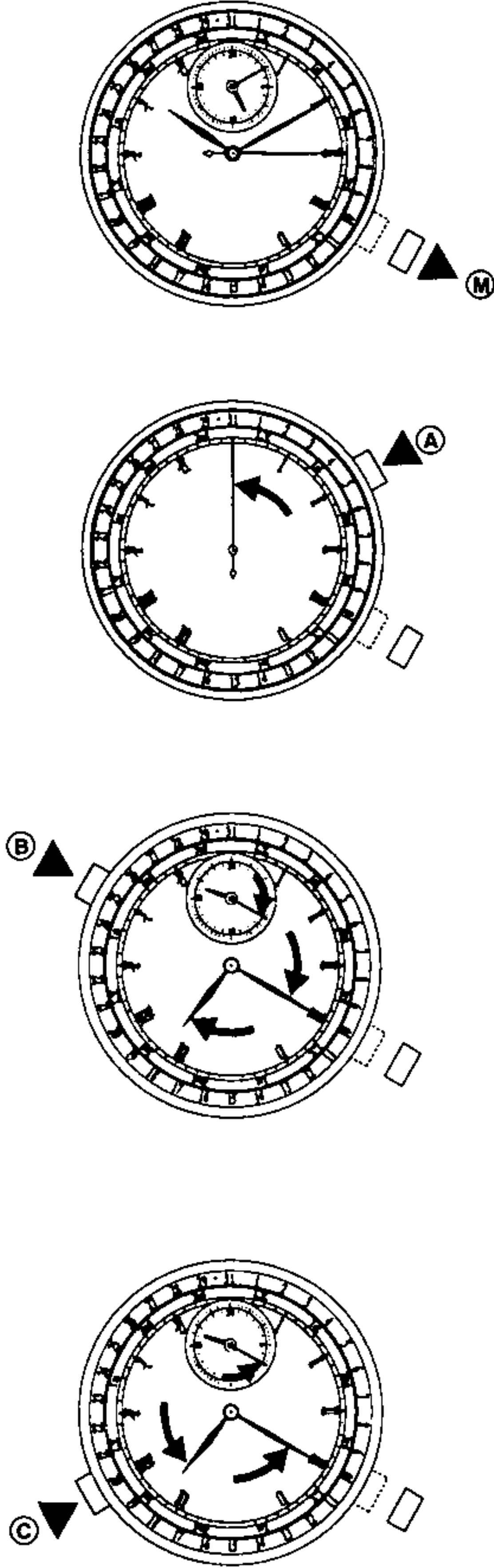

### III. SETTING THE PRESENT TIME

Step	Explanatory illustration	Remarks
<p>① Set the watch to the time mode. Perform the same procedure for 6800 and 6850.</p>	<p>6800: </p> <p>6850: </p>	
<p>② Set the watch to the present time.</p>	<p>6800:</p> 	<p>6800:</p> <p>a) Pull the <b>(M)</b> button to the first step.</p> <p>* The auxiliary time section which has been indicating the local time indicates the home time of 24-hour system.</p> <p>b) Push the <b>(A)</b> button to return the second hand to 0.</p> <p>* When the <b>(A)</b> button is pushed, the minute hand moves as follows according to the position of the second hand.</p> <p>0 – 29 seconds: Minute hand does not advance.</p> <p>30 – 59 seconds: Minute hand moves by 1 minute.</p> <p>c) The hour hand and minute hand can be corrected <b>clockwise</b> with the <b>(B)</b> button.</p> <p>d) The hour hand and minute hand can be corrected <b>counter clockwise</b> with the <b>(C)</b> button.</p> <p>e) Securely return the <b>(M)</b> button to the normal position.</p>

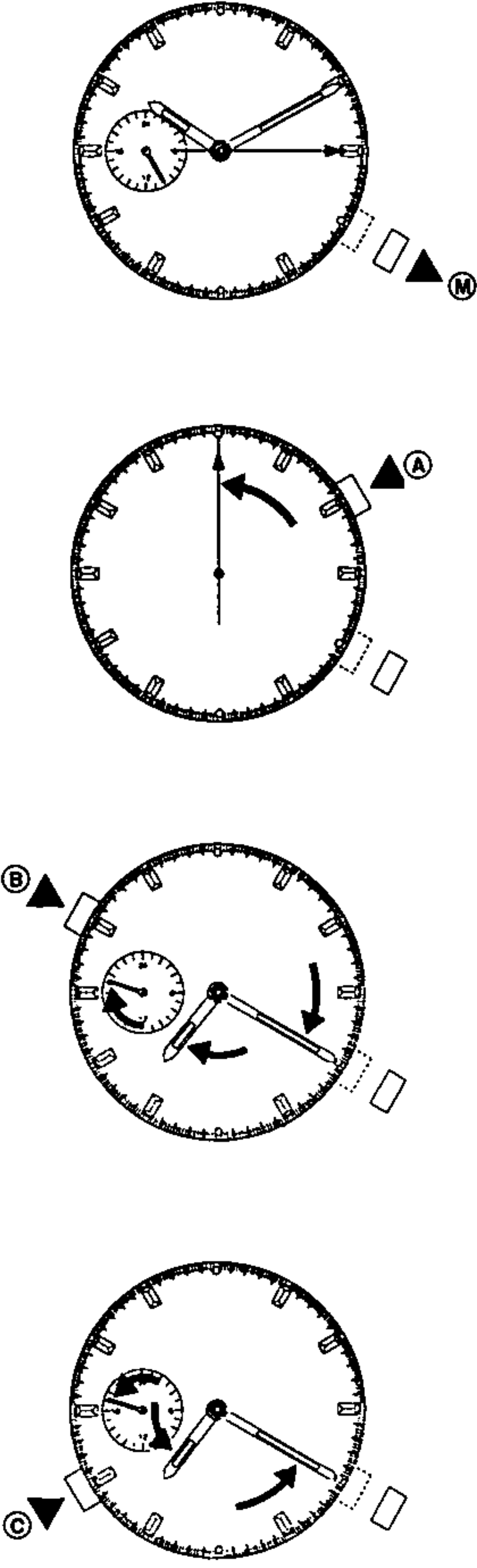

Step	Explanatory illustration	Remarks
	<p data-bbox="534 371 623 405">6850:</p>  <p>The illustrations show a watch face with a sub-dial at 9 o'clock. In the first diagram, the crown is pulled out to the first step (M). In the second, the crown is pushed back to the second step (A), and the second hand is shown moving to the 0 position. In the third, the crown is pushed back to the third step (B), and the hour and minute hands are shown moving clockwise. In the fourth, the crown is pushed back to the fourth step (C), and the hour and minute hands are shown moving counter-clockwise.</p>	<p data-bbox="1425 371 1514 405">6850:</p> <p data-bbox="1425 411 1815 486">a) Pull the (M) button to the first step.</p> <p data-bbox="1425 526 1873 601">b) Push the (A) button to return the second hand to 0.</p> <p data-bbox="1425 641 1852 798">c) The hour hand and minute hand can be corrected <b>clockwise</b> with the (B) button.</p> <p data-bbox="1425 837 1877 994">d) The hour hand and minute hand can be corrected <b>counter clockwise</b> with the (C) button.</p> <p data-bbox="1425 1034 1783 1158">e) Securely return the (M) button to the normal position.</p>

#### IV. SETTING THE PRESENT CALENDAR

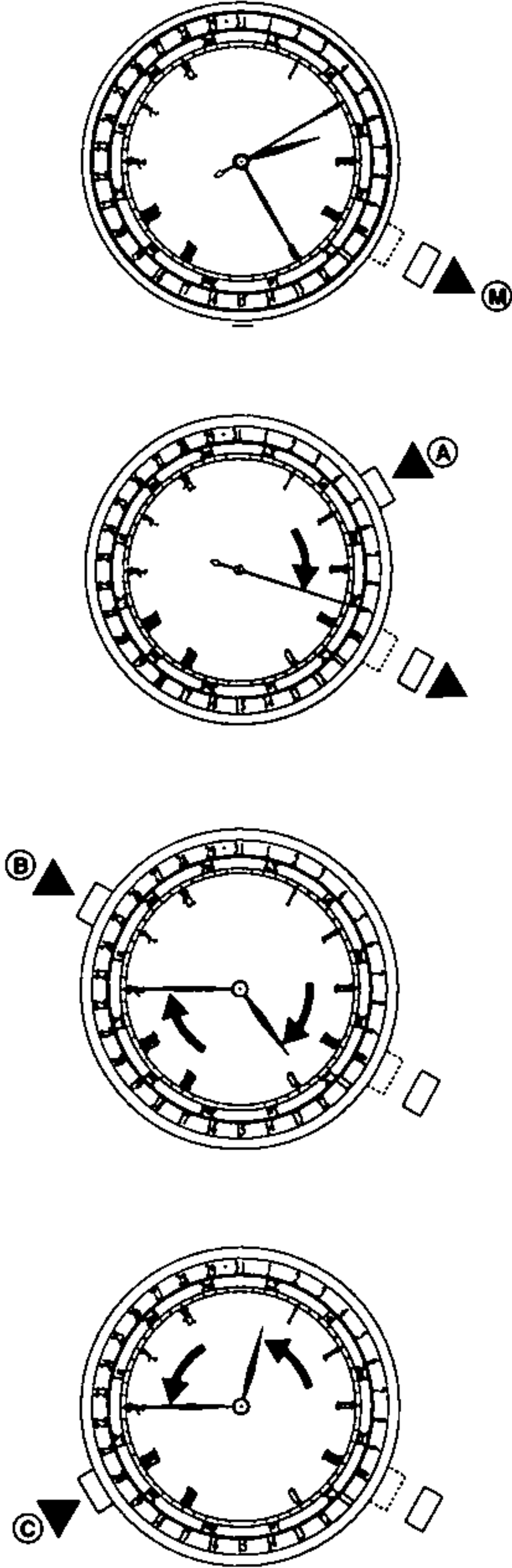
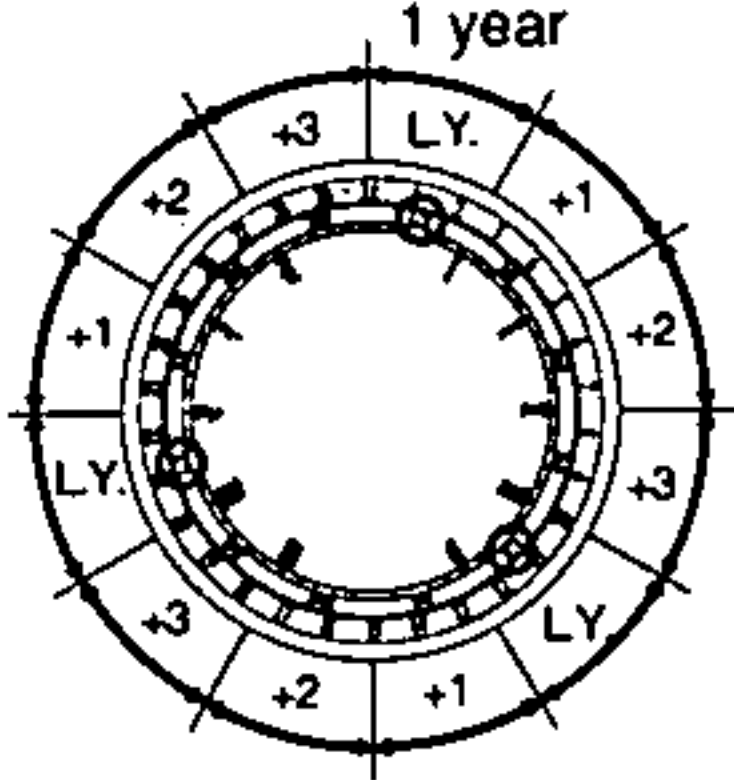
Step	Explanatory illustration	Remarks
<p>① Set the watch to the calendar mode. Perform the same procedure for 6800 and 6850.</p>	<p>6800: </p> <p>6850: </p>	<p>6800: Second hand .... Date hand Hour hand ..... Year hand (Number of years after leap year) Minute hand .... Month hand</p> <p>6850: Function hand... Month hand Second hand .... Date hand</p>
<p>② Set the watch to the present calendar.</p>	<p>6800:</p> 	<p>6800:</p> <p>a) Pull out the (M) button.</p> <p>b) Correct the date hand with the (A) button.</p> <p>* Set the hand to the date division on periphery of the dial.</p> <p>c) Correct the year and month hands <b>clockwise</b> with the (B) button.</p> <p>d) Correct the year and month hands <b>counter clockwise</b> with the (C) button.</p> <p>* This watch indicates the number of years after a leap year with the hour hand at the ratio of 1 hour to 1 year. Accordingly, there are three each of LY, +1, +2, and +3 on the dial. Use the mark which is the nearest to the year hand.</p>  <p>e) Securely return the (M) button to the normal position.</p>

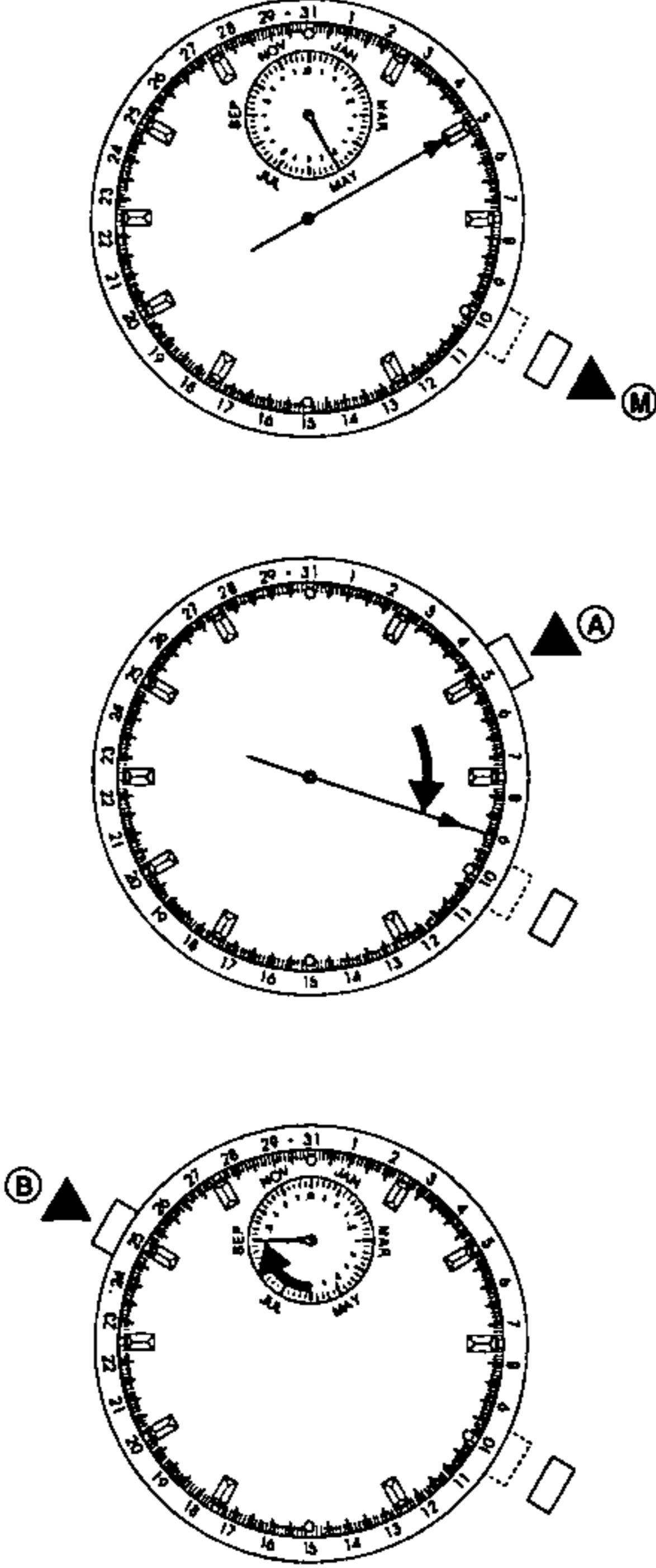
Step	Explanatory illustration	Remarks
	<p data-bbox="534 356 621 393">6850:</p> 	<p data-bbox="1425 356 1512 393">6850:</p> <p data-bbox="1425 399 1781 435">a) Pull out the (M) button.</p> <p data-bbox="1425 477 1854 556">b) Correct the date hand with the (A) button.</p> <p data-bbox="1425 598 1844 713">* Set the hand to the date division on periphery of the dial.</p> <p data-bbox="1425 756 1813 834">c) Correct the month hand with the (B) button.</p> <p data-bbox="1425 876 1781 991">d) Securely return the (M) button to the normal position.</p>

## PRECAUTIONS FOR DISASSEMBLING AND ASSEMBLING

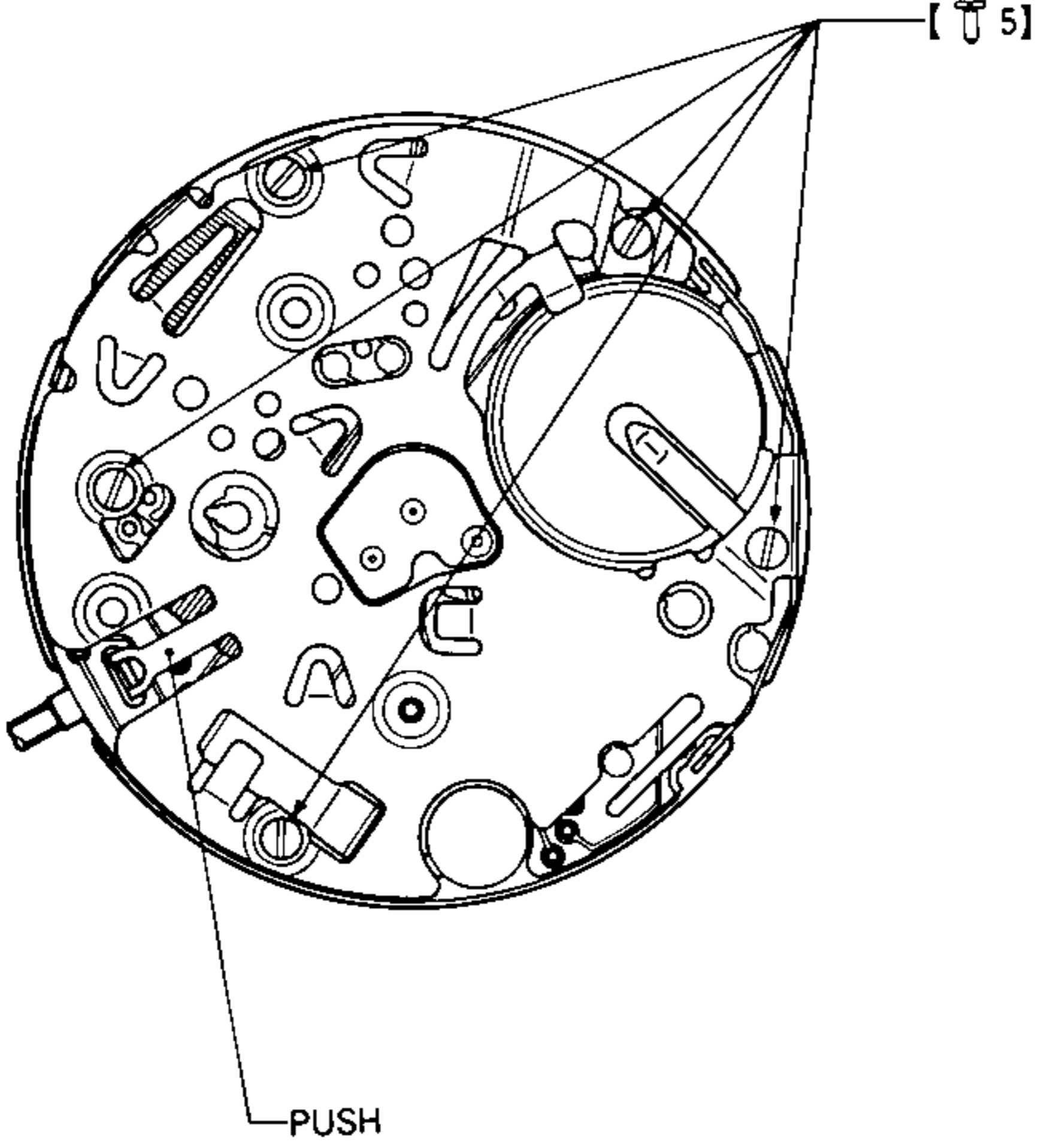
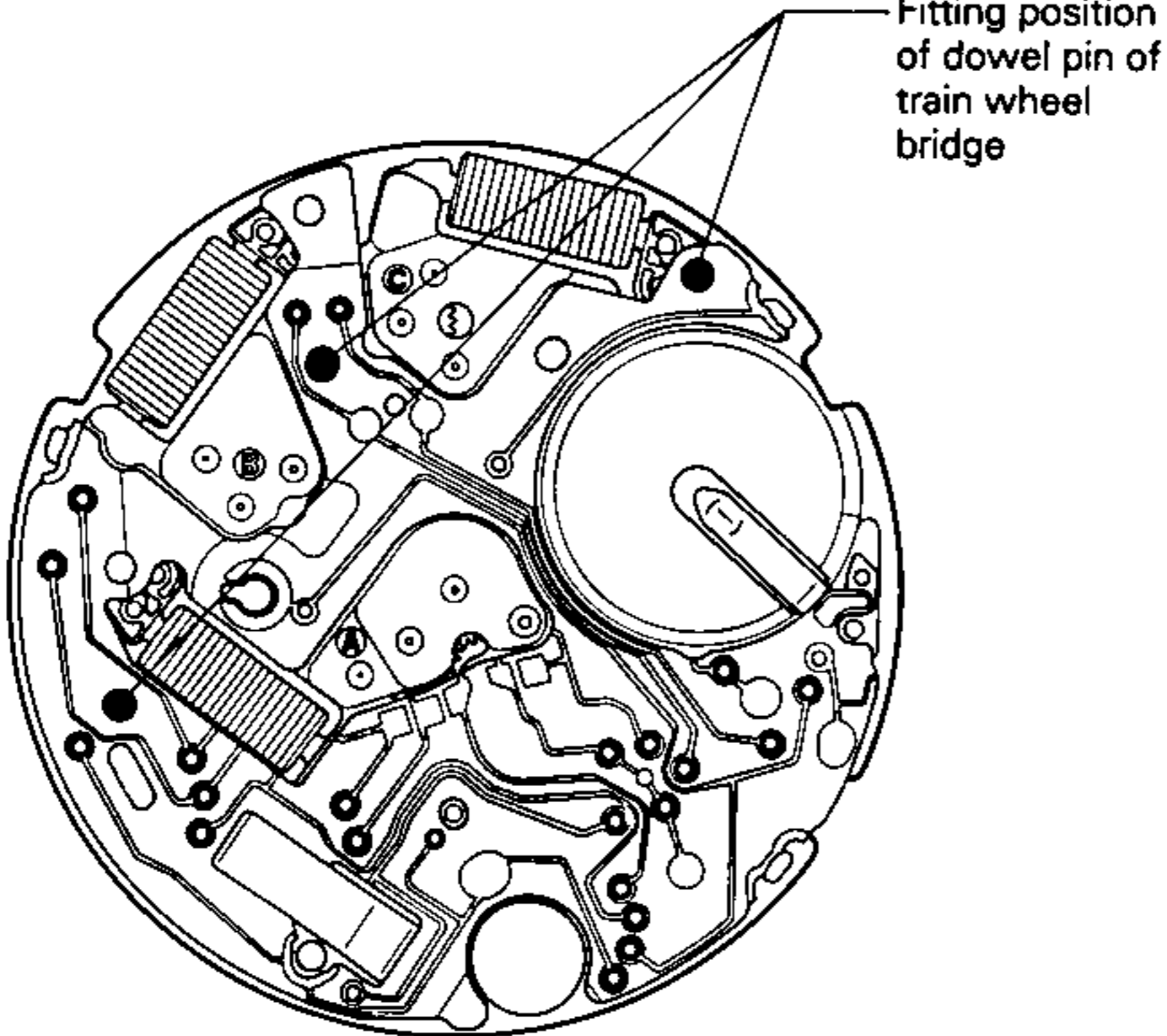
Disassembling procedure	Precautions
<p>Perform the same procedure for 6800 and 6850.</p> 	<ol style="list-style-type: none"> <li>1) Remove the power cell.</li> <li>2) Remove the five mounting screws of the power cell strap.</li> </ol> <p>*Note that the following items are removed if these screws are removed.</p> <ol style="list-style-type: none"> <li>3) Press the illustrated portion of the power cell strap and pull out the setting stem.</li> <li>4) Remove the power cell strap.</li> </ol>
<p>Perform the same procedure for 6800 and 6850.</p> 	<ol style="list-style-type: none"> <li>1) Remove the unit of electronic circuit.</li> </ol> <p>*The unit of electronic circuit is fitted to the dowel pin of the train wheel bridge. Since the train wheel bridge is not secured with any screw, press it when removing the unit of electronic circuit.</p>

**Disassembling procedure**

**Precautions**

Perform the same procedure for 6800 and 6850.

1) The "mode changeover switch spring" is fitted to the two dowel pins of the mode wheel.

\*When assembling, confirm that the two hole of the mode changeover switch spring are fitted to the two dowel pins of the mode wheel.

Fitting direction of the mode changeover switch spring is shown below.

Train wheel bridge

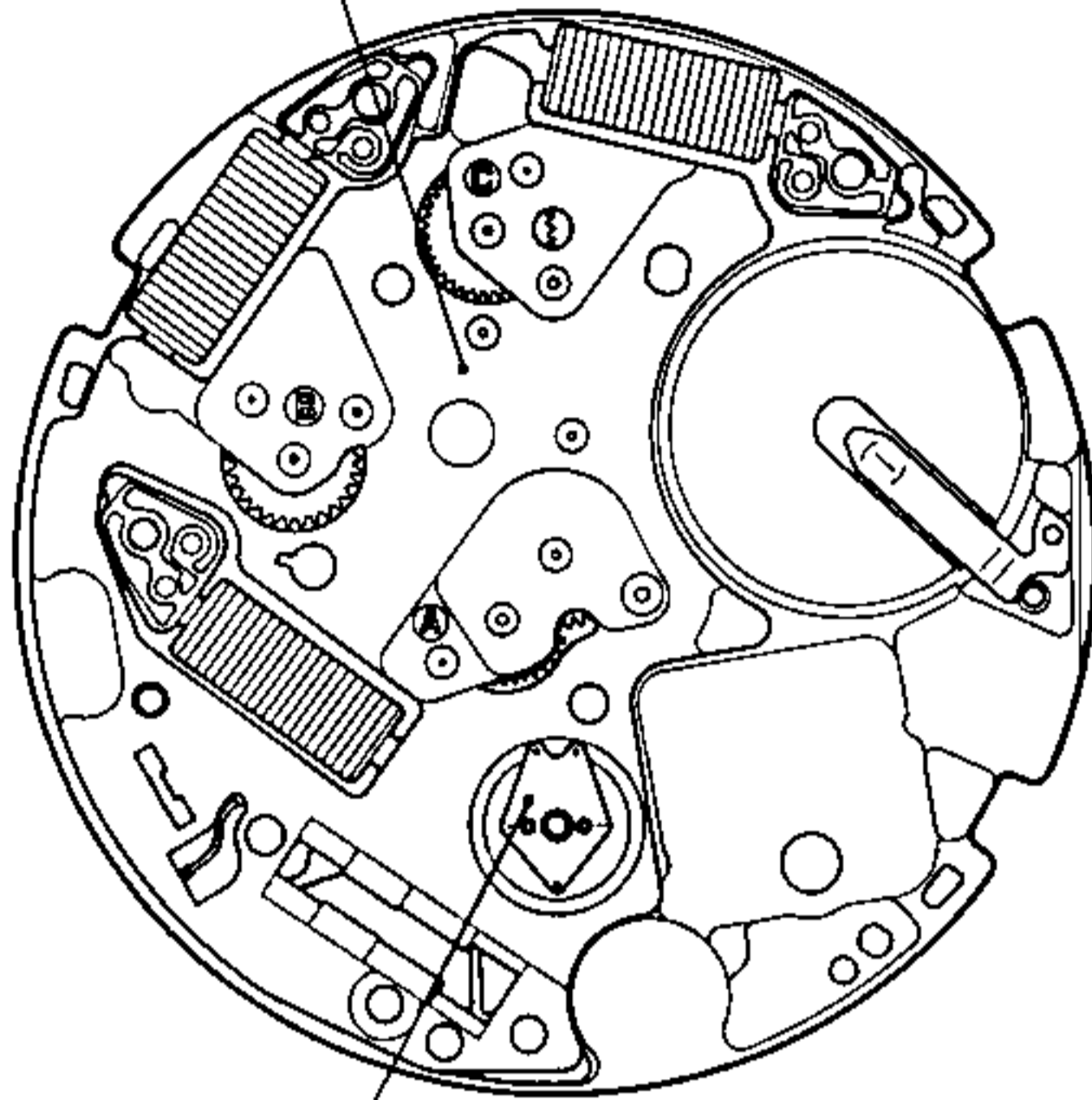

Mode changeover switch spring

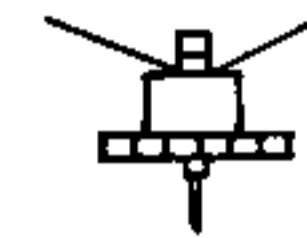

6800:

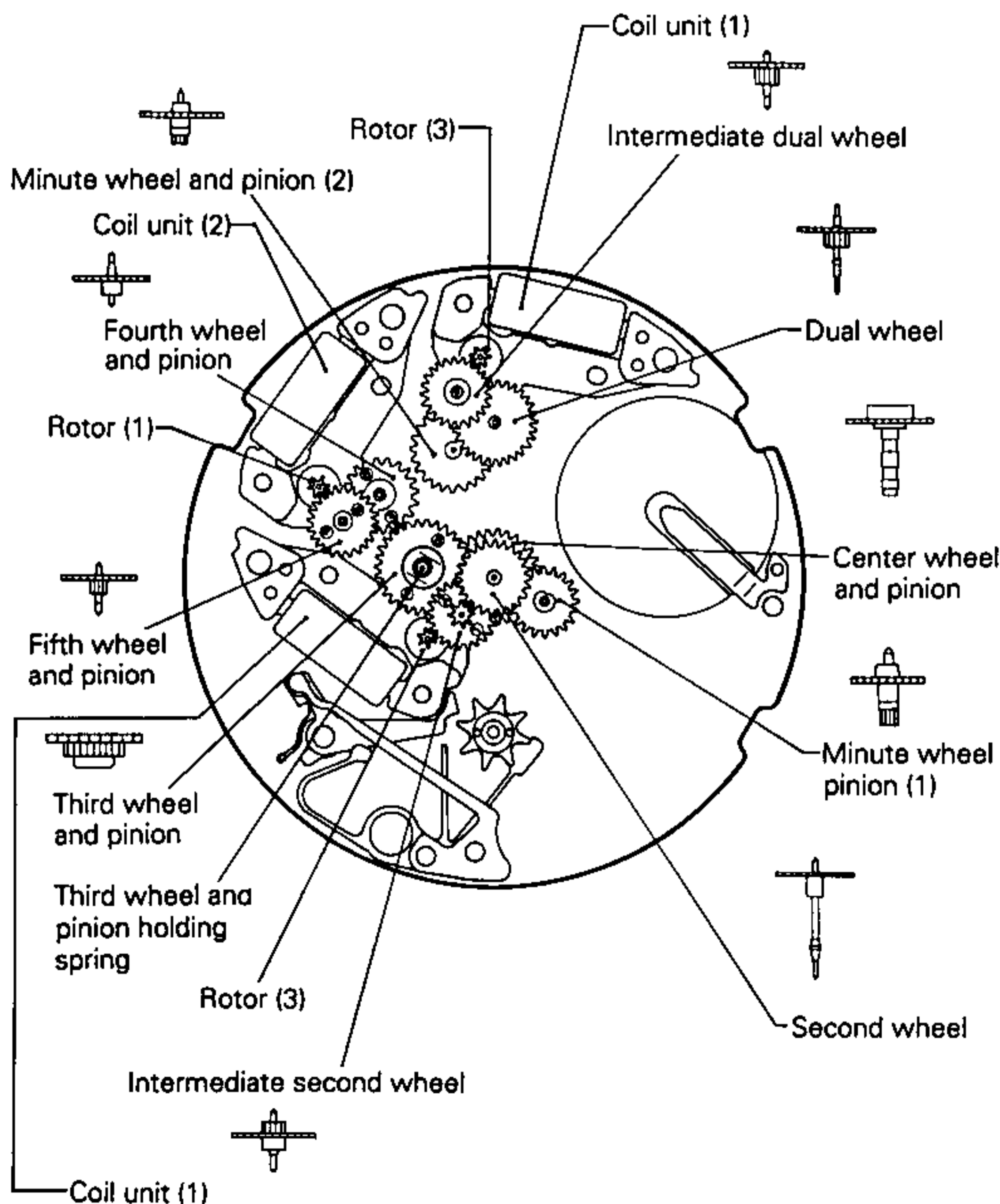



1) The train wheel is divided into train wheel A, B, and C. Identification marks of A1 and B2 – B4 are stamped on the them from the center wheel and pinion and second wheel and pinion at the center to the rotor. The train wheel C and minute wheel and pinion (1) do not have any identification mark.

Rotor (1) (Pinion):	White,
(Washer):	Gold
Rotor (3) (Pinion):	White,
(Washer):	White
Coil unit (1):	Red
Coil unit (2):	Blue

2) Fit the third wheel and pinion holding spring to the top of the third wheel and pinion as shown below.



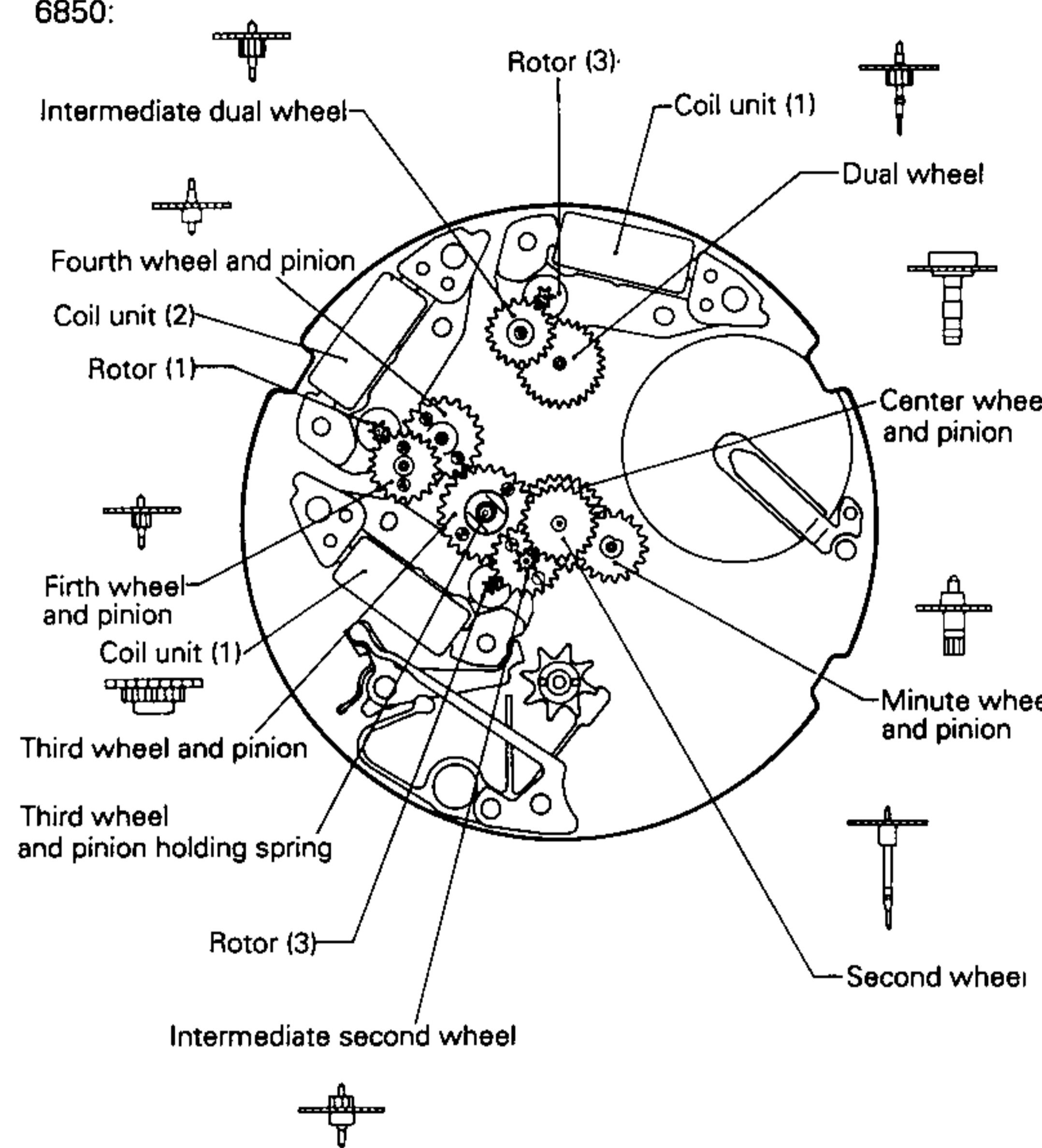

Disassembling procedure	Precautions
<p>6850:</p>  <p>Intermediate dual wheel</p> <p>Fourth wheel and pinion</p> <p>Coil unit (2)</p> <p>Rotor (1)</p> <p>Fifth wheel and pinion</p> <p>Coil unit (1)</p> <p>Third wheel and pinion</p> <p>Third wheel and pinion holding spring</p> <p>Rotor (3)</p> <p>Intermediate second wheel</p> <p>Rotor (3)</p> <p>Coil unit (1)</p> <p>Dual wheel</p> <p>Center wheel and pinion</p> <p>Minute wheel and pinion</p> <p>Second wheel</p>	<p>6850:</p> <p>1) The train wheel is divided into train wheel A, B, and C. Identification marks of A1 and B2 – B4 are stamped on the them from the center wheel and pinion and second wheel and pinion at the center to the rotor. The train wheel C and minute wheel and pinion do not have any identification mark.</p> <p>Rotor (1) (Pinion): White, (Washer): Gold</p> <p>Rotor (3) (Pinion): White, (Washer): White</p> <p>Coil unit (1): Red</p> <p>Coil unit (2): Blue</p> <p>2) Fit the third wheel and pinion holding spring to the top of the third wheel and pinion as shown below.</p> 

## 4 DISASSEMBLY AND ASSEMBLY OF THE MODULE

\* These illustrations are based on Cal. 6820.

● Lubrication narjubgs

- ⊕ : A-Lube oil
- ⊖ : V-Lube oil
- ∞ : CH-1 oil
- ⊙ : F-Lube oil

Disassemble procedure ① → ⑳  
 Assemble procedure ⑳ → ①

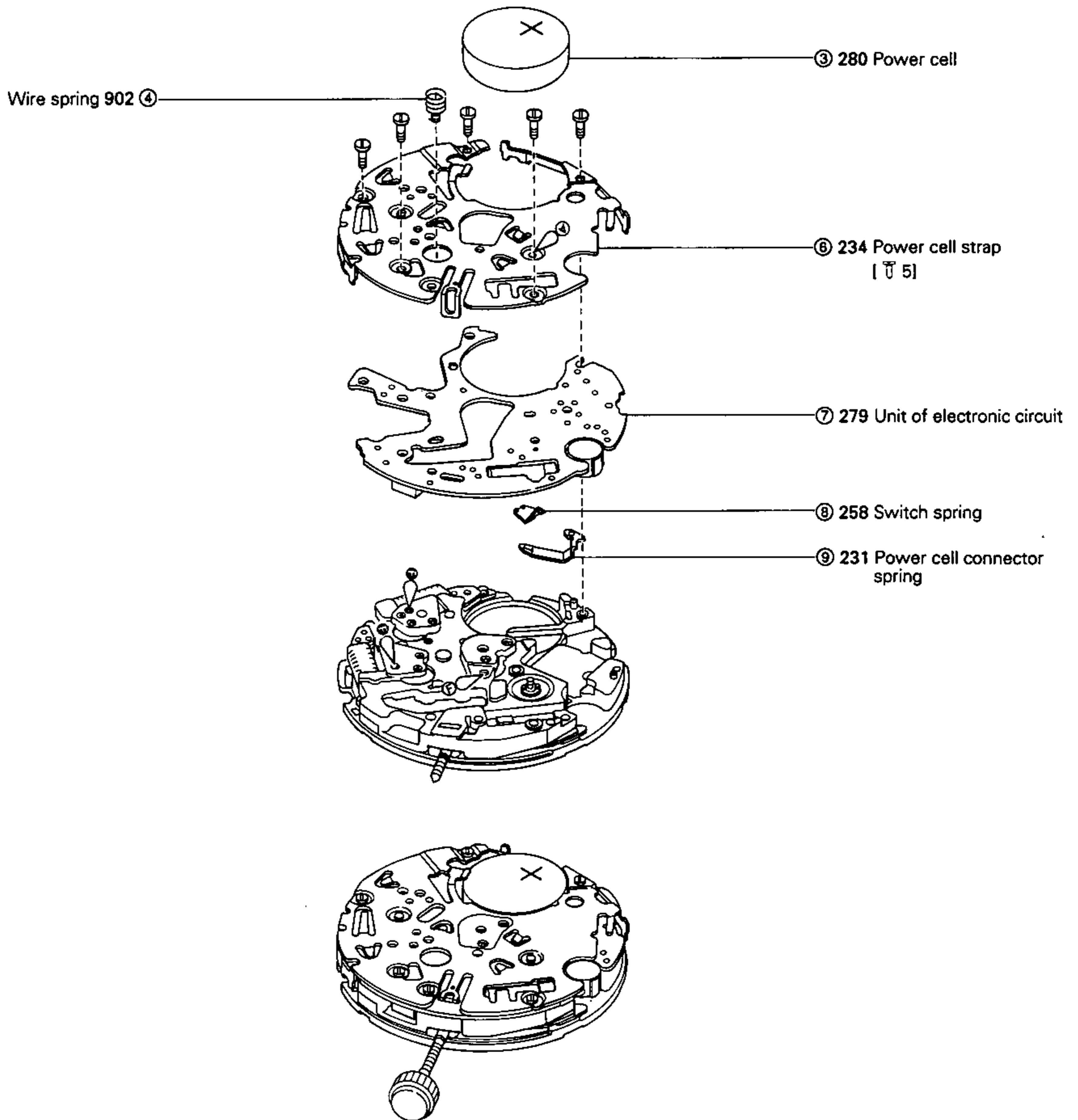

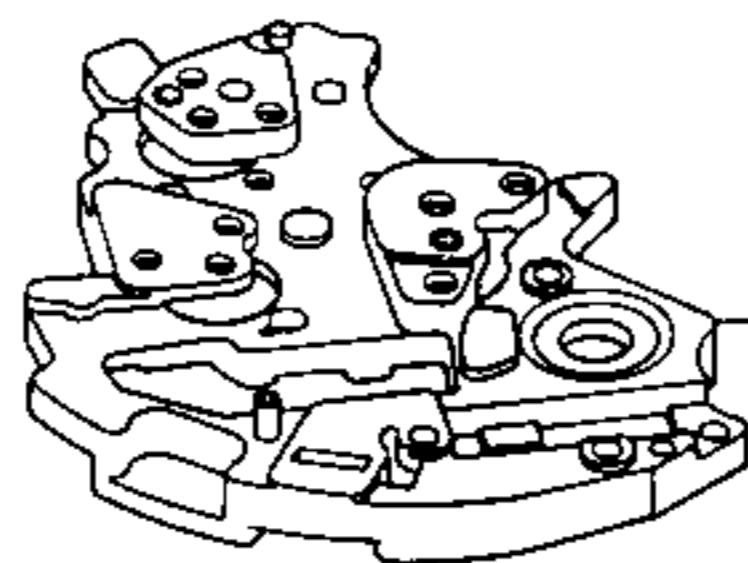

⑩ 701 Train wheel bridge

⑪ 025 Center wheel axle

⑭ 294 Dual wheel

⑰ 023 Fourth wheel and pinion

⑱ 012 Center wheel and pinion

⑲ 285-113 Rotor (1)

⑳ 255 Mode wheel

㉑ 227 Switch actuating spring

㉒ 109 Mode jumper

㉓ 165 Rocking bar

㉔ 903 Switch spring

② 075 Hour wheel

① 078 Dial washer

Third wheel and pinion 017 ⑫

Intermediate dual wheel 084-53 ⑬

Fifth wheel and pinion 084-55 ⑮

Intermediate hour wheel 100 ⑮

Rotor (3) 285-119 ㉑

Rotor (2) 285-115 ㉒

Coil unit (1) 246-136 ㉓

Coil unit (2) 246-139 ㉔

Stator 190 ㉕

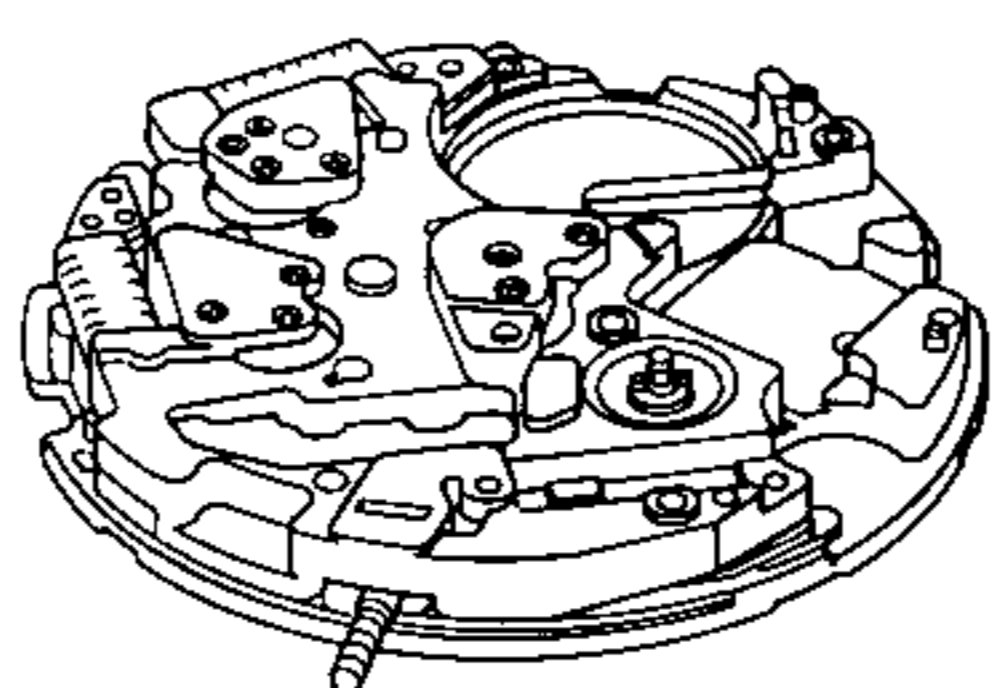
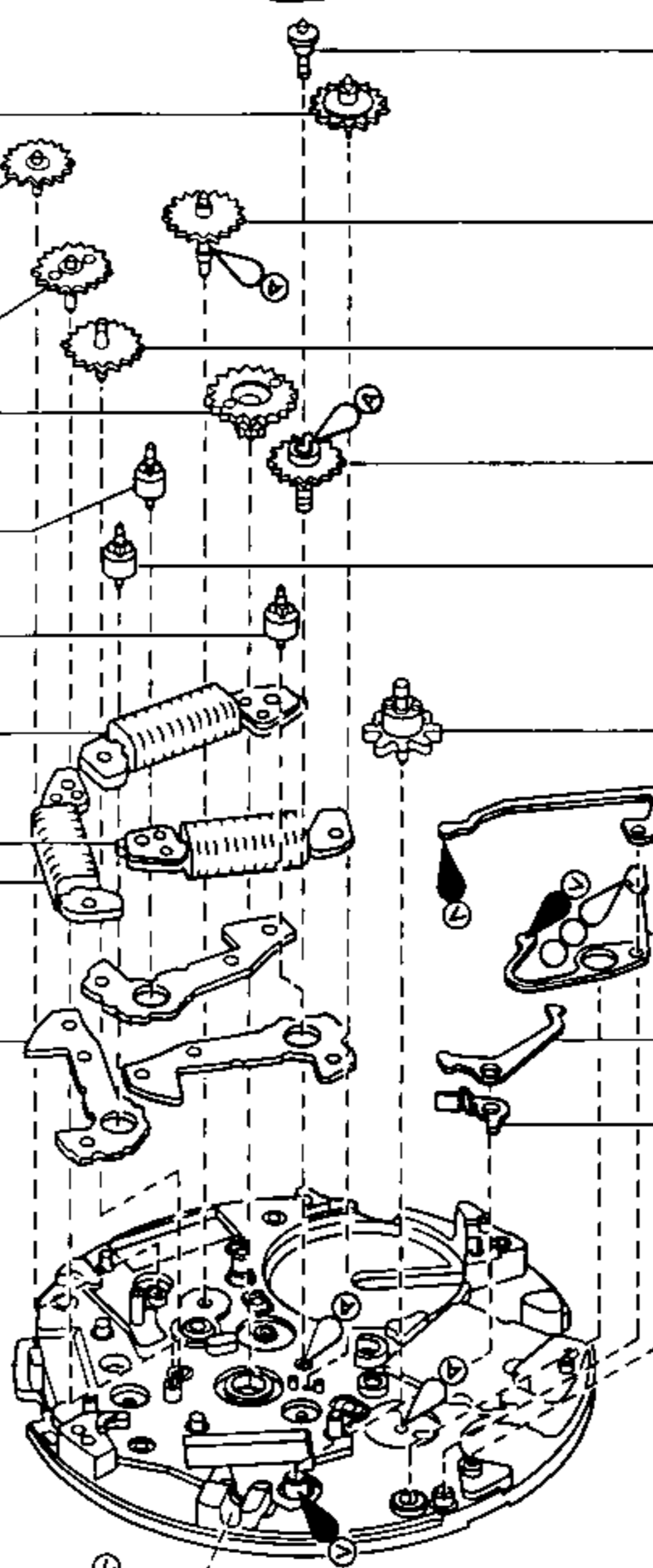

Setting stem 065 ⑤

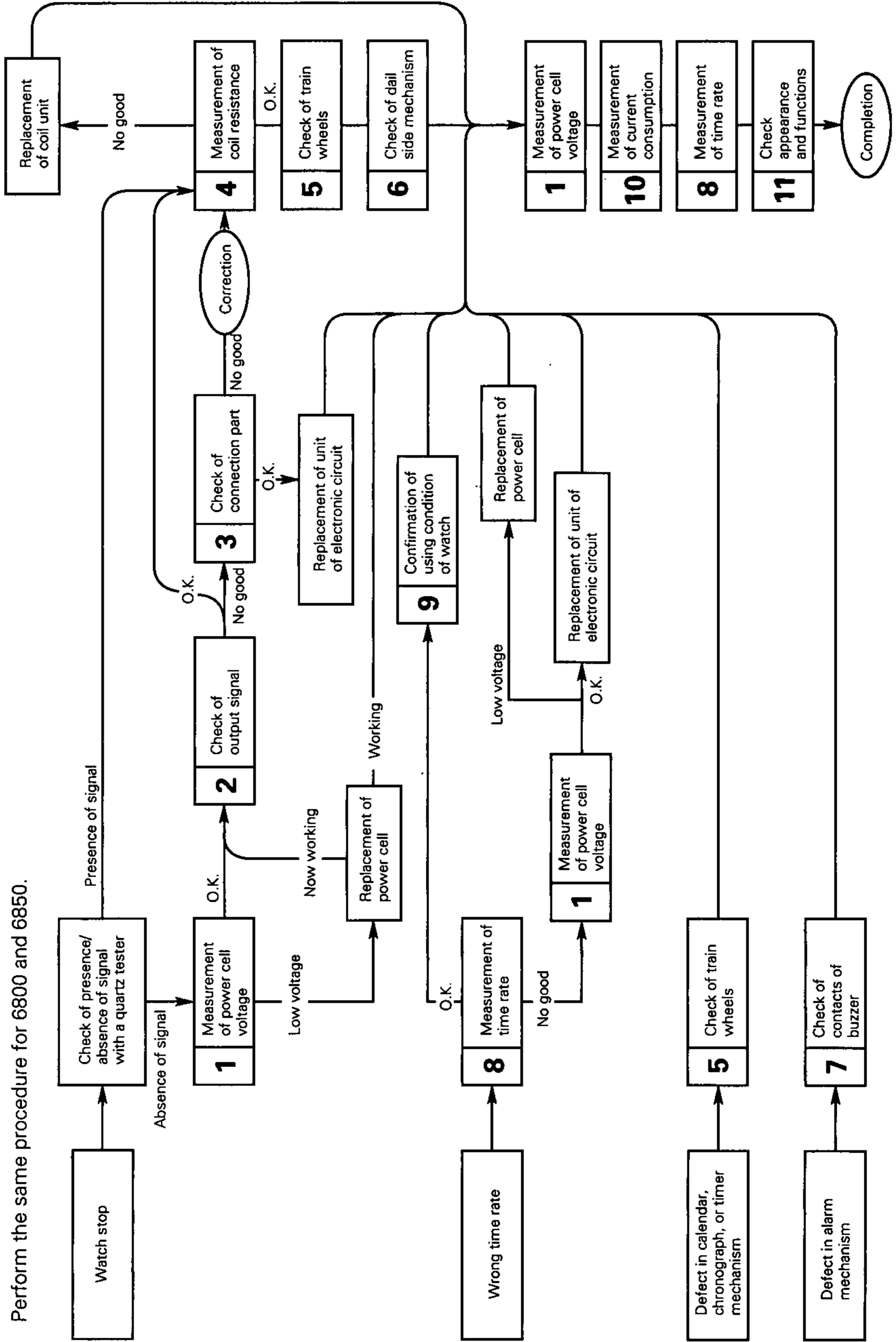

## 5 INSPECTION AND ADJUSTMENT METHOD OF MODULE

Perform the same procedure for 6800 and 6850.

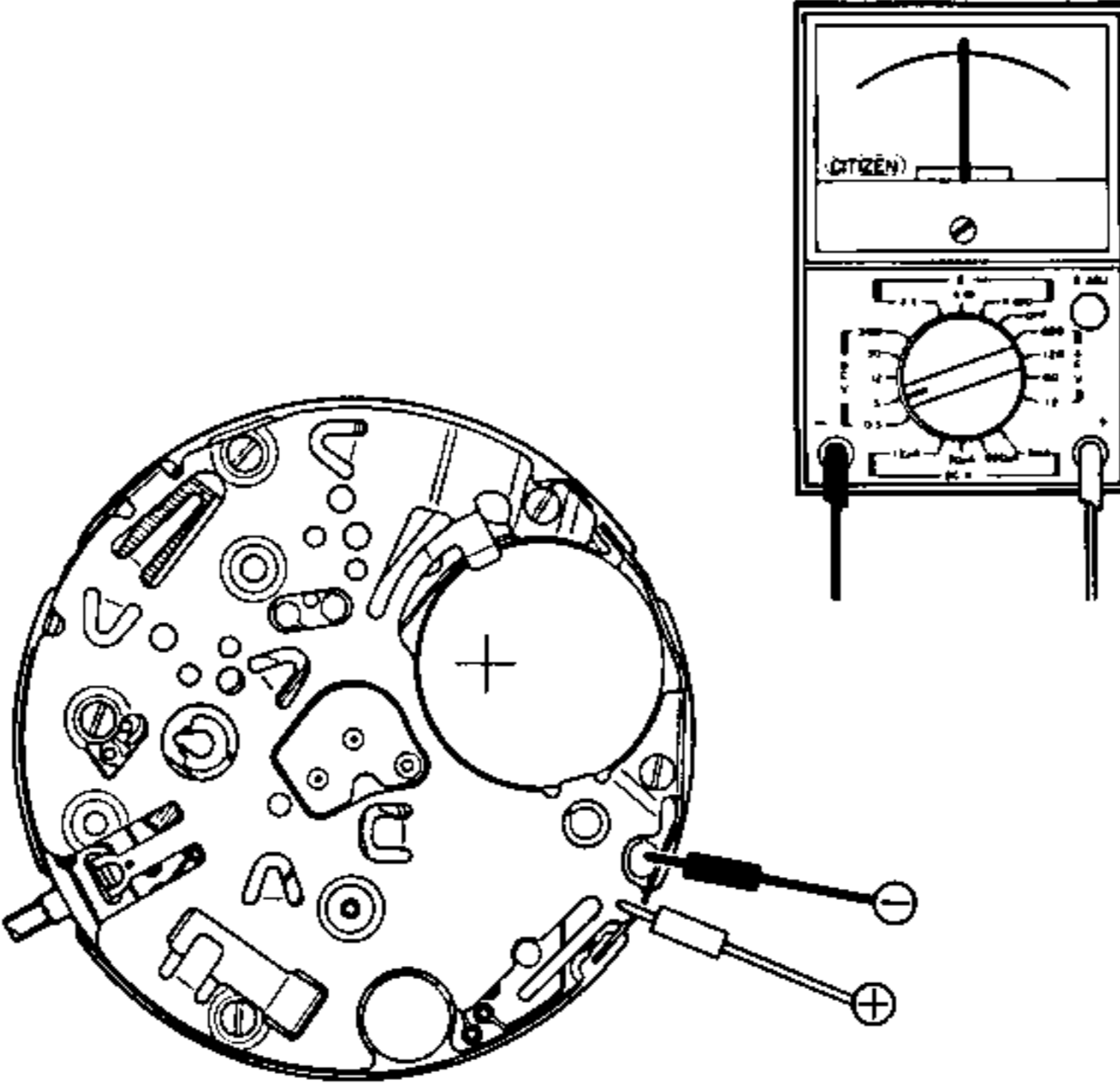

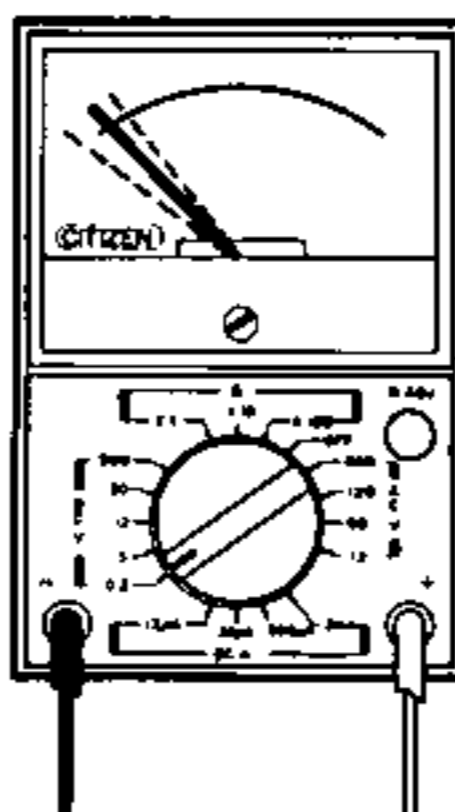
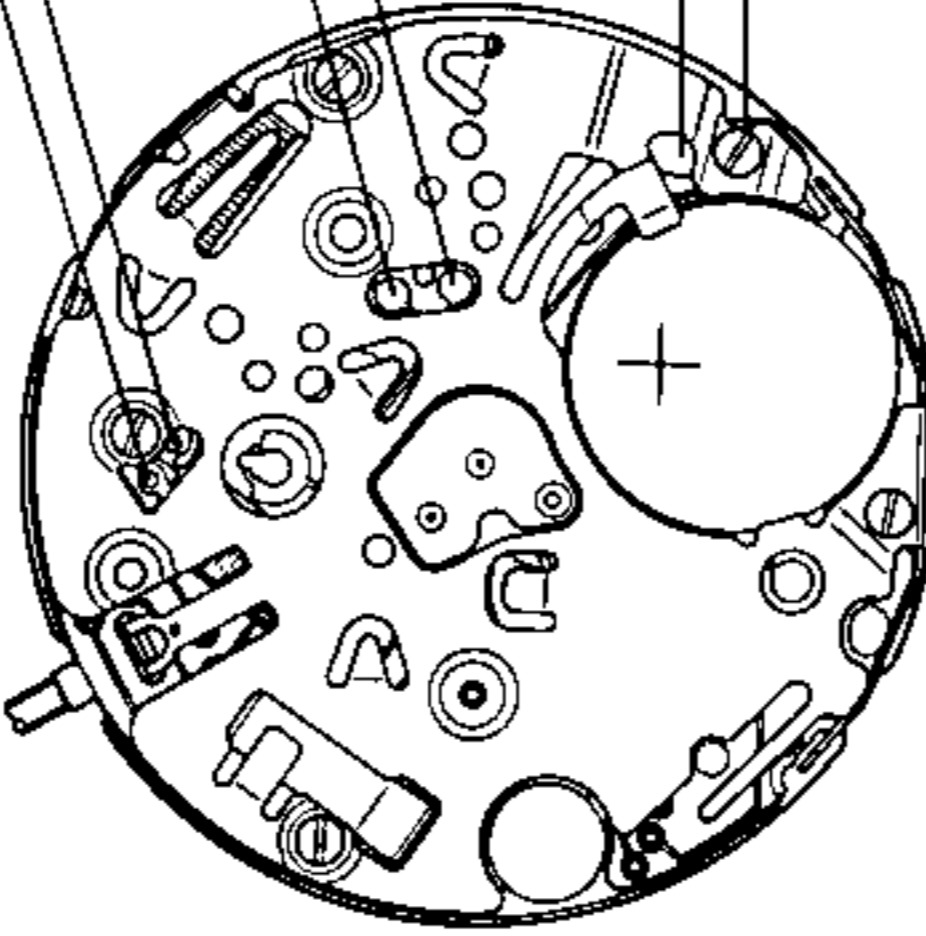
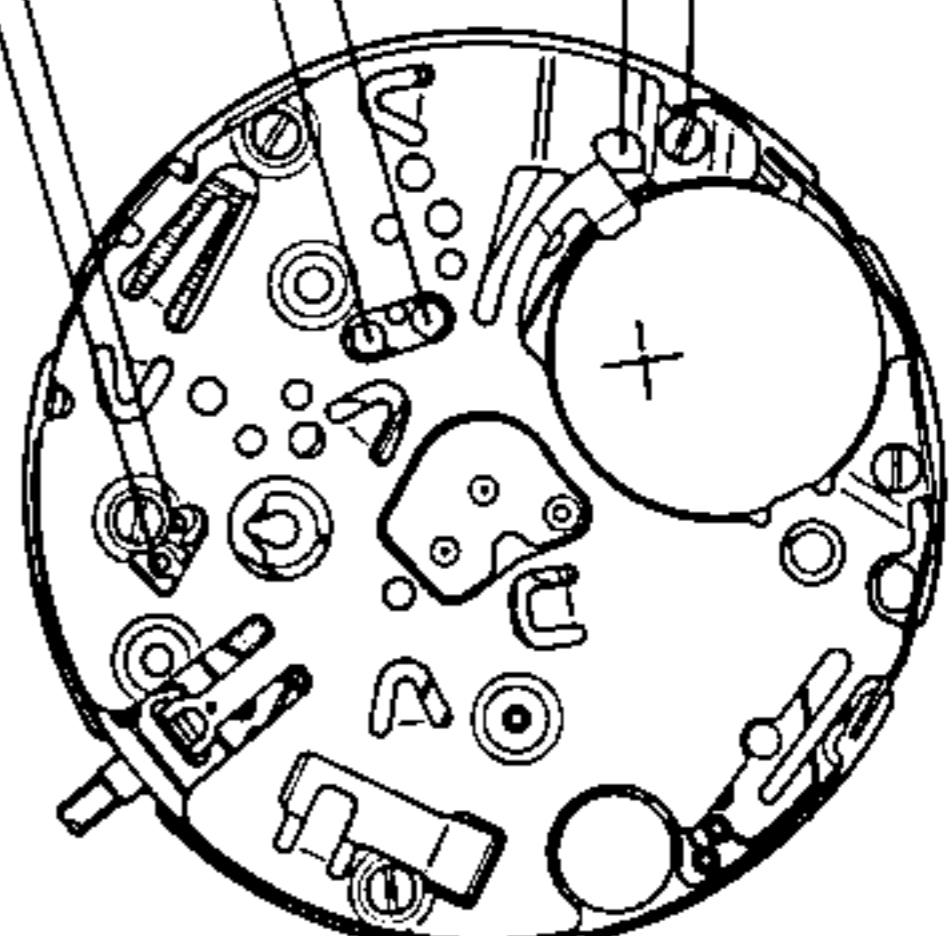

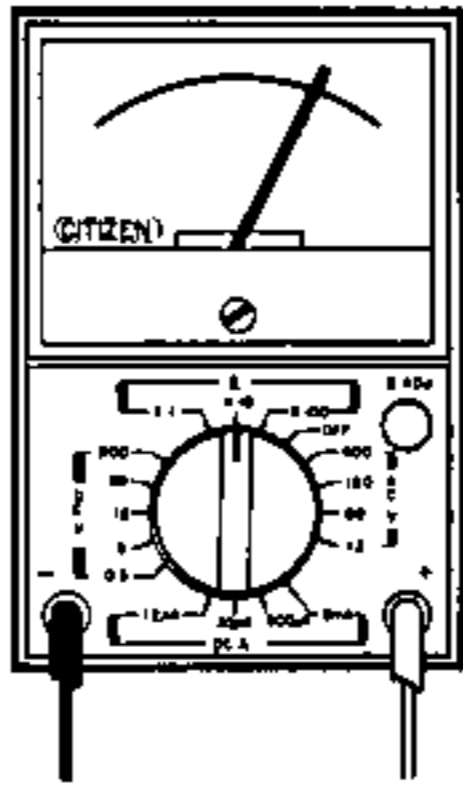
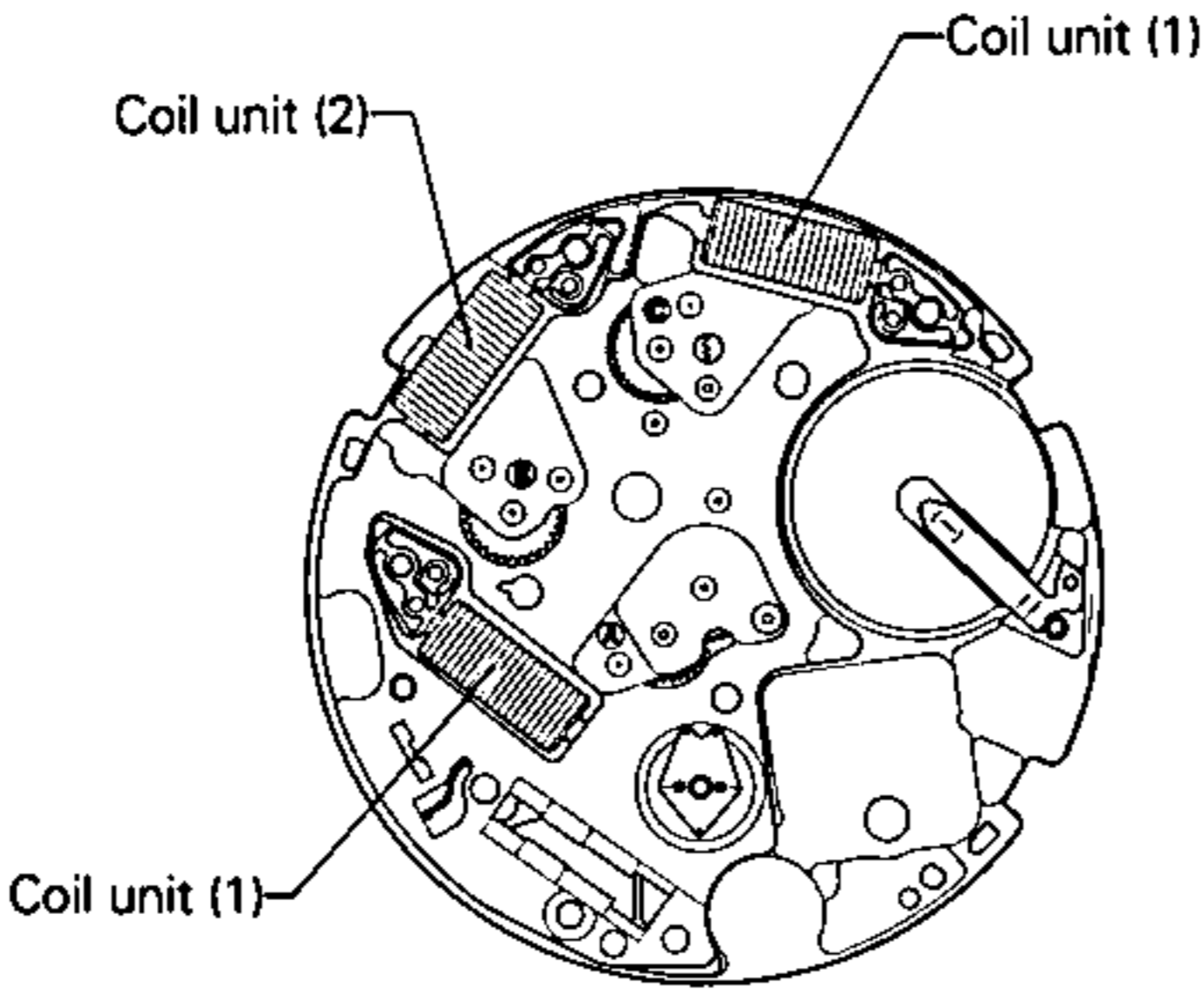

Check item	Method	Results and procedure
<p>① Measurement of power cell voltage</p> <p>Perform the same procedure for 6800 and 6850.</p>	<p>* Refer to Technical Manual, Basic Course II-1-a for the setting procedure of the tester.</p> <p>&lt;Tester range: DC 3V&gt;</p> 	<ul style="list-style-type: none"> <li>● Over 1.5 V → OK</li> <li>● Under 1.5 V → OK</li> </ul>
<p>② Check of output signal</p> <p>*Set watch to zero position confirmation mode.</p> <p>Perform the same procedure for 6800 and 6850.</p> <p>6800:</p>  <p>6850:</p> 	<p>* Refer to Technical Manual, Basic Course II-1-b for the setting procedure of the tester.</p> <p>&lt;Tester range: DC 0.3 V&gt;</p>  <p><b>(Measuring method)</b> With the lead bars applied, push the push button.</p> <div style="display: flex; justify-content: space-around;"> <div data-bbox="549 2041 1129 2797"> <p>A3: Second hand</p> <p>A2: Minute &amp; hour hands</p> <p>A1: Aux. Minute &amp; hour hands</p>  <p>CAL. 6800:</p> </div> <div data-bbox="1232 2041 1926 2797"> <p>A3: Second hand</p> <p>A2: Minute, hour &amp; 24-hour hands</p> <p>A1: Auxiliary hand</p>  <p>CAL. 6850:</p> </div> </div>	<ul style="list-style-type: none"> <li>● A1 output signal Tester pointer swings. → OK</li> <li>● A2 output signal Tester pointer swings. → OK</li> <li>● A3 output signal Tester pointer swings. → OK</li> </ul>

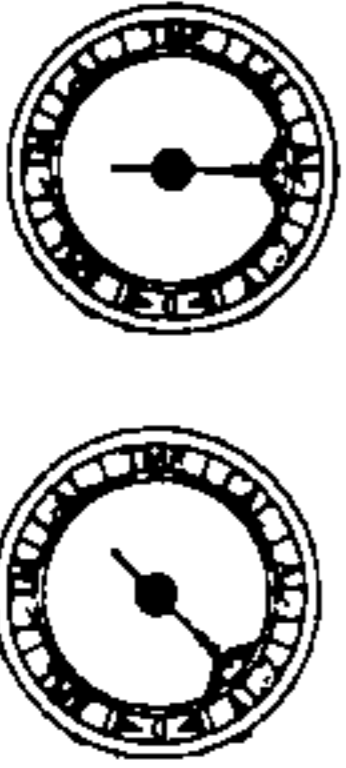

Check item	Method	Results and procedure
<p>③ Check of connection parts</p> <p>Perform the same procedure for 6800 and 6850.</p>	<p>*Refer to the analog part of Technical Manual, Basic Course II-2-a.</p> <p>If the output signal cannot be obtained for checking, dust may be caught between electronic circuit unit and each part.</p> <p>When the fixing screws of the electronic circuit unit are loosened, the output signal may not be obtained. Tighten those screws securely.</p>	<p>● Dust and dirt → Remove</p>
<p>④ Measurement of coil resistance</p> <p>Perform the same procedure for 6800 and 6850.</p>	<p>* Refer to Technical Manual, Basic Course II-1-c for the setting procedure of the tester.</p> <p style="text-align: center;">&lt;Tester range: x 10Ω&gt;</p>  	<p>Resistance</p> <ul style="list-style-type: none"> <li>● Coil unit (1) 2.1 kΩ ~ 2.5 kΩ → OK</li> <li>● Coil unit (2) 1.2 kΩ ~ 1.5 kΩ → OK</li> </ul>
<p>⑤ Check of train wheel</p> <p>Perform the same procedure for 6800 and 6850.</p>	<p>* Refer to Technical Manual, Basic Course II-2-b.</p> <ul style="list-style-type: none"> <li>● Confirm each part of the plastic gears are not be bent or broken.</li> </ul>	<ul style="list-style-type: none"> <li>● If the train wheel is normal, replace the electronic circuit unit.</li> </ul>
<p>⑥ Check of dial side</p> <p>Perform the same procedure for 6800 and 6850.</p>	<p>* Refer to Technical Manual, Basic Course II-2-c.</p> <ul style="list-style-type: none"> <li>● Each part of the plastic gears and pinions must not be bent or broken.</li> </ul>	

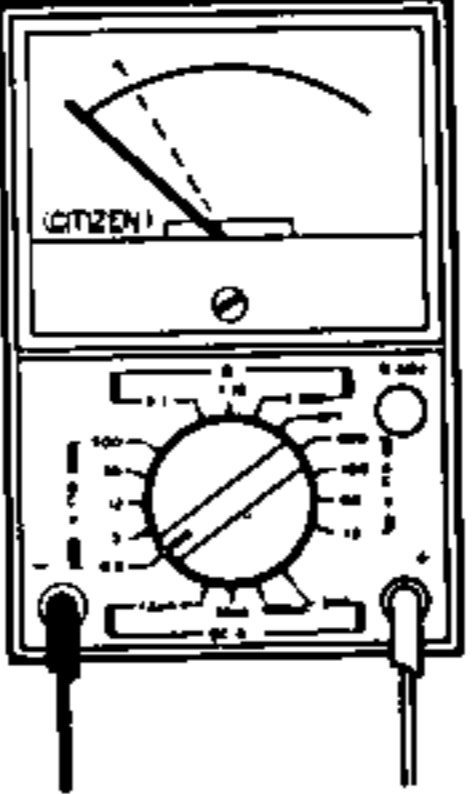
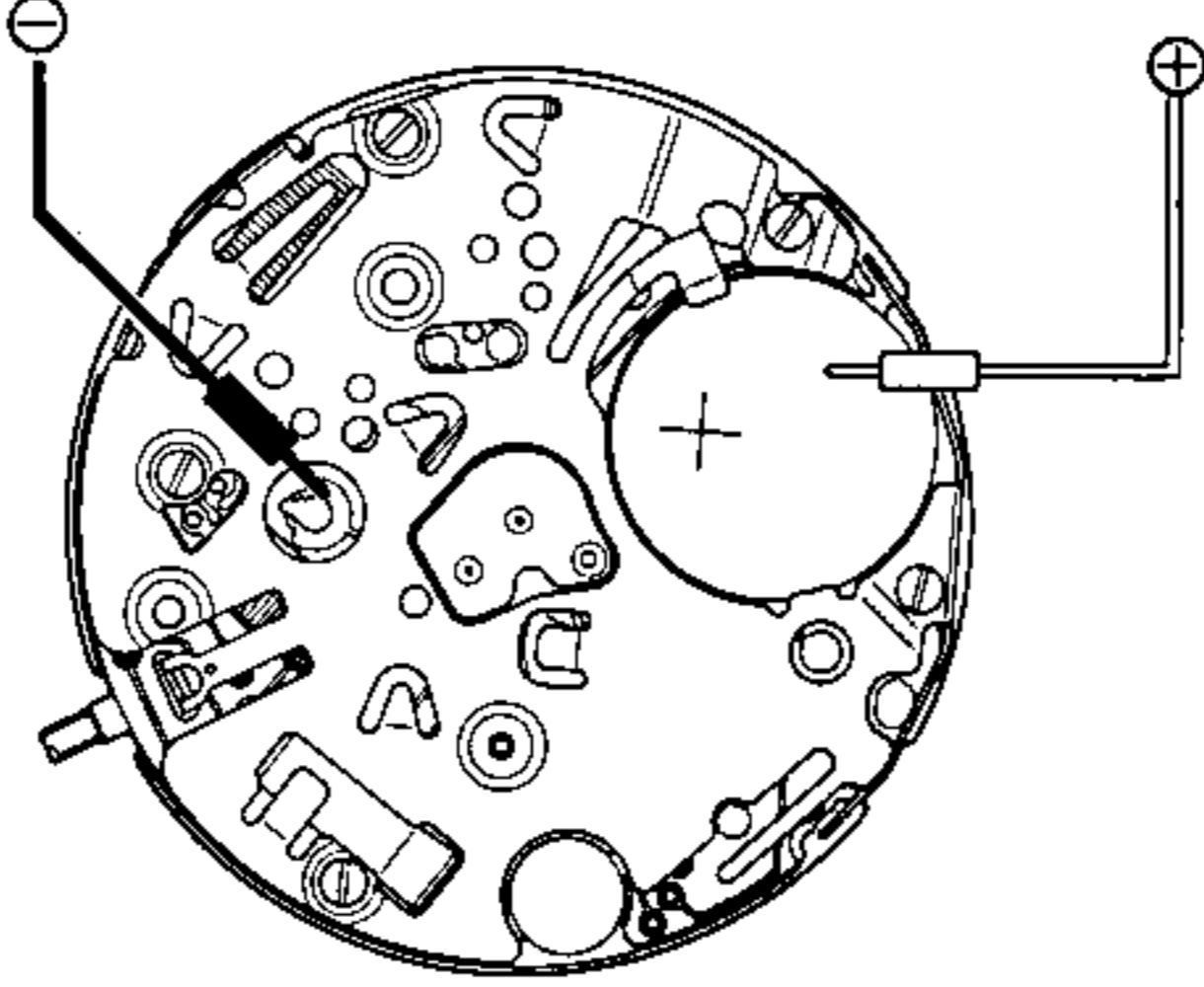

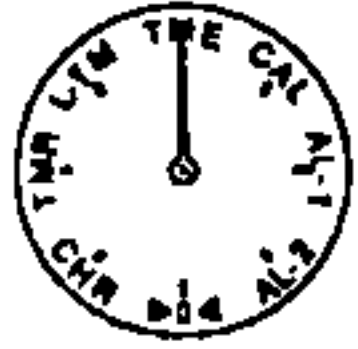
Check item	Method	Results and procedure
<p>⑦ Check of contacts of buzzer</p> <p>* Set the watch to either alarm 1 or 2 mode.</p> <p>Perform the same procedure for 6800 and 6850.</p> <p>6800:</p>  <p>6850:</p> 	<p>* Refer to Technical Manual, Basic Course II-1-c for the setting procedure of the tester</p> <p style="text-align: right;">&lt;Tester range: DC 3V&gt;</p>  <p><b>(Measuring method)</b> Set the watch to either alarm 1 or 2 mode and set the alarm monitor, then apply the ⊕ lead bar of the tester to the top of the battery and the ⊖ one to the buzzer contact spring.</p>  <ul style="list-style-type: none"> <li>● If the part of the piezo-electric element stuck directly to the case back to which the buzzer contact spring will touch is cracked or broken, the alarm does not sound normally.</li> <li>● Check the buzzer contact spring for deformation and fatigue.</li> </ul>	<ul style="list-style-type: none"> <li>● Tester pointer swings → OK</li> <li>● Tester pointer does not swing at all → Replace the electronic circuit unit.</li> </ul> <ul style="list-style-type: none"> <li>● The piezo-electric element is cracked or broken → Replace the case.</li> <li>● The buzzer contact spring is deformed or fatigued → Replace the buzzer contact spring.</li> </ul>

Check item	Method	Results and procedure
<p><b>8</b> Measurement of time rate</p> <p>* Set the watch to the time mode.</p> <p>Perform the same procedure for 6800 and 6850.</p> <p>6800:</p>  <p>6850:</p> 	<p>* Refer to Technical Manual, Basic Course II-2-d.</p> <p>Measure the time with CITIZEN QUARTZ TESTER.</p> <ul style="list-style-type: none"> <li>● Measurement of time rate The time can be measured with the tester in any range.</li> </ul> <p>Do not measure the time rate under the direct sunlight or incandescent lamp. If measured under them, the time rate may shift and may not be measured correctly.</p>	
<p><b>9</b> Check of using condition</p> <p>Perform the same procedure for 6800 and 6850.</p>	<p>* Refer to Technical Manual, Basic Course II-2-e.</p> <ul style="list-style-type: none"> <li>● Since the accuracy may be affected by the environment of the watch, confirm the using condition of the watch (Magnetism, extremely high or low temperature and humidity, impacts, etc).</li> <li>● Confirm how many days have passed after the time was set last time.</li> </ul>	

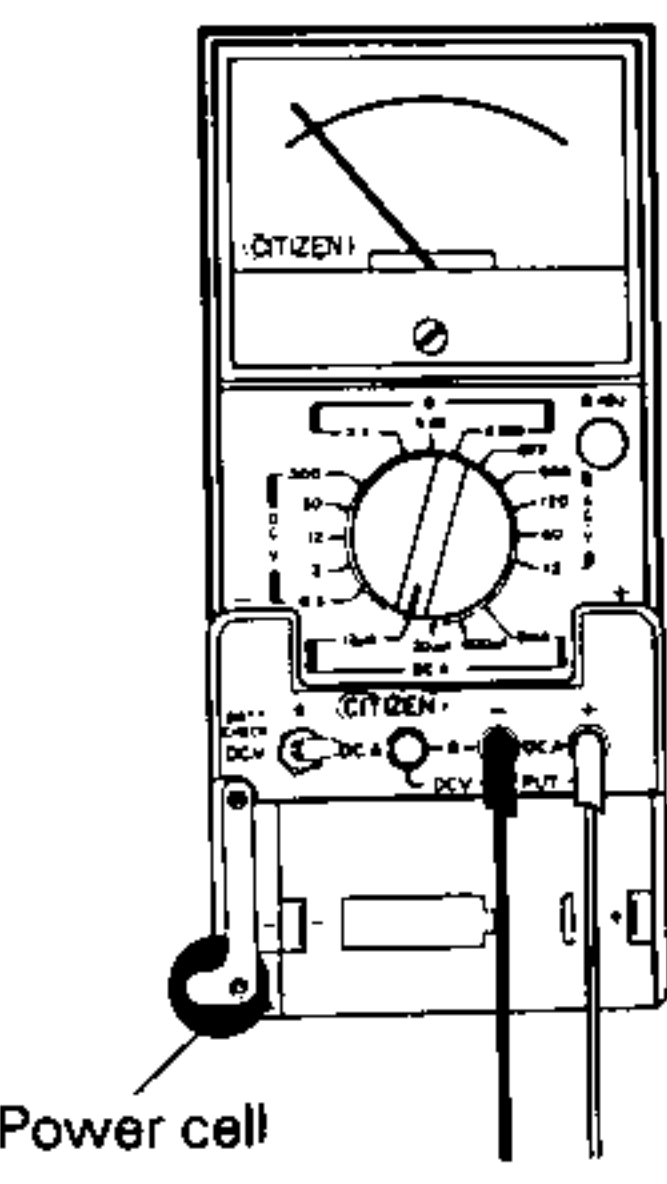
Check item	Method	Results and procedure
<p>⑩ Measurement of current consumption</p> <p><b>(Measuring method)</b> Refer to the measurement of current consumption in <b>Battery replacement procedure I.</b></p> <p>Perform the same procedure for 6800 and 6850.</p>	<p>* Refer to Technical Manual, Basic Course II-1-f for the setting procedure of the tester.</p> <p style="text-align: center;">&lt;Tester range: DC 12<math>\mu</math>A&gt;</p> <div style="text-align: center;">  <p>Power cell</p> </div> <p>* If there is any dirt or dust on any connecting part of the train wheel or circuit, the current consumption may be increased.</p>	<ul style="list-style-type: none"> <li>● <b>Under 2.0 <math>\mu</math>A</b> → OK</li> <li>● <b>Over 2.0 <math>\mu</math>A</b> → Replace the electronic circuit unit.</li> </ul>
<p>⑪ Check of appearance and functions</p> <p>Perform the same procedure for 6800 and 6850.</p>	<p>* Refer to Technical Manual, Basic Course II-2-f.</p> <ul style="list-style-type: none"> <li>● Confirm there is not duct, dirt, etc. on the dial.</li> <li>● Confirm each push button works securely.</li> </ul>	

**CITIZEN WATCH CO., LTD.**  
Tokyo, Japan